

Transistors

USP5172

AMPLIFIER TRANSISTOR

- Collector-Emitter Voltage: $V_{CE0} = 25V$
- Collector Dissipation: $P_C (\text{max}) = 625mW$

ABSOLUTE MAXIMUM RATINGS ($T_a = 25^\circ C$)

Characteristic	Symbol	Rating	Unit
Collector-Base Voltage	V_{CBO}	25	V
Collector-Emitter Voltage	V_{CEO}	25	V
Emitter-Base Voltage	V_{EBO}	5	V
Collector Current	I_C	100	mA
Collector Dissipation	P_C	625	mW
Junction Temperature	T_J	150	$^\circ C$
Storage Temperature	T_{stg}	-55 ~ 150	$^\circ C$

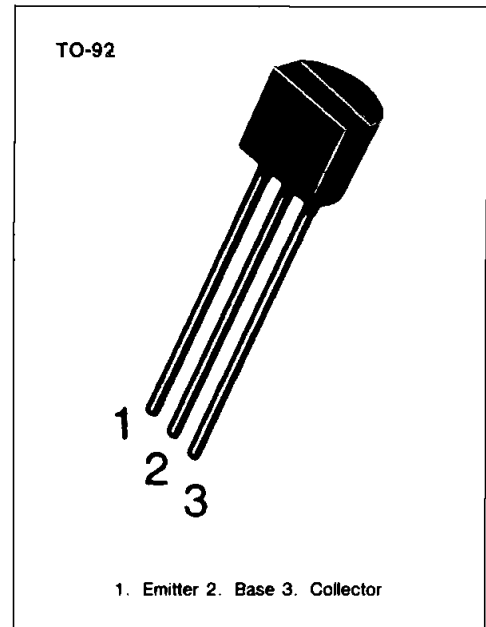

ELECTRICAL CHARACTERISTICS ($T_a = 25^\circ C$)

Characteristic	Symbol	Test Conditions	Min	Typ	Max	Unit
Collector-Emitter Breakdown Voltage	BV_{CEO}	$I_C = 10mA, I_B = 0$	25			V
Collector Cut-off Current	I_{CBO}	$V_{CB} = 25V, I_E = 0$			100	nA
Collector Cut-off Current	I_{CES}	$V_{CE} = 25V, V_{BE} = 0$			100	nA
Emitter Cut-off Current	I_{EBO}	$V_{BE} = 5V, I_C = 0$			100	nA
*DC Current Gain	h_{FE}	$I_C = 10mA, V_{CE} = 10V$	100		500	
Collector-Emitter Saturation Voltage	$V_{CE} (\text{sat})$	$I_C = 10mA, I_B = 1mA$			0.25	V
Base-Emitter Saturation Voltage	$V_{BE} (\text{sat})$	$I_C = 10mA, I_B = 1mA$		0.75		V
Current Gain Bandwidth Product	f_T	$I_C = 2mA, V_{CE} = 5V$		120		MHz
Base Emitter On Voltage	$V_{BE} (\text{on})$	$I_C = 10mA, V_{CE} = 10V$	0.5		1.2	V

* Pulse Test: Pulse Width = 300 μ s, Duty Cycle = 2%

DC CURRENT GAIN

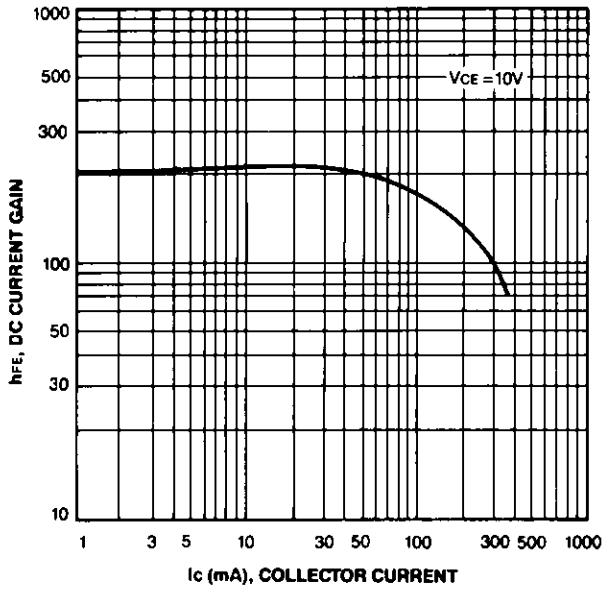

CURRENT GAIN-BANDWIDTH

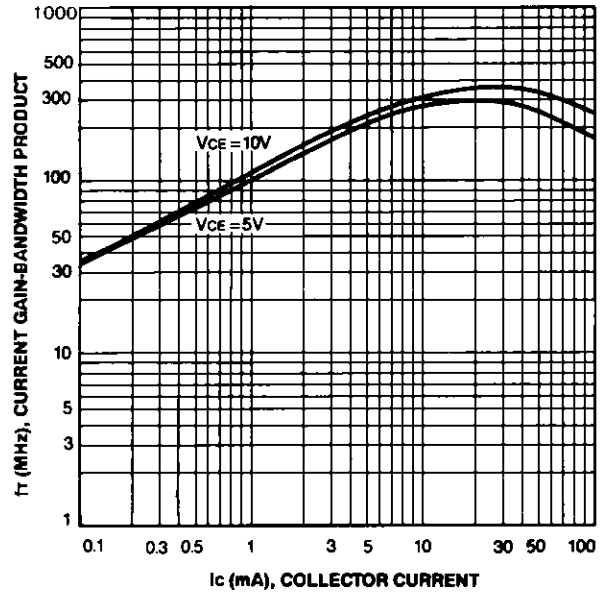

**COLLECTOR-EMITTER SATURATION VOLTAGE
BASE-EMITTER SATURATION VOLTAGE**

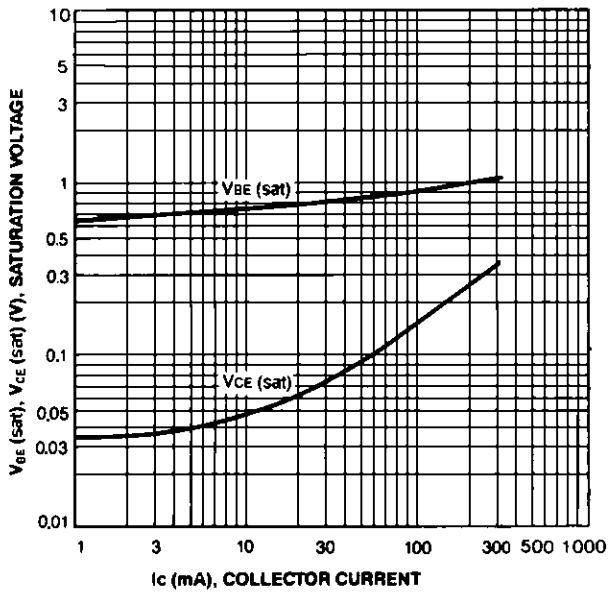

OUTPUT CAPACITANCE

