



FEATURES

- Access time : 70/100ns(max)
- CMOS Low operating power
  - Operating : 30/20mA (Icc max)
  - Standby : 20µA (TYP.) L-version
  - 2µA (TYP.) LL-version
- Single 2.3V~2.7V power supply
- Operating Temperature:
  - Commercial : 0°C~70°C
  - Extended : -20°C~80°C
- All inputs and outputs TTL compatible
- Fully static operation
- Three state outputs
- Data retention voltage : 1.5V (min)
- Package : 32-pin 8mm×20mm TSOP-I
- 32-pin 8mm×13.4mm STSOP

GENERAL DESCRIPTION

The UT62V5128 is a 4,194,304-bit high speed CMOS static random access memory organized as 524,288 words by 8 bits. It is fabricated using high performance, high reliability CMOS technology.

The UT62V5128 is designed for high speed system applications. It is particularly well suited for battery back-up nonvolatile memory applications.

The UT62V5128 operates from a single 2.3V~2.7V power supply and all inputs and outputs are fully TTL compatible.

PIN CONFIGURATION

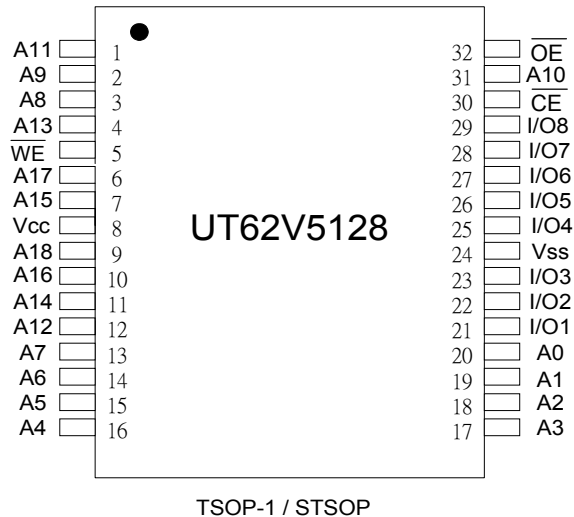

FUNCTIONAL BLOCK DIAGRAM

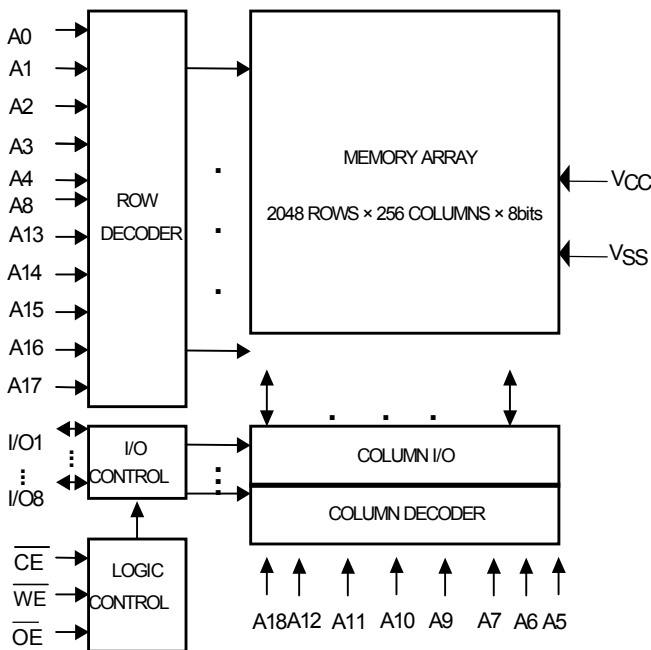

PIN DESCRIPTION

SYMBOL	DESCRIPTION
A0 - A18	Address Inputs
I/O1 - I/O8	Data Inputs/Outputs
$\overline{CE}$	Chip Enable Input
$\overline{WE}$	Write Enable Input
$\overline{OE}$	Output Enable Input
Vcc	Power Supply
Vss	Ground
NC	No Connection



## TRUTH TABLE

MODE	$\overline{WE}$	$\overline{CE}$	$\overline{OE}$	I/O OPERATION	SUPPLY CURRENT
Standby	X	H	X	High – Z	$I_{SB}, I_{SB1}$
Output Disable	H	L	H	High – Z	$I_{CC}$
Read	H	L	L	$D_{OUT}$	$I_{CC}$
Write	L	L	X	$D_{IN}$	$I_{CC}$

Note: H =  $V_{IH}$ , L =  $V_{IL}$ , X = Don't care.

## ABSOLUTE MAXIMUM RATINGS\*

PARAMETER	SYMBOL	RATING	UNIT
Terminal Voltage with Respect to $V_{SS}$	$V_{TERM}$	-0.5 to 3.6	V
Operating Temperature	Commercial	0 to 70	$^{\circ}C$
	Extended	-20 to 80	$^{\circ}C$
Storage Temperature	$T_{STG}$	-65 to 150	$^{\circ}C$
Power Dissipation	$P_D$	1	W
DC Output Current	$I_{OUT}$	50	mA
Soldering Temperature (under 10 secs)	$T_{solder}$	260	$^{\circ}C$

\*Stresses greater than those listed under "Absolute Maximum Ratings" may cause permanent damage to the device. This is a stress rating only and functional operation of the device or any other conditions above those indicated in the operational sections of this specification is not implied. Exposure to the absolute maximum rating conditions for extended period may affect device reliability.

DC ELECTRICAL CHARACTERISTICS ( $V_{CC} = 2.3V \sim 2.7V$ ,  $T_A = 0^{\circ}C$  to  $70^{\circ}C$  /  $-20^{\circ}C$  to  $80^{\circ}C$  (E))

PARAMETER	SYMBOL	TEST CONDITION	MIN.	TYP.	MAX.	UNIT
Power Voltage	$V_{CC}$		2.3	2.5	2.7	V
Input High Voltage	$V_{IH}$		2.0	-	$V_{CC}+0.3$	V
Input Low Voltage	$V_{IL}$		-0.2	-	0.6	V
Input Leakage Current	$I_{LI}$	$V_{SS} \leq V_{IN} \leq V_{CC}$	-1	-	1	$\mu A$
Output Leakage Current	$I_{LO}$	$V_{SS} \leq V_{IO} \leq V_{CC}$ , Output Disabled	-1	-	1	$\mu A$
Output High Voltage	$V_{OH}$	$I_{OH} = -0.5mA$	2.0	-	-	V
Output Low Voltage	$V_{OL}$	$I_{OL} = 0.5mA$	-	-	0.4	V
Operating Power Supply Current	$I_{CC}$	Cycle time=Min.100% duty, $\overline{CE} = V_{IL}, I_{IO} = 0mA$ ,	70	20	30	mA
			100	15	20	mA
	$I_{CC1}$	Cycle time = $1\mu s$ , 100% duty, $\overline{CE} \leq 0.2, I_{IO} = 0mA$ , other pins at 0.2V or $V_{CC}-0.2V$ ,	-	3	4	mA
	$I_{CC2}$	Cycle time = 500ns, 100% duty, $\overline{CE} \leq 0.2, I_{IO} = 0mA$ other pins at 0.2V or $V_{CC}-0.2V$ ,	-	6	8	mA
Standby Current(TTL)	$I_{SB1}$	$\overline{CE} = V_{IH}$	-	0.3	0.5	mA
Standby Current(CMOS)	$I_{SB1}$	$\overline{CE} \geq V_{CC}-0.2V$	-L	20	80	$\mu A$
		other pins at 0.2V or $V_{CC}-0.2V$ ,	-LL	2	15	$\mu A$

**CAPACITANCE** (TA=25°C, f=1.0MHz)

PARAMETER	SYMBOL	MIN.	MAX	UNIT
Input Capacitance	C <sub>IN</sub>	-	6	pF
Input/Output Capacitance	C <sub>I/O</sub>	-	8	pF

Note : These parameters are guaranteed by device characterization, but not production tested.

**AC TEST CONDITIONS**

Input Pulse Levels	0V to 2.2V
Input Rise and Fall Times	5ns
Input and Output Timing Reference Levels	1.5V
Output Load	C <sub>L</sub> = 30pF, I <sub>OH</sub> /I <sub>OL</sub> = -0.5mA/0.5mA

**AC ELECTRICAL CHARACTERISTICS** (V<sub>CC</sub> = 2.3V~2.7V, TA = 0°C to 70°C / -20°C to 80°C(E))**(1) READ CYCLE**

PARAMETER	SYMBOL	UT62V5128-70		UT62V5128-100		UNIT
		MIN.	MAX.	MIN.	MAX.	
Read Cycle Time	t <sub>RC</sub>	70	-	100	-	ns
Address Access Time	t <sub>AA</sub>	-	70	-	100	ns
Chip Enable Access Time	t <sub>ACE</sub>	-	70	-	100	ns
Output Enable Access Time	t <sub>OE</sub>	-	35	-	50	ns
Chip Enable to Output in Low Z	t <sub>CLZ*</sub>	10	-	10	-	ns
Output Enable to Output in Low Z	t <sub>OLZ*</sub>	5	-	5	-	ns
Chip Disable to Output in High Z	t <sub>CHZ*</sub>	-	25	-	30	ns
Output Disable to Output in High Z	t <sub>OHZ*</sub>	-	25	-	35	ns
Output Hold from Address Change	t <sub>OH</sub>	5	-	5	-	ns

**(2) WRITE CYCLE**

PARAMETER	SYMBOL	UT62V5128-70		UT62V5128-100		UNIT
		MIN.	MAX.	MIN.	MAX.	
Write Cycle Time	t <sub>WC</sub>	70	-	100	-	ns
Address Valid to End of Write	t <sub>AW</sub>	60	-	80	-	ns
Chip Enable to End of Write	t <sub>CW</sub>	60	-	80	-	ns
Address Set-up Time	t <sub>AS</sub>	0	-	0	-	ns
Write Pulse Width	t <sub>WP</sub>	55	-	70	-	ns
Write Recovery Time	t <sub>WR</sub>	0	-	0	-	ns
Data to Write Time Overlap	t <sub>DW</sub>	30	-	40	-	ns
Data Hold from End of Write Time	t <sub>DH</sub>	0	-	0	-	ns
Output Active from End of Write	t <sub>OW*</sub>	5	-	5	-	ns
Write to Output in High Z	t <sub>WHZ*</sub>	-	30	-	40	ns

\*These parameters are guaranteed by device characterization, but not production tested.



TIMING WAVEFORMS

READ CYCLE 1 (Address Controlled) (1,2,4)

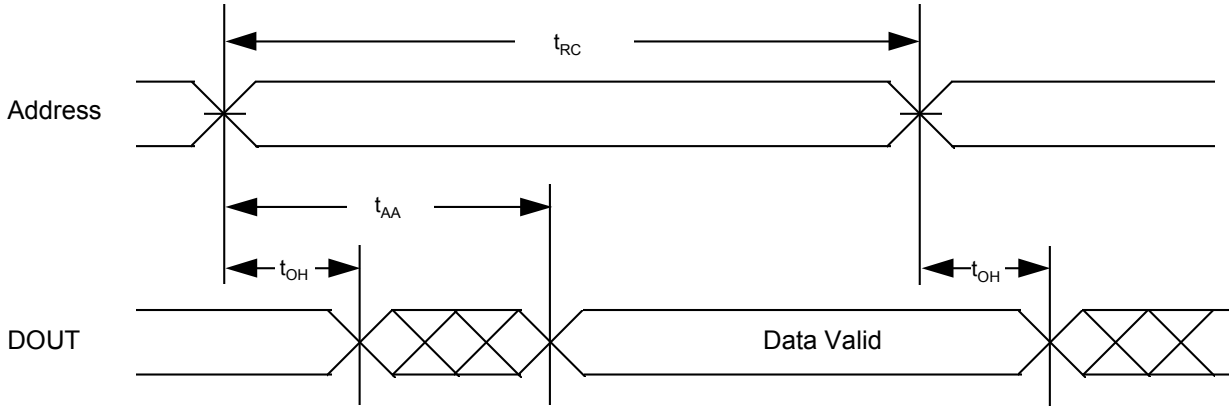

READ CYCLE 2 ( $\overline{CE}$  and  $\overline{OE}$  Controlled) (1,3,5,6)

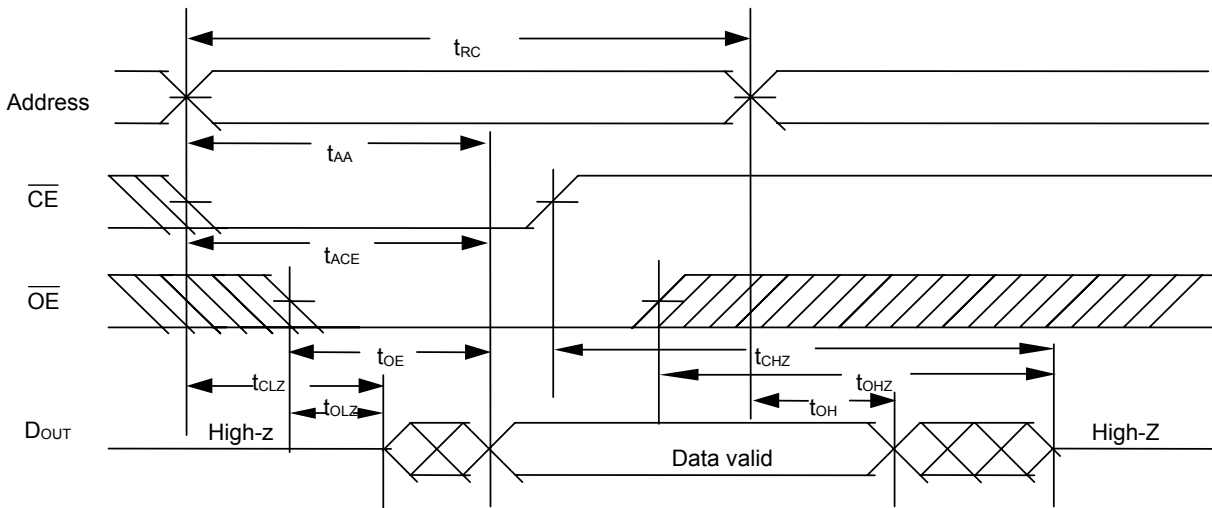

Notes :

1.  $\overline{WE}$  is HIGH for read cycle.
2. Device is continuously selected  $\overline{CE} = V_{IL}$ .
3. Address must be valid prior to or coincident with  $\overline{CE}$  transition; otherwise  $t_{AA}$  is the limiting parameter.
4.  $\overline{OE}$  is LOW.
5.  $t_{CLZ}$ ,  $t_{OLZ}$ ,  $t_{CHZ}$  and  $t_{OHZ}$  are specified with  $C_L = 5pF$ . Transition is measured  $\pm 500mV$  from steady state.
6. At any given temperature and voltage condition,  $t_{CHZ}$  is less than  $t_{CLZ}$ ,  $t_{OHZ}$  is less than  $t_{OLZ}$ .



**WRITE CYCLE 1** ( $\overline{WE}$  Controlled) (1,2,3,5)

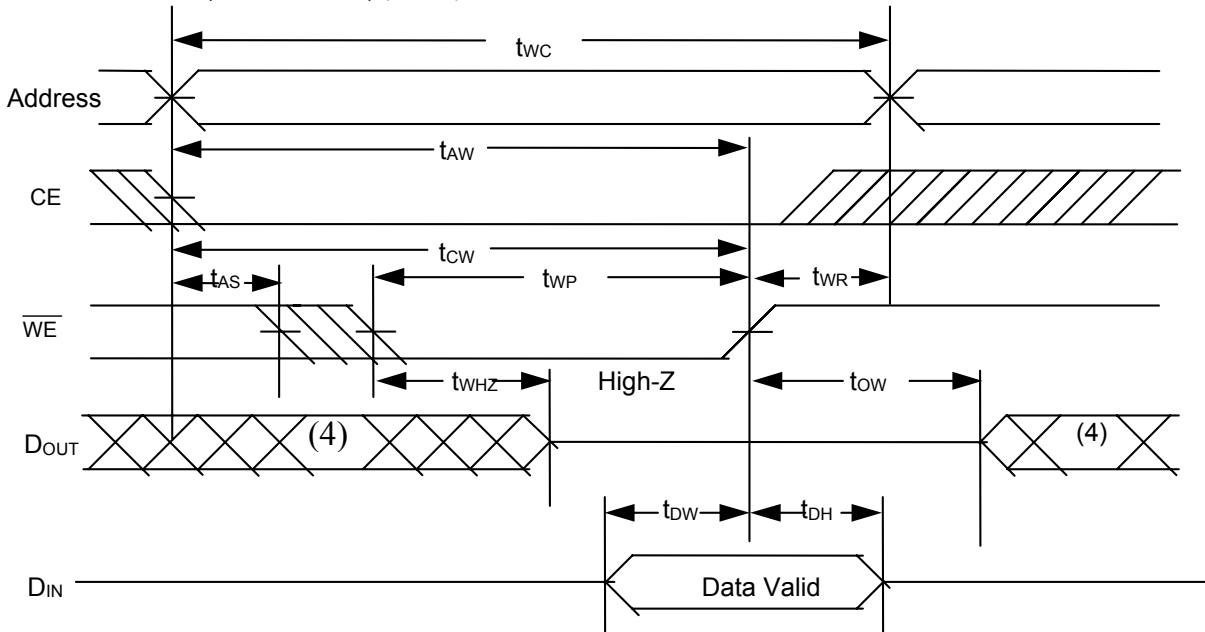

**WRITE CYCLE 2** ( $\overline{CE}$  Controlled) (1,2,5)

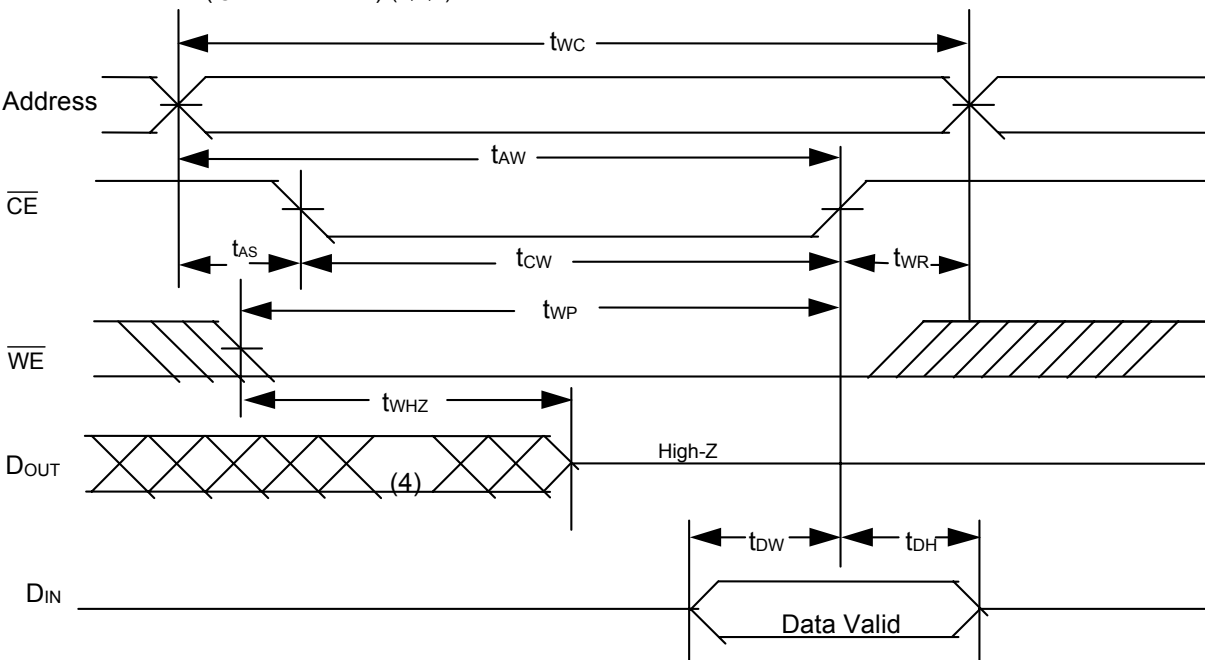

Notes :

1.  $\overline{WE}$  or  $\overline{CE}$  must be HIGH during all address transitions.
2. A write occurs during the overlap of a low  $\overline{CE}$  and a low  $\overline{WE}$ .
3. During a  $\overline{WE}$  controlled write cycle with  $\overline{OE}$  LOW,  $t_{WP}$  must be greater than  $t_{WHZ} + t_{DW}$  to allow the drivers to turn off and data to be placed on the bus.
4. During this period, I/O pins are in the output state, and input signals must not be applied.
5. If the  $\overline{CE}$  LOW transition occurs simultaneously with or after  $\overline{WE}$  LOW transition, the outputs remain in a high impedance state.
6.  $t_{OW}$  and  $t_{WHZ}$  are specified with  $C_L = 5pF$ . Transition is measured  $\pm 500mV$  from steady state.



**DATA RETENTION CHARACTERISTICS** (TA = 0°C to 70°C / -20°C to 80°C(E))

PARAMETER	SYMBOL	TEST CONDITION	MIN.	TYP.	MAX.	UNIT	
V <sub>CC</sub> for Data Retention	V <sub>DR</sub>	$\overline{CE} \geq V_{CC}-0.2V$	1.5	-	-	V	
Data Retention Current	I <sub>DR</sub>	V <sub>CC</sub> =1.5V $\overline{CE} \geq V_{CC}-0.2V$	- L	-	1	50	μA
			- LL	-	0.5	15	μA
Chip Disable to Data Retention Time	t <sub>CDR</sub>	See Data Retention Waveforms (below)	0	-	-	ms	
Recovery Time	t <sub>R</sub>		5	-	-	ms	

**DATA RETENTION WAVEFORM**

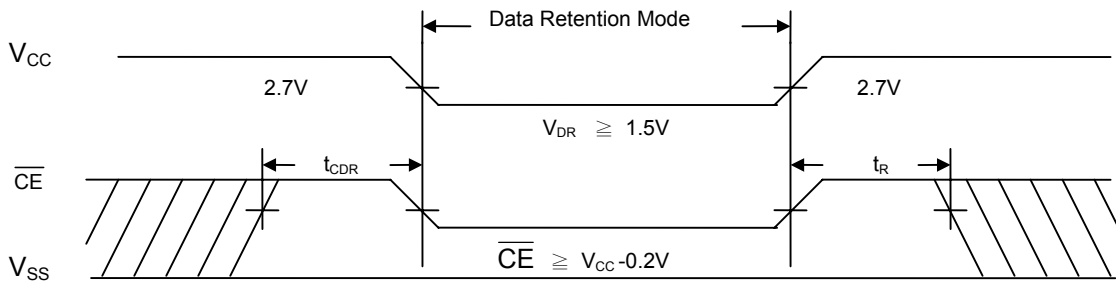



PACKAGE OUTLINE DIMENSION

32 pin 8mm x 20mm TSOP-I PACKAGE OUTLINE DIMENSION

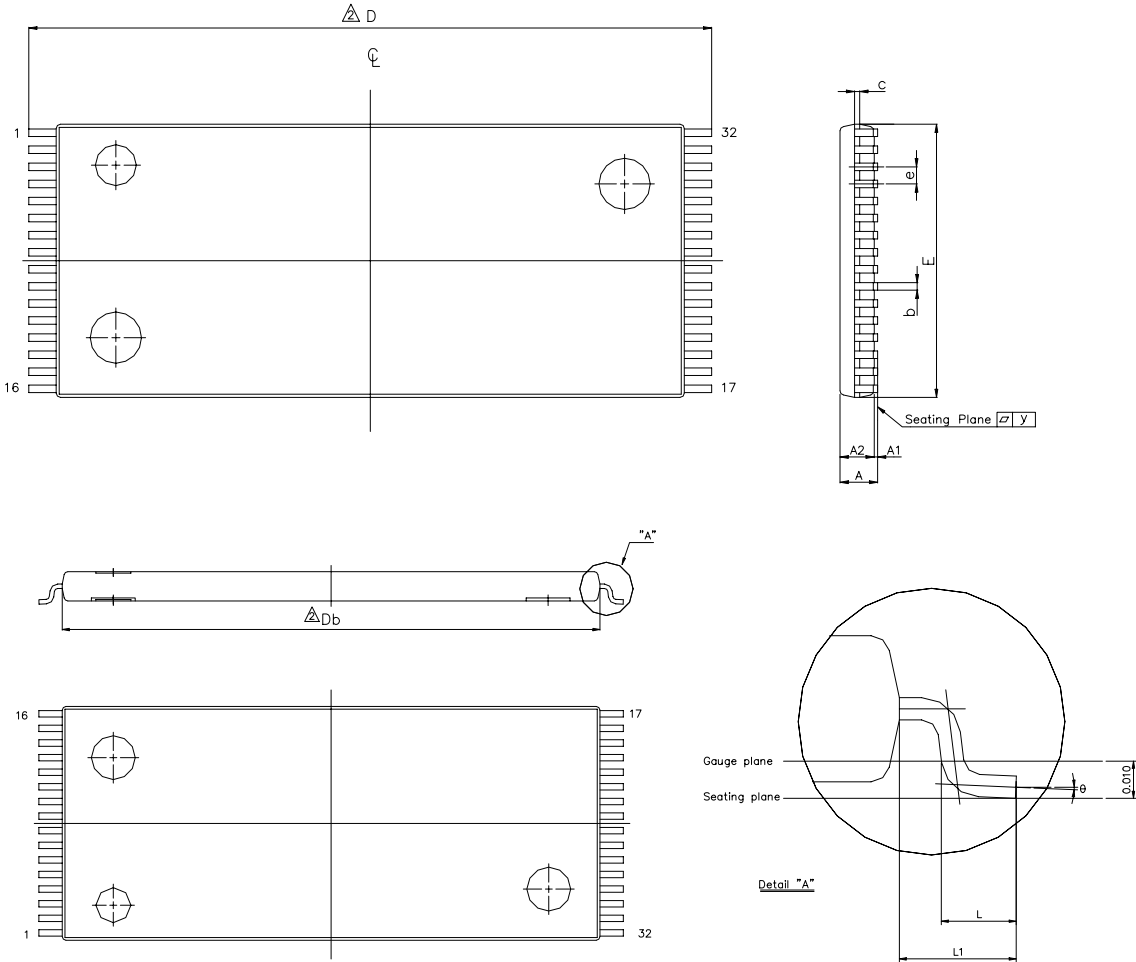

SYMBOL	UNIT	INCH(BASE)	MM(REF)
A		0.047 (MAX)	1.20 (MAX)
A1		0.004 ±0.002	0.10 ±0.05
A2		0.039 ±0.002	1.00 ±0.05
b		0.008 + 0.002	0.20 + 0.05
c		0.005 (TYP)	0.127 (TYP)
D		0.724 ±0.004	18.40 ±0.10
E		0.315 ±0.004	8.00 ±0.10
e		0.020 (TYP)	0.50 (TYP)
HD		0.787 ±0.008	20.00 ±0.20
L		0.0197 ±0.004	0.50 ±0.10
L1		0.0315 ±0.004	0.08 ±0.10
y		0.003 (MAX)	0.076 (MAX)
θ		0°~5°	0°~5°

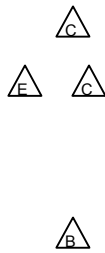







Rev. 1.0

UTRON

UT62V5128

512K X 8 BIT LOW POWER CMOS SRAM

## ORDERING INFORMATION

### COMMERCIAL TEMPERATURE

PART NO.	ACCESS TIME (ns)	STANDBY CURRENT ( $\mu$ A) TYP.	PACKAGE
UT62V5128LC-70L	70	20	32 PIN TSOP- I
UT62V5128LC-70LL	70	2	32 PIN TSOP- I
UT62V5128LC-100L	100	20	32 PIN TSOP- I
UT62V5128LC-100LL	100	2	32 PIN TSOP- I
UT62V5128LS-70L	70	20	36 PIN STSOP
UT62V5128LS-70LL	70	2	36 PIN STSOP
UT62V5128LS-100L	100	20	36 PIN STSOP
UT62V5128LS-100LL	100	2	36 PIN STSOP

### EXTENDED TEMPERATURE

PART NO.	ACCESS TIME (ns)	STANDBY CURRENT ( $\mu$ A) TYP.	PACKAGE
UT62V5128LC-70LE	70	20	32 PIN TSOP- I
UT62V5128LC-70LLE	70	2	32 PIN TSOP- I
UT62V5128LC-100LE	100	20	32 PIN TSOP- I
UT62V5128LC-100LLE	100	2	32 PIN TSOP- I
UT62V5128LS-70LE	70	20	36 PIN STSOP
UT62V5128LS-70LLE	70	2	36 PIN STSOP
UT62V5128LS-100LE	100	20	36 PIN STSOP
UT62V5128LS-100LLE	100	2	36 PIN STSOP



Rev. 1.0

UTRON

UT62V5128  
512K X 8 BIT LOW POWER CMOS SRAM

---

**REVISION HISTORY**

REVISION	DESCRIPTION	DATE
Preliminary Rev. 0.1	Original.	Mar, 2001
Rev. 1.0	1. The symbols CE# and OE# and WE# are revised as $\overline{CE}$ and $\overline{OE}$ and $\overline{WE}$ . 2. Separate Industrial and Consumer SPEC.	Jul 31,2001