

## HIGH SIDE SMART POWER SOLID STATE RELAY

**TARGET DATA**

TYPE	V <sub>DSS</sub>	R <sub>DS(on)</sub>	I <sub>OUT</sub>	V <sub>CC</sub>
VN05HSP	45 V	0.18 Ω	12 A	36 V

- OUTPUT CURRENT (CONTINUOUS):  
6A @ T<sub>c</sub>=25°C
- 5V LOGIC LEVEL COMPATIBLE INPUT
- THERMAL SHUT-DOWN
- UNDER VOLTAGE SHUT-DOWN
- OPEN DRAIN DIAGNOSTIC OUTPUT
- VERY LOW STAND-BY POWER DISSIPATION

**DESCRIPTION**

The VN05HSP is a monolithic devices made using SGS-THOMSON Vertical Intelligent Power Technology, intended for driving resistive or inductive loads with one side grounded.

Built-in thermal shut-down protects the chip from over temperature and short circuit.

The input control is 5V logic level compatible.

The open drain diagnostic output indicates open circuit (no load) and over temperature status.

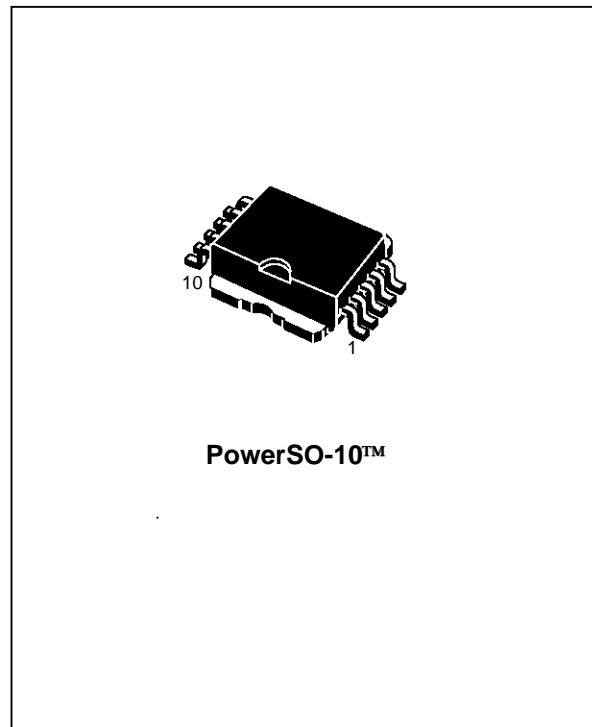

**BLOCK DIAGRAM**

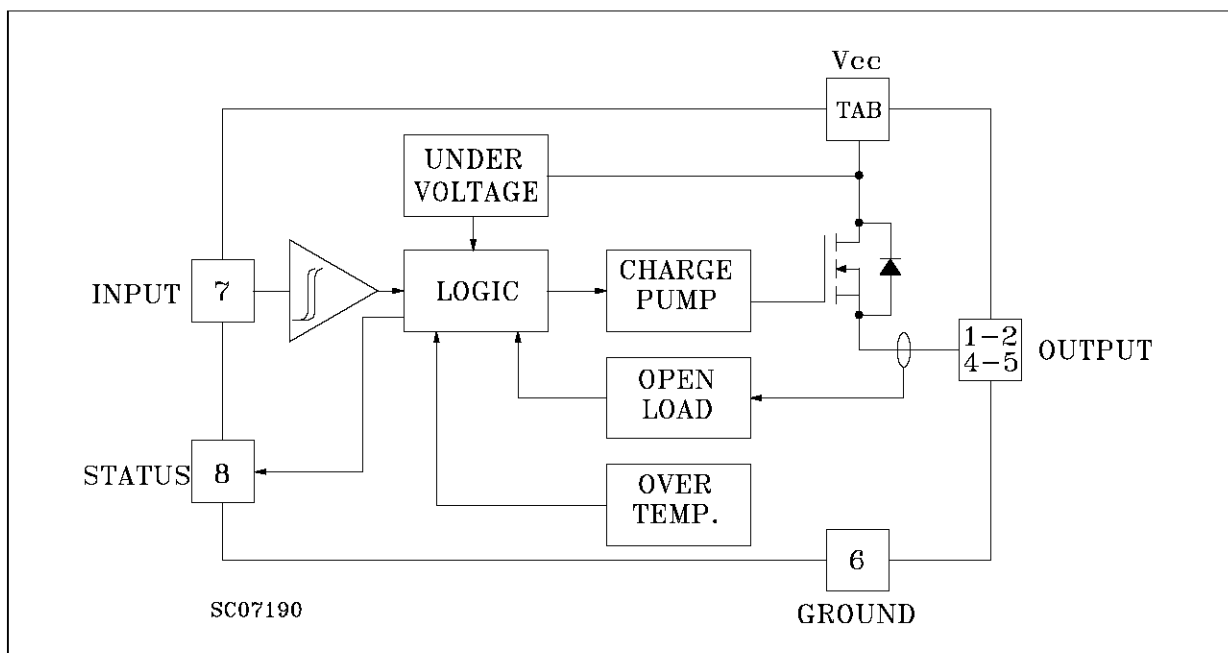

**ABSOLUTE MAXIMUM RATING**

Symbol	Parameter	Value	Unit
$V_{(BR)DSS}$	Drain-Source Breakdown Voltage	Internally Clamped	V
$I_{OUT}$	Output Current (cont.)	12	A
$I_R$	Reverse Output Current	-12	A
$I_{IN}$	Input Current	$\pm 10$	mA
$V_{CC}$	Supply Voltage (continuous)	40	V
$V_{CC}$	Supply Voltage (pulsed)	60	V
$-V_{CC}$	Reverse Supply Voltage	-4	V
$I_{STAT}$	Status Current	$\pm 10$	mA
$V_{ESD}$	Electrostatic Discharge (1.5 k $\Omega$ , 100 pF)	2000	V
$P_{tot}$	Power Dissipation at $T_c \leq 25^\circ C$	52	W
$T_j$	Junction Operating Temperature	-40 to 150	$^\circ C$
$T_{stg}$	Storage Temperature	-55 to 150	$^\circ C$
ERB	Power Mos Avalanche Energy	350	mJ

**CONNECTION DIAGRAMS**

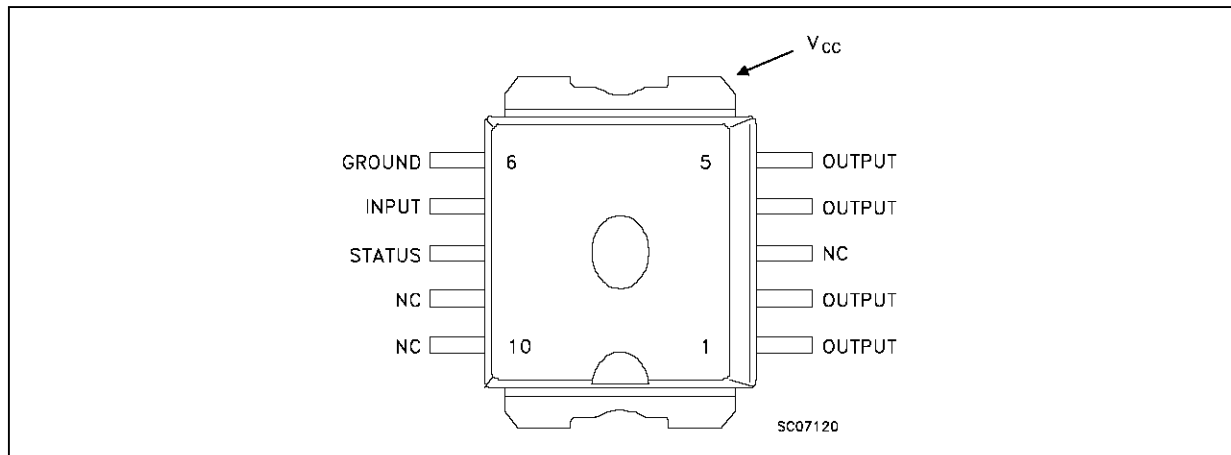

**CURRENT AND VOLTAGE CONVENTIONS**

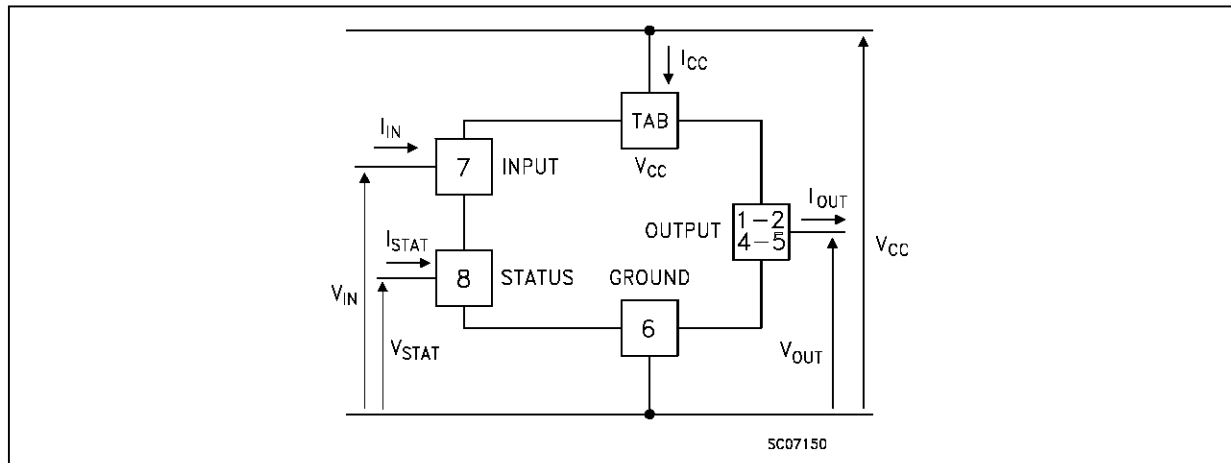

## THERMAL DATA

R <sub>thj-case</sub>	Thermal Resistance Junction-case	Max	2.4	°C/W
R <sub>thj-amb</sub>	Thermal Resistance Junction-ambient	Max	62.5	°C/W

ELECTRICAL CHARACTERISTICS (V<sub>CC</sub> = 9 to 36 V; -40 ≤ T<sub>j</sub> ≤ 125 °C unless otherwise specified)  
POWER

Symbol	Parameter	Test Conditions	Min.	Typ.	Max.	Unit
V <sub>CC</sub>	Supply Voltage	see note 1	5.5	13	36	V
R <sub>on</sub>	On State Resistance	I <sub>OUT</sub> = 6 A I <sub>OUT</sub> = 6 A T <sub>j</sub> = 25 °C			0.18 0.36	Ω Ω
I <sub>S</sub>	Supply Current	Off State T <sub>j</sub> ≥ 25 °C On State			50 15	μA mA
V <sub>Clamp</sub>	V <sub>CC</sub> - V <sub>OUT</sub>	I <sub>OUT</sub> = 6 A	40	45	55	V

## SWITCHING

Symbol	Parameter	Test Conditions	Min.	Typ.	Max.	Unit
t <sub>d(on)</sub>	Turn-on Delay Time Of Output Current	I <sub>OUT</sub> = 6 A Resistive Load Input Rise Time < 0.1 μs T <sub>j</sub> = 25 °C		15		μs
t <sub>r</sub>	Rise Time Of Output Current	I <sub>OUT</sub> = 6 A Resistive Load Input Rise Time < 0.1 μs T <sub>j</sub> = 25 °C		30		μs
t <sub>d(off)</sub>	Turn-off Delay Time Of Output Current	I <sub>OUT</sub> = 6 A Resistive Load Input Rise Time < 0.1 μs T <sub>j</sub> = 25 °C		20		μs
t <sub>f</sub>	Fall Time Of Output Current	I <sub>OUT</sub> = 6 A Resistive Load Input Rise Time < 0.1 μs T <sub>j</sub> = 25 °C		10		μs
(di/dt) <sub>on</sub>	Turn-on Current Slope	I <sub>OUT</sub> = 6 A I <sub>OUT</sub> = I <sub>OV</sub> 25 ≤ T <sub>j</sub> ≤ 140 °C			0.5 2	A/μs A/μs
(di/dt) <sub>off</sub>	Turn-off Current Slope	I <sub>OUT</sub> = 6 A I <sub>OUT</sub> = I <sub>OV</sub> 25 ≤ T <sub>j</sub> ≤ 140 °C			2 4	A/μs A/μs
V <sub>demag</sub>	Inductive Load Clamp Voltage	I <sub>OUT</sub> = 6 A L = 1 mH	-7	-4	-2	V

## LOGIC INPUT

Symbol	Parameter	Test Conditions	Min.	Typ.	Max.	Unit
V <sub>IL</sub>	Input Low Level Voltage				0.8	V
V <sub>IH</sub>	Input High Level Voltage		2		(*)	V
V <sub>I(hyst.)</sub>	Input Hysteresis Voltage			0.5		V
I <sub>IN</sub>	Input Current	V <sub>IN</sub> = 5 V			50	μA
V <sub>ICL</sub>	Input Clamp Voltage	I <sub>IN</sub> = 10 mA I <sub>IN</sub> = -10 mA		6 -0.7		V V

**ELECTRICAL CHARACTERISTICS** (Continued)  
**PROTECTION AND DIAGNOSTICS**

Symbol	Parameter	Test Conditions	Min.	Typ.	Max.	Unit
V <sub>STAT</sub> (•)	Status Voltage Output Low	I <sub>STAT</sub> = 1.6 mA			0.4	v
V <sub>USD</sub>	Under Voltage Shut Down				5.5	V
V <sub>SCL</sub> (•)	Status Clamp Voltage	I <sub>STAT</sub> = 10 mA I <sub>STAT</sub> = -10 mA		6 -0.7		V V
I <sub>OV</sub>	Over Current	R <sub>LOAD</sub> < 10 mΩ			20	A
I <sub>AV</sub>	Average Current in Short Circuit	R <sub>LOAD</sub> < 10 mΩ T <sub>c</sub> = 85 °C		1.4		A
I <sub>OL</sub>	Open Load Current Level		5		180	mA
T <sub>TSD</sub>	Thermal Shut-Down Temperature		140			°C
T <sub>R</sub>	Reset Temperature		125			°C

(\*) The V<sub>IH</sub> is internally clamped at 6V about. it is possible to connect this pin to an higher voltage via an external resistor calculated to not exceed 10 mA at the input pin.

(•) Status determination > 100 μs after the switching edge.

Note 1: Above V<sub>CC</sub> = 36V the output voltage is clamped to 36V. Power dissipation increases and the device turns off if junction temperature reaches thermal shutdown temperature.

**FUNCTIONAL DESCRIPTION**

The device has a diagnostic output which indicates open circuit (no load) and over temperature conditions. The output signals are processed by internal logic.

To protect the device against short circuit and over-current condition the thermal protection turns the integrated Power MOS off at a minimum junction temperature of 140 °C. When the temperature returns to about 125 °C the switch is automatically turned on again. To ensure the protection in all V<sub>CC</sub> conditions and in all the junction temperature range it is necessary to limit the voltage drop across Drain and Source (pin 3 and 5) at 29 V. The device is able to withstand a load dump according to the test pulse 5 at level III of the ISO TR/1 7631.

Above V<sub>CC</sub> = 36V the output voltage is clamped to 36V. Power dissipation increases and the device turns off if junction temperature reaches thermal shutdown temperature.

**PROTECTING THE DEVICE AGAINST REVERSE BATTERY**

The simplest way to protect the device against a continuous reverse battery voltage (-26V) is to

insert a Schottky diode between pin 1 (GND) and ground, as shown in the typical application circuit (fig. 3).

The consequences of the voltage drop across this diode are as follows:

- If the input is pulled to power GND, a negative voltage of -V<sub>F</sub> is seen by the device. (V<sub>IL</sub>, V<sub>IH</sub> thresholds and V<sub>STAT</sub> are increased by V<sub>F</sub> with respect to power GND).
- The undervoltage shutdown level is increased by V<sub>F</sub>.

If there is no need for the control unit to handle external analog signals referred to the power GND, the best approach is to connect the reference potential of the control unit to node [1] (see application circuit in fig. 4), which becomes the common signal GND for the whole control board.

In this way no shift of V<sub>IH</sub>, V<sub>IL</sub> and V<sub>STAT</sub> takes place and no negative voltage appears on the INPUT pin; this solution allows the use of a standard diode, with a breakdown voltage able to handle any ISO normalized negative pulses that occurs in the automotive environment.

**TRUTH TABLE**

	INPUT	OUTPUT	DIAGNOSTIC
Normal Operation	L	L	H
	H	H	H
Open Circuit (No Load)	L	L	H
	H	H	L
Over-temperature	L	L	H
	H	L	L
Under-voltage	X	L	H
	X	L	H

**Figure 1: Waveforms**

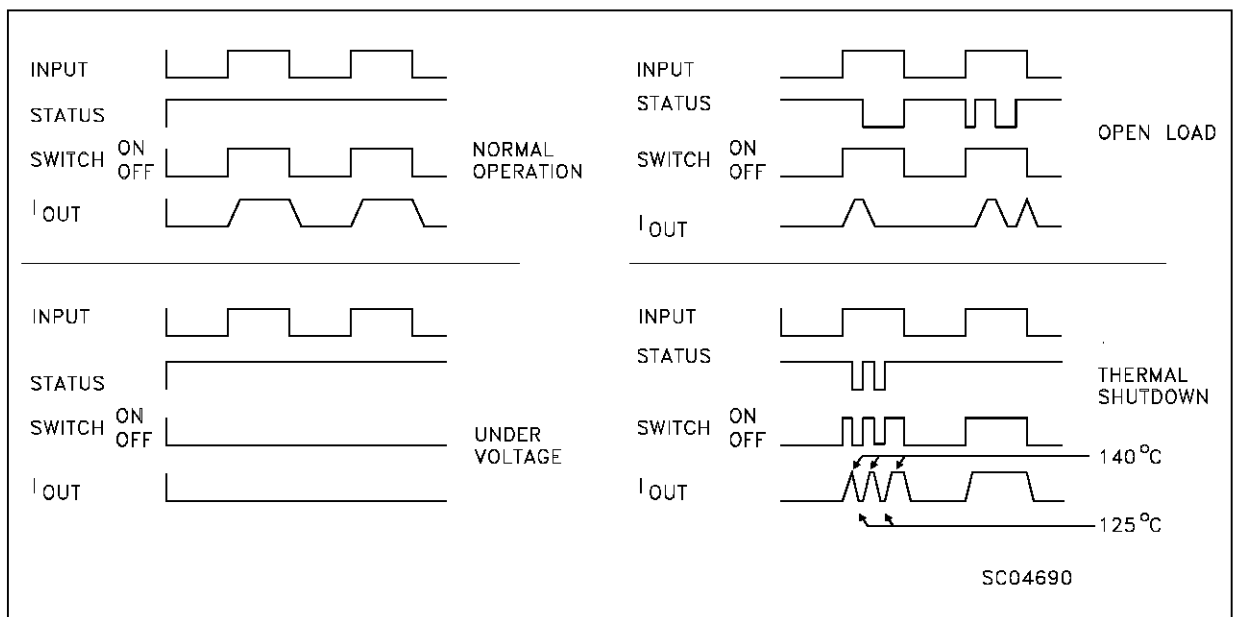

**Figure 2: Over Current Test Circuit**

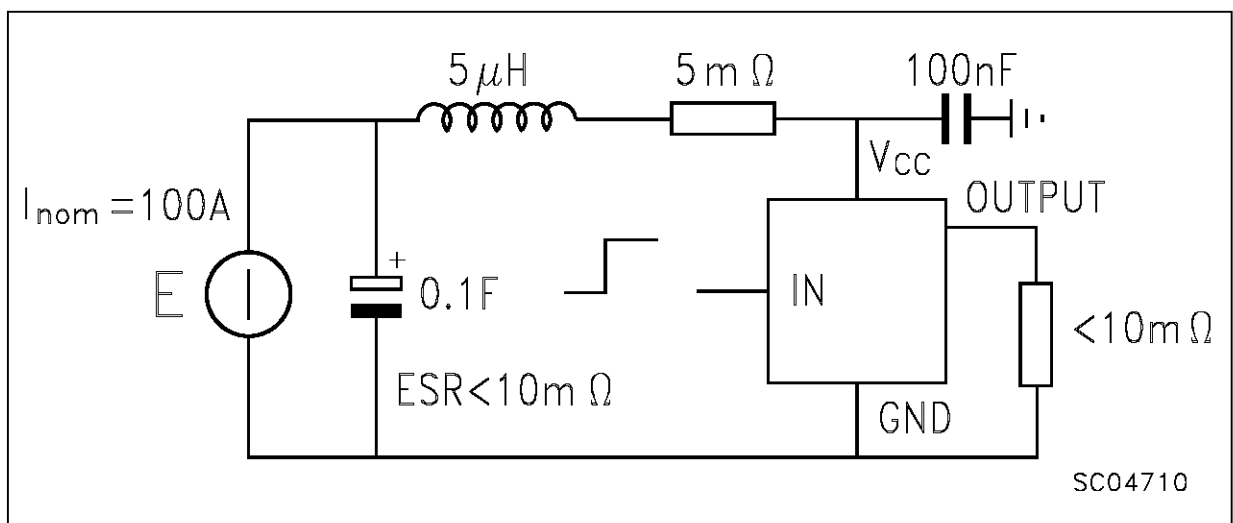

Figure 3: Typical Application Circuit With A Schottky Diode For Reverse Supply Protection

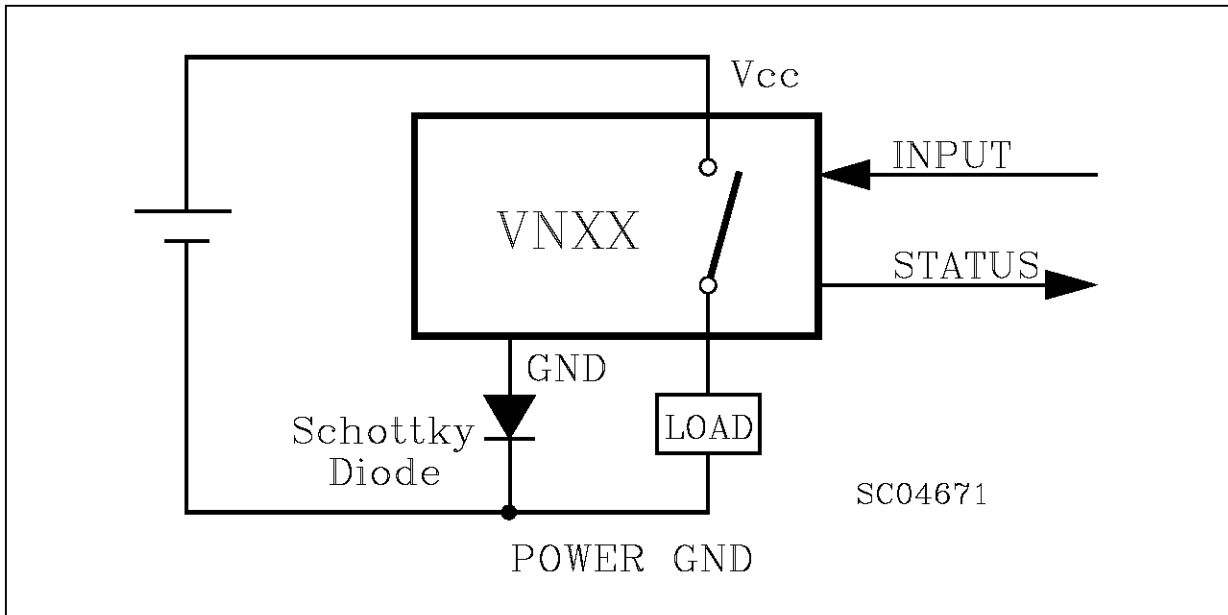
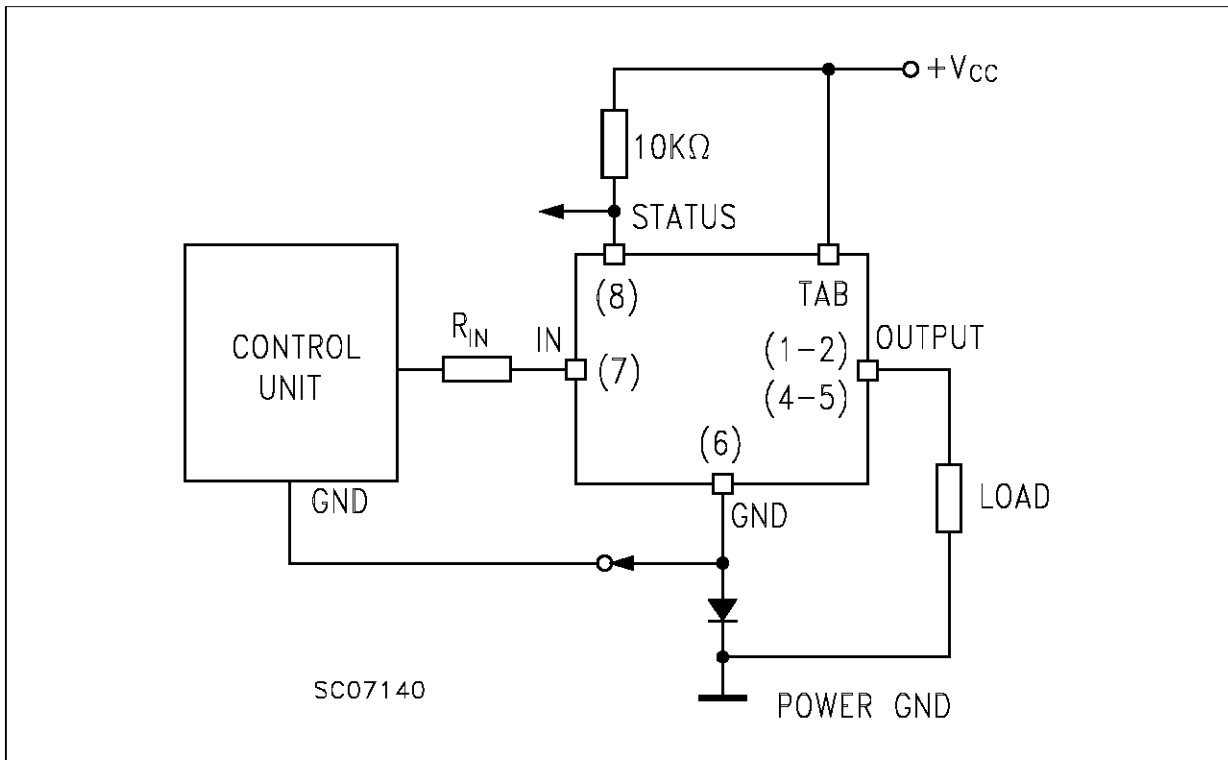
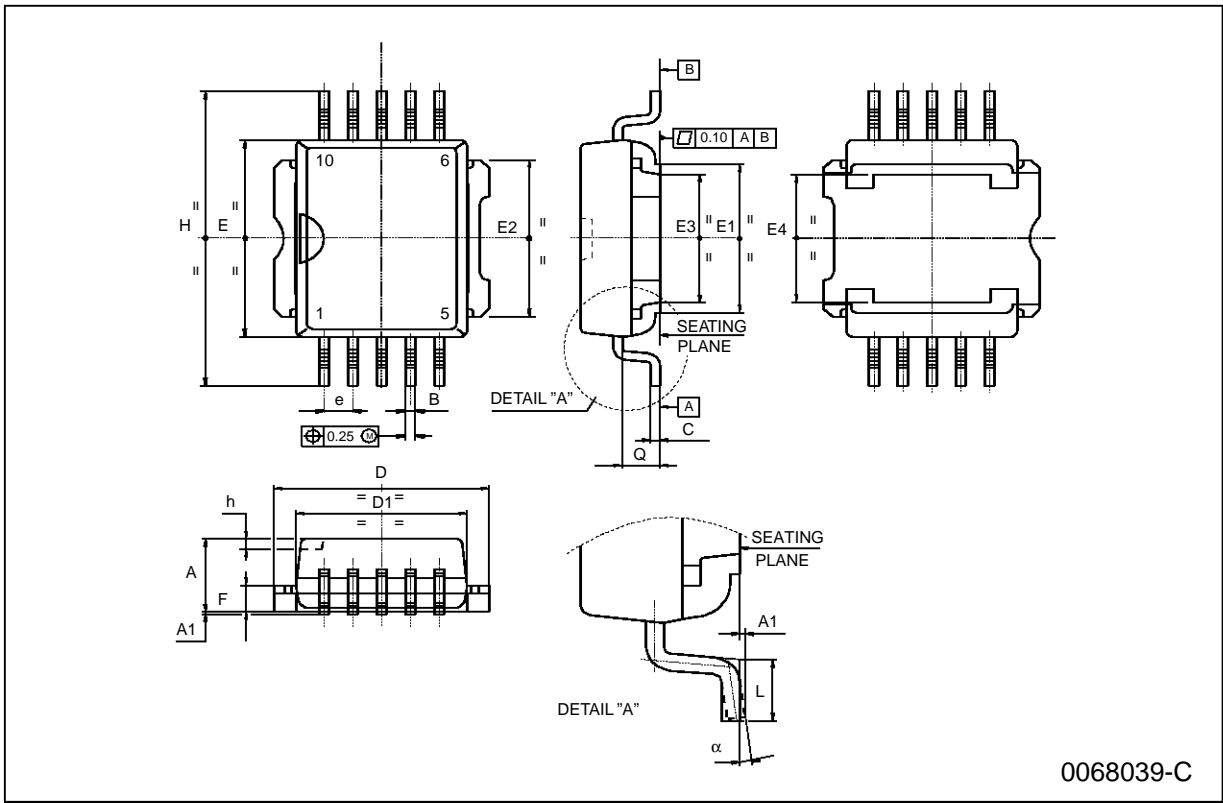

Figure 4: Typical Application Circuit With Separate Signal Ground



**PowerSO-10 MECHANICAL DATA**

DIM.	mm			inch		
	MIN.	TYP.	MAX.	MIN.	TYP.	MAX.
A	3.35		3.65	0.132		0.144
A1	0.00		0.10	0.000		0.004
B	0.40		0.60	0.016		0.024
c	0.35		0.55	0.013		0.022
D	9.40		9.60	0.370		0.378
D1	7.40		7.60	0.291		0.300
E	9.30		9.50	0.366		0.374
E1	7.20		7.40	0.283		0.291
E2	7.20		7.60	0.283		0.300
E3	6.10		6.35	0.240		0.250
E4	5.90		6.10	0.232		0.240
e		1.27			0.050	
F	1.25		1.35	0.049		0.053
H	13.80		14.40	0.543		0.567
h		0.50			0.002	
L	1.20		1.80	0.047		0.071
q		1.70			0.067	
$\alpha$	0°		8°			



Information furnished is believed to be accurate and reliable. However, SGS-THOMSON Microelectronics assumes no responsibility for the consequences of use of such information nor for any infringement of patents or other rights of third parties which may result from its use. No license is granted by implication or otherwise under any patent or patent rights of SGS-THOMSON Microelectronics. Specifications mentioned in this publication are subject to change without notice. This publication supersedes and replaces all information previously supplied. SGS-THOMSON Microelectronics products are not authorized for use as critical components in life support devices or systems without express written approval of SGS-THOMSON Microelectronics

© 1997 SGS-THOMSON Microelectronics - Printed in Italy - All Rights Reserved

SGS-THOMSON Microelectronics GROUP OF COMPANIES

Australia - Brazil - Canada - China - France - Germany - Hong Kong - Italy - Japan - Korea - Malaysia - Malta - Morocco - The Netherlands - Singapore - Spain - Sweden - Switzerland - Taiwan - Thailand - United Kingdom - U.S.A