

Product Brief VSC215

Enhanced IPMI Baseboard Management Controller

Features

- IPMI 1.0 and 1.1 Compatible
- LPC and X-Bus System Interfaces
- Block Transfer, KCS and SMIC Logical Interfaces
- 32-bit, RISC CPU w/Debug Port
- Four IPMB or Multi-Master I²C Interfaces
- Three General Purpose UARTs: one with ICMB, one with Modem Control, one for Serial ICE Debug
- 8 Input 10-bit ADC, 8 Optional PWM Outputs and 8 Optional Fan Tachometer Inputs
- Up to 50 (depends on configuration) Programmable General Purpose I/Os with up to 10 External Interrupts
- Secondary Timer with Optional External Count Source
- User Definable Clock from 20-50MHz
- PLL for use with Low Frequency/Cost Crystals
- Internal 8KB user data SRAM
- Flexible External Memory Interface with Four 1MB Address Ranges
- External Flash and/or SRAM (60ns to 350ns)
- 144 Pin PQFP Packaging

General Description

The VSC215 is an embedded controller tailored for Intelligent Platform Management Interface (IPMI) Baseboard Management Controller (BMC) applications. The feature set selection and flexibility of this device makes it the perfect BMC solution for entry through high-end servers. No additional logic is required to interface the VSC215 into Intel-Architecture (IA) servers and workstations supporting LPC or X-Bus. Four I²C serial multi-master controllers and three UARTs allow system designers to mix and match IPMB, ICMB and private I²C configurations to best meet the requirements of a particular system. The VSC215 includes a high performance, 32-bit RISC processor, which provides the processing bandwidth and addressability required for sophisticated platform management strategies. The Software Development Kit (SDK) and evaluation board allow for reduced development cycles, high code reuse between implementations and faster time-to-market.

VSC215 Based IPMI Server Baseboard Architecture

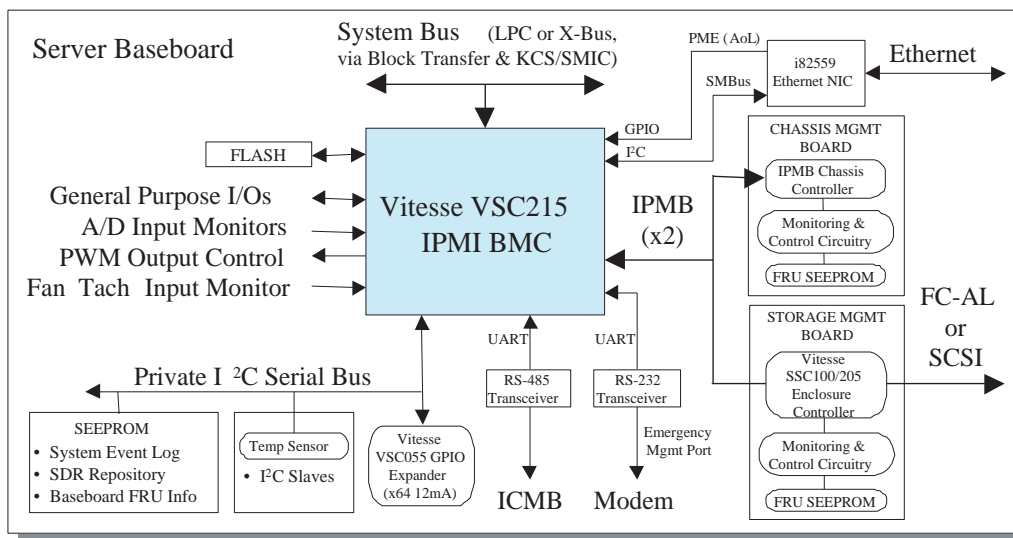

Applications

The VSC215 is an ideal Baseboard Management Controller for server management applications. The VSC215 and related Software Development Kit (SDK) implement the IPMI 1.0/1.1 specification for BMCs. The VSC215 may also be used in applications other than IPMI through firmware modifications.

Figure 1: Functional Block Diagram

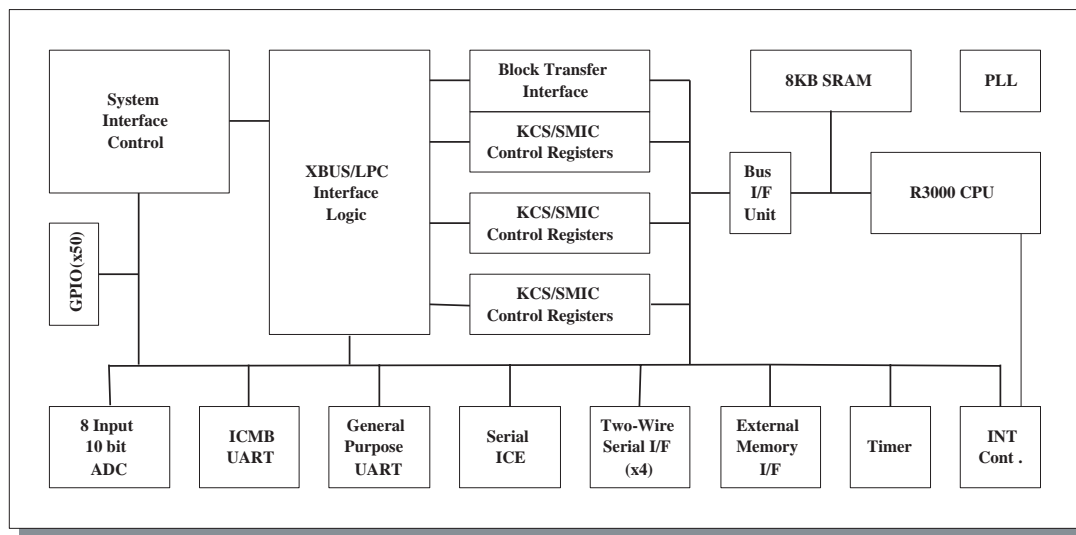

Architecture

System Level Integration (SLI) techniques were used to create a complete system on a chip. The VSC215 is based on Vitesse's proven architecture for enclosure and platform management solutions. It integrates an embedded RISC processor, a flexible system interface, memory and multiple peripheral interfaces to create an embedded system for server platform management.

The VSC215 includes four, I²C multi-master bus controllers. These controllers may be used to interface to off-the-shelf instrumentation and control devices commonly used in environmental monitoring and management applications such as Vitesse's SSC050/VSC055 I²C Backplane Controllers. The controllers also support direct connection to Intelligent Platform Management Buses (IPMB).

The VSC215 requires off chip memory for firmware code storage. Most applications will use flash memory devices for non-volatile storage. Static RAM may be added for higher performance applications. The VSC215 has four external chip selects each with a one-megabyte address range.

The VSC215 integrates three UARTs. One port can be used to control a modem. A second port fully implements the Intelligent Chassis Management Bus (ICMB) defined by IPMI. A third could be used as a Serial-ICE interface for firmware debug and development. The Vitesse provided Software Development Kit includes ROM Monitor and firmware download functionality via the UARTs.

Software

The software designed to execute on the VSC215 determines the characteristics of the overall server management solution. Most server management applications will be unique to a customer's individual product. The VSC215 firmware architecture uses a Personality Module which captures the unique functionality required by a particular application. Vitesse provides a Software Development Kit (SDK) to customers to assist their development of their Personality Module.

The SDK includes software to implement KCS and System Management Interface Chip (SMIC) transport and IPMI diagnostic environment. In addition, the SDK also includes a System Services module which provides APIs to the peripheral functionality (interrupts, timers etc.) in the VSC215. The System Services also includes driver libraries for popular I²C devices such as National's LM75, LM78, and many others

Software Development Kit Features

1. Abstracts IPMI Message handling to easy to use APIs
2. Modular architecture to support migration to other I/O technologies and protocols
3. Extensive peripheral device library
4. Sample Personality Module source code

Figure 2: SDK Firmware Block Diagram

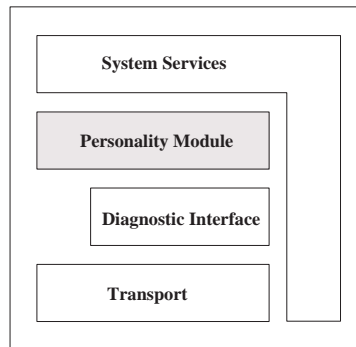

For More Information:

1. www.vitesse.com
2. email: prodinfo@vitesse.com
3. TEL: 1-800-VITESSE

Notice

Vitesse Semiconductor Corporation reserves the right to make changes in its products, specifications or other information at any time without prior notice. Therefore the reader is cautioned to confirm that this Product Brief is current prior to placing any orders. The company assumes no responsibility for any circuitry described other than circuitry entirely embodied in the Vitesse product. Please contact Vitesse Semiconductor to obtain the latest product status and most recent specification for this product.

Warning

Vitesse Semiconductor Corporation's product are not intended for use in life support appliances, devices or systems. Use of a Vitesse product in such applications without the written consent is prohibited.