

# 1 to 4 Gbps TIAs

VITESSE

## 1 to 4 Gbps Transimpedance Amplifiers with Photocurrent Monitor

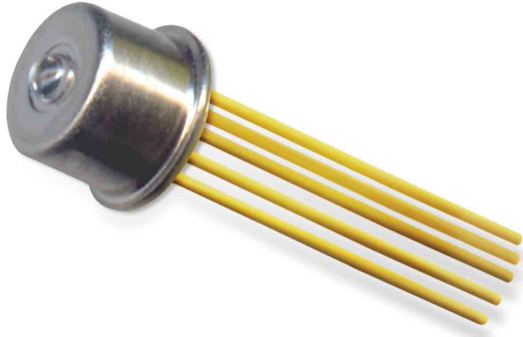

### PRODUCT FAMILY:

- ▶ VSC7773 ▶ VSC7970
- ▶ VSC7971 ▶ VSC7972
- ▶ VSC7973

### APPLICATIONS:

- ▶ Gigabit Ethernet Transceivers
- ▶ Fibre Channel Transceivers (1x, 2x and 4x)
- ▶ SONET/SDH Transceivers
- ▶ SONET/SDH Transponders
- ▶ 4.25 Gbps Receiver Optical Sub-Assemblies

### FEATURES:

- ▶ Single +3.3 V Supply
- ▶ 5 kΩ Differential Transimpedance
- ▶ Low Power Consumption for SFP/SFF Applications
- ▶ Differential Outputs with Linear Current Monitor
- ▶ Available as Bare Dice or in a 4-pin or 5-pin TO-46 Package

### BENEFITS:

- ▶ Source Terminated Differential Outputs With Linear Photocurrent Monitor Offers Diagnostic Capabilities Without Sacrificing High Signal Integrity
- ▶ On-chip Filter Provides Positive Bias to the Photodetector, Eliminating the Need for External Components, Saving Space and Cost
- ▶ Available in a TO-46 Package, Eliminating Time and Costs Associated With the Design, Assembly and Test of the Receiver

### SPECIFICATIONS:

- ▶ Input Noise: 550 nA (rms)
- ▶ Supply Current: 25 mA
- ▶ Sensitivity : -23 dBm (long wave) -21.5 dBm (short wave)
- ▶ Max Input Current: 2.2 mA Peak to Peak Current
- ▶ Power Dissipation: 82.5 mW
- ▶ Supply Voltage: 3.3 V
- ▶ Operating Temperature from -40°C to 85°C

- VSC7773: TO-46 (with 850nm PIN detector)
- VSC7970: Dice or TO-46 (with 1310nm/1550nm PIN detector)
- VSC7971: Dice or TO-46 (with 1310nm/1550nm PIN detector)
- VSC7972: Dice or TO-46 (with 850nm pin detector)
- VSC7973: Dice or TO-46 (with 850nm pin detector)

### BLOCK DIAGRAM (Die):

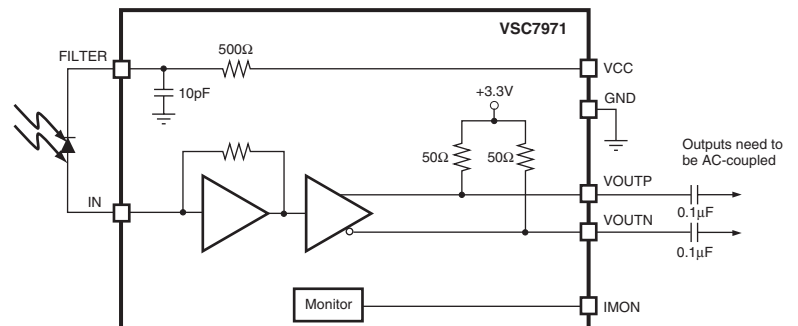

# 1 to 4 Gbps TIAs

## 1 to 4 Gbps Transimpedance Amplifiers with Photocurrent Monitor

### GENERAL DESCRIPTION:



The VSC7773, VSC7970, VSC7971, VSC7972, and VSC7973 are high performance Transimpedance Amplifiers (TIA) for Ethernet, Fibre Channel and SONET applications. The VSC7773 support rates from 1 Gbps to 4.25 Gbps. The other parts support rates up to 2.5 Gbps. They feature 5 k $\Omega$  differential transimpedance and 1.8 GHz bandwidth with source-terminated differential outputs. All five parts have a linear current monitor, adding diagnostic capabilities, and simplifying optical alignment during the manufacturing process. A space saving filter connection is provide for positive bias to the photodetector through an on-chip 500 $\Omega$  resistor to VCC, allowing for easy assembly on a TO-46 header.

### APPLICATION DIAGRAM:

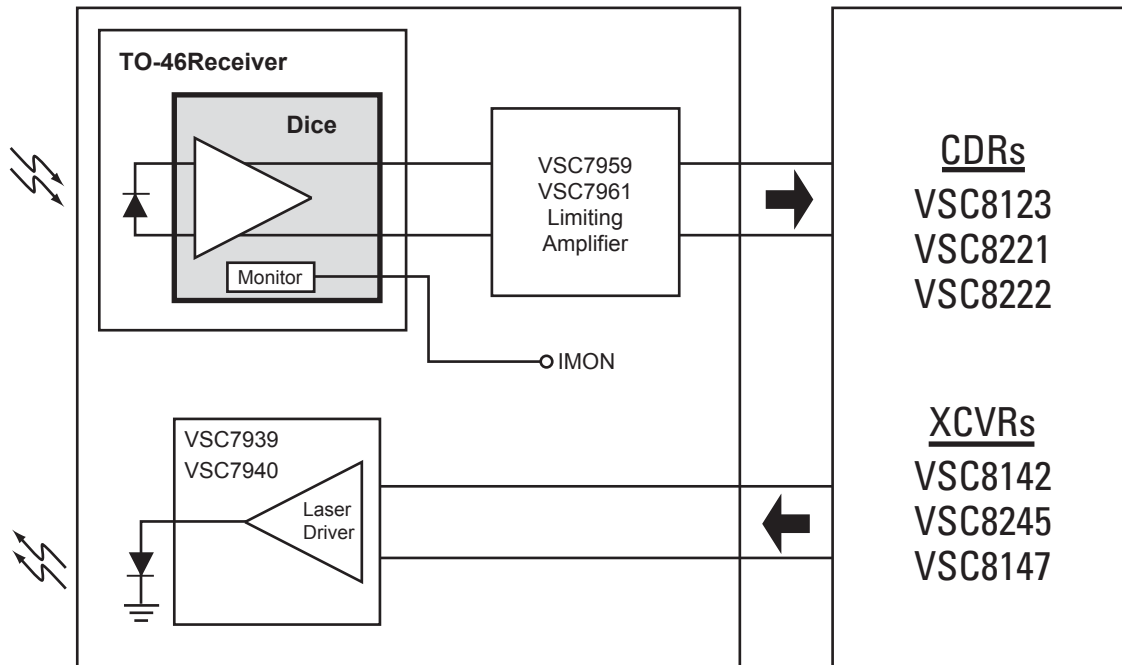

For more information on Vitesse Products visit the Vitesse web site at [www.vitesse.com](http://www.vitesse.com) or contact Vitesse Sales at (800) VITESSE or [sales@vitesse.com](mailto:sales@vitesse.com)

©2004 Vitesse Semiconductor Corporation

Vitesse, ASIC-Friendly, FibreTimer, TimeStream and Snoop Loop are trademarks of Vitesse Semiconductor Corporation. All other trademarks or registered trademarks mentioned herein are the property of their respective holders. Vitesse Semiconductor Corporation ("Vitesse") retains the right to make changes to its products or specifications to improve performance, reliability or manufacturability. All information in this document, including descriptions of features, functions, performance, technical specifications and availability, is subject to change without notice at any time.

# VITESSE

741 Calle Plano  
Camarillo, CA 93012, USA  
Tel: +1 805.388.3700  
Fax: +1 805.987.5896  
[www.vitesse.com](http://www.vitesse.com)