

VSC8141

Multi-Rate 16:1 SONET/SDH Transceiver with Integrated Clock Generator

Features

- Multi-Rate Transceiver for SONET OC-48, OC-24 OC-12, OC-3, and Gigabit Ethernet Rates
- 16-Bit LVPECL Low-Speed Interface
- On-Chip PLL-Based Clock Generator
- High-Speed Clock Output Power-Down Option
- Equipment, Facility and Split Loopback Modes
- Loss of Signal (LOS) Detect Input
- Exceeds Bellcore Jitter Specifications
- Single 3.3V Power Supply
- 1.8 W Typical Power Dissipation
- Packages: 128-Pin PQFP (14x20x2mm) or 208-Pin TBGA 23x23x1.55mm)

General Description

The VSC8141 is a SONET/SDH compatible 3.3V multi-rate transceiver with integrated clock generator for use in SONET/SDH systems operating at OC-48, OC-24, OC-12, OC-3, or Gigabit Ethernet data rates. The internal clock generator uses a phase-locked loop (PLL) to multiply either a 77.76MHz or 155.52MHz reference clock for internal logic and output retiming. The 16-bit parallel LVPECL interface incorporates an on-board FIFO to address loop timing design issues. Facility and Equipment Loopbacks can be configured separately or simultaneously. The VSC8141 supports 3.3V operation with 2.3 Watts maximum power (1.8 Watts typical) and is packaged in a thermally-enhanced 128-pin PQFP or 208-pin TBGA package.

Block Diagram

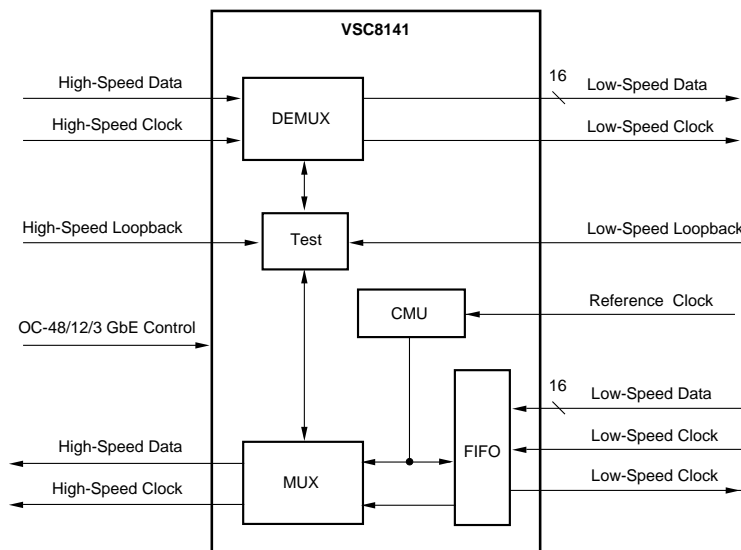

Order Information

Product	Package
VSC8141QR	128-Pin PQFP, 14x20mm
VSC8141TW	208-Pin TBGA, 23x23mm

Notice

Vitesse Semiconductor Corporation ("Vitesse") provides this document for informational purposes only. This document contains pre-production information about Vitesse products in their concept, development and/or testing phase. All information in this document, including descriptions of features, functions, performance, technical specifications and availability, is subject to change without notice at any time. Nothing contained in this document shall be construed as extending any warranty or promise, express or implied, that any Vitesse product will be available as described or will be suitable for or will accomplish any particular task. Vitesse products are not intended for use in life support appliances, devices or systems. Use of a Vitesse product in such applications without written consent is prohibited.