

**Winbond**  
**Mobile Keyboard and**  
**Embedded Controller**

**W83L951DG**  
**W83L951FG**

Date: August/2006 Revision: 1.00

# W83L951DG/W83L951FG



## W83L951DG/W83L951FG Data Sheet Revision History

|    | PAGES | DATES    | VERSION | WEB VERSION | MAIN CONTENTS |
|----|-------|----------|---------|-------------|---------------|
| 1  | n.a.  | 8/7/2006 | 1.0     | 1.0         | First Release |
| 2  |       |          |         |             |               |
| 3  |       |          |         |             |               |
| 4  |       |          |         |             |               |
| 5  |       |          |         |             |               |
| 6  |       |          |         |             |               |
| 7  |       |          |         |             |               |
| 8  |       |          |         |             |               |
| 9  |       |          |         |             |               |
| 10 |       |          |         |             |               |



## Table of Contents-

|       |   |    |
|-------|---|----|
| 1.    | GENERAL DESCRIPTION .....                       | 1  |
| 2.    | PRODUCT FEATURES .....                          | 2  |
| 3.    | BLOCK DIAGRAM .....                             | 4  |
| 4.    | PIN CONFIGURATION FOR W83L951DG/W83L951FG ..... | 5  |
| 5.    | PIN DESCRIPTION.....                            | 7  |
| 5.1   | Pin configuration table.....                    | 7  |
| 5.2   | RESET# & TEST# Part.....                        | 15 |
| 5.3   | LPC Interface Part.....                         | 16 |
| 5.4   | GPIO0 Part .....                                | 16 |
| 5.5   | GPIO1 Part .....                                | 18 |
| 5.6   | GPIO2 Part .....                                | 19 |
| 5.7   | GPIO3 Part .....                                | 20 |
| 5.8   | GPIO4 Part .....                                | 21 |
| 5.9   | GPIO5 Part .....                                | 22 |
| 5.10  | GPIO6 Part .....                                | 22 |
| 5.11  | GPIO7 Part .....                                | 23 |
| 5.12  | GPIO8 Part .....                                | 24 |
| 5.13  | GPIO9 Part .....                                | 25 |
| 5.14  | GPIOA Part.....                                 | 26 |
| 5.15  | GPIOB Part.....                                 | 26 |
| 5.16  | GPIOC Part .....                                | 27 |
| 5.17  | Power & Clock Part .....                        | 28 |
| 6.    | FUNCTIONAL DESCRIPTION.....                     | 29 |
| 6.1   | Turbo 8051 Core Block .....                     | 31 |
| 6.1.1 | Register Description .....                      | 32 |
| 6.2   | Low Pin Count Interface Block.....              | 38 |
| 6.2.1 | Register Description .....                      | 38 |
| 6.3   | Personal System 2 Block .....                   | 43 |
| 6.3.1 | Register Description .....                      | 43 |
| 6.4   | System Management Bus Block.....                | 48 |
| 6.4.1 | Register Description .....                      | 49 |
| 6.5   | Internal Interrupt Controller Block .....       | 53 |
| 6.5.1 | Register Description .....                      | 54 |
| 6.6   | GPIOs Block.....                                | 57 |
| 6.6.1 | GPIO Data Register Description.....             | 58 |
| 6.6.2 | GPIO Direction Register Description .....       | 61 |
| 6.7   | Watch Dog Block.....                            | 63 |
| 6.7.1 | Register Description .....                      | 63 |

# W83L951DG/W83L951FG



|        |  |     |
|--------|--|-----|
| 6.8    | Timer Block.....                                     | 65  |
| 6.8.1  | Register Description .....                           | 65  |
| 6.9    | Pulse Width Modulator Block.....                     | 69  |
| 6.9.1  | Register Description .....                           | 70  |
| 6.10   | UART Block.....                                      | 72  |
| 6.10.1 | Register Description .....                           | 72  |
| 6.11   | Consumer Infrared Communications Receiver Block..... | 75  |
| 6.11.1 | Register Description .....                           | 75  |
| 6.12   | A/D Converter Block.....                             | 80  |
| 6.12.1 | Register Description .....                           | 80  |
| 6.13   | D/A Converter Block.....                             | 81  |
| 6.13.1 | Register Description .....                           | 81  |
| 6.14   | Fan Tachometer Block.....                            | 82  |
| 6.14.1 | Register Description .....                           | 82  |
| 6.15   | Real Time Clock Generator Block.....                 | 83  |
| 6.15.1 | Register Description .....                           | 83  |
| 6.16   | External Interrupt Control Block.....                | 85  |
| 6.16.1 | Register Description .....                           | 85  |
| 6.17   | Flash Memory.....                                    | 88  |
| 6.17.1 | External Programming Mode.....                       | 88  |
| 6.17.2 | Internal Programming Mode.....                       | 88  |
| 6.17.3 | Device Bus Operation.....                            | 89  |
| 6.17.4 | Command Definitions .....                            | 89  |
| 6.17.5 | Write Operation Status.....                          | 91  |
| 6.17.6 | Table of Operating Modes.....                        | 92  |
| 6.17.7 | Embedded Algorithm.....                              | 93  |
| 6.17.8 | Timing Parameters .....                              | 96  |
| 6.17.9 | Timing Waveforms.....                                | 97  |
| 7.     | SPECIFICATIONS .....                                 | 101 |
| 7.1    | Absolute Maximum Ratings .....                       | 101 |
| 7.2    | Analog Characteristics .....                         | 101 |
| 7.2.1  | ADC Characteristics .....                            | 101 |
| 7.2.2  | DAC Characteristics .....                            | 101 |
| 7.3    | Power Supply Current Consumption .....               | 101 |
| 7.4    | DC Characteristics .....                             | 102 |
| 8.     | ORDERING INSTRUCTION .....                           | 104 |
| 9.     | HOW TO READ THE TOP MARKING .....                    | 105 |
| 10.    | PACKAGE DIMENSIONS.....                              | 106 |
| 11.    | DEMO CIRCUITS .....                                  | 107 |

# W83L951DG/W83L951FG



## 1. GENERAL DESCRIPTION

The Winbond mobile keyboard and embedded controller W83L951DG/FG architecture consists of a Turbo-8051 core logic controller and surrounded by various components, 2K+256 bytes of RAM, 64K on-chip FLASH, LPC host interface, 13 general purpose I/O port with 24 external interrupt source, 4 timers, 1 serial port, 2 SMBus interface for master mode, 3 PS/2 port, 2 PWM channels with 8-bits and 2 PWM channels with 16-bits, 2 D-A and 8 A-D converters, 1 Consumer Infrared Communications Receiver, 2 Fan Tachometer , 1 Real Time Clock Generator, and Matrix Interface. The part number with an affix of "G" is the Lead-free package product.



## 2. PRODUCT FEATURES

- Core logic
  - 8-bit Turbo 8052 Microprocessor Code based, Speed up to 24MHz
  - 256 bytes Internal RAM
  - 64K bytes Embedded Programmable Flash Memory
  - 2K bytes External SRAM
  
- Host interface
  - Software Optional with LPC Interface
  - Primary Programmable I/O Address Communication Port in LPC Mode
  - Support SERIRQ in LPC Interface
  - Support Hardware Fast Gate A20 and KBRST
  - Support Port 92h
  
- SMBus
  - Support 2 SMBus Interface support Master Mode.
  
- Timers
  - Support Four Timer Signal with Three Pre-scalars
  - Timer 1 and 2 Share the Same Pre-scalar and are Free-Running Only.
  - Timer X and Y Have Individual Pre-scalar and Support up to Four Control Modes, Free Running, Pulse Output, Event Counter and Pulse Width Measurement
  
- PWM
  - Support Four PWM Channels
  - PWM 0 and 1 are 8-bits and Programmable Frequency from 62Hz to 7.5 KHz
  - PWM 2 and 3 are 16-bits and Programmable Frequency from 6Hz to 3MHz
  
- Fan Tachometer
  - Support two Fan Tachometer Inputs
  
- A/D Converter
  - Firmware Programmable Optional with 10-bit or 8-bit Resolution
  - Support Eight Channels

# W83L951DG/W83L951FG



- D/A Converter
  - 8-bit Resolution
  - Support Two Channels
  
- PS2
  - Support Three Hardware PS2 Channels
  - Optional PS2 Clock Inhibit by Hardware or Firmware
  
- Keyboard Controller
  - Support 16\*8 Keyboard Matrix-scan, Expanding to 18\*8 and 20\*8
  
- GPIO
  - Support 104 Useful GPIO Pins Totally and Bit-addressable to Facility Firmware Coding
  
- FLASH
  - Support External On-Board 64K Flash via Matrix Interface (GP0, 1, 3)
  
- CIR
  - Support Decoding for the NEC Consumer IR Remote Control Format
  
- RTC
  - Real Time Clock Generator with 32.768 KHz Input
  
- ACPI
  - Support ACPI Appliance
  - Secondary Programmable I/O Address Communication Port in LPC Mode
  
- Package
  - Pin QFP and 128-Pin LQFP Leadfree Package Options, in compliance with the RoHS (Restriction on Hazardous Substances)



## 3. BLOCK DIAGRAM

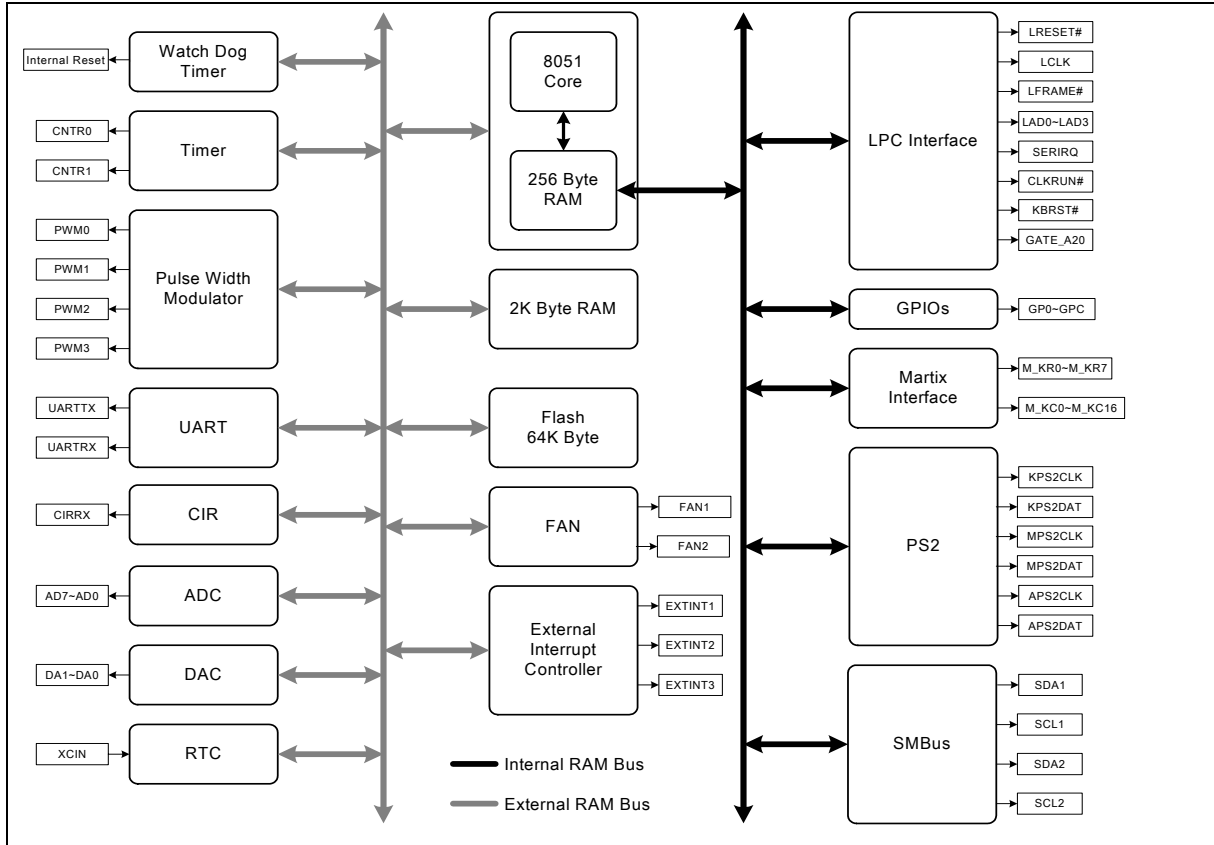

**Note:** This Block Diagram should not be used for pin count.



# W83L951DG/W83L951FG



## 4. PIN CONFIGURATION FOR W83L951DG/W83L951FG

128-Pin Low Profile Quad Flat Pack (LQFP)

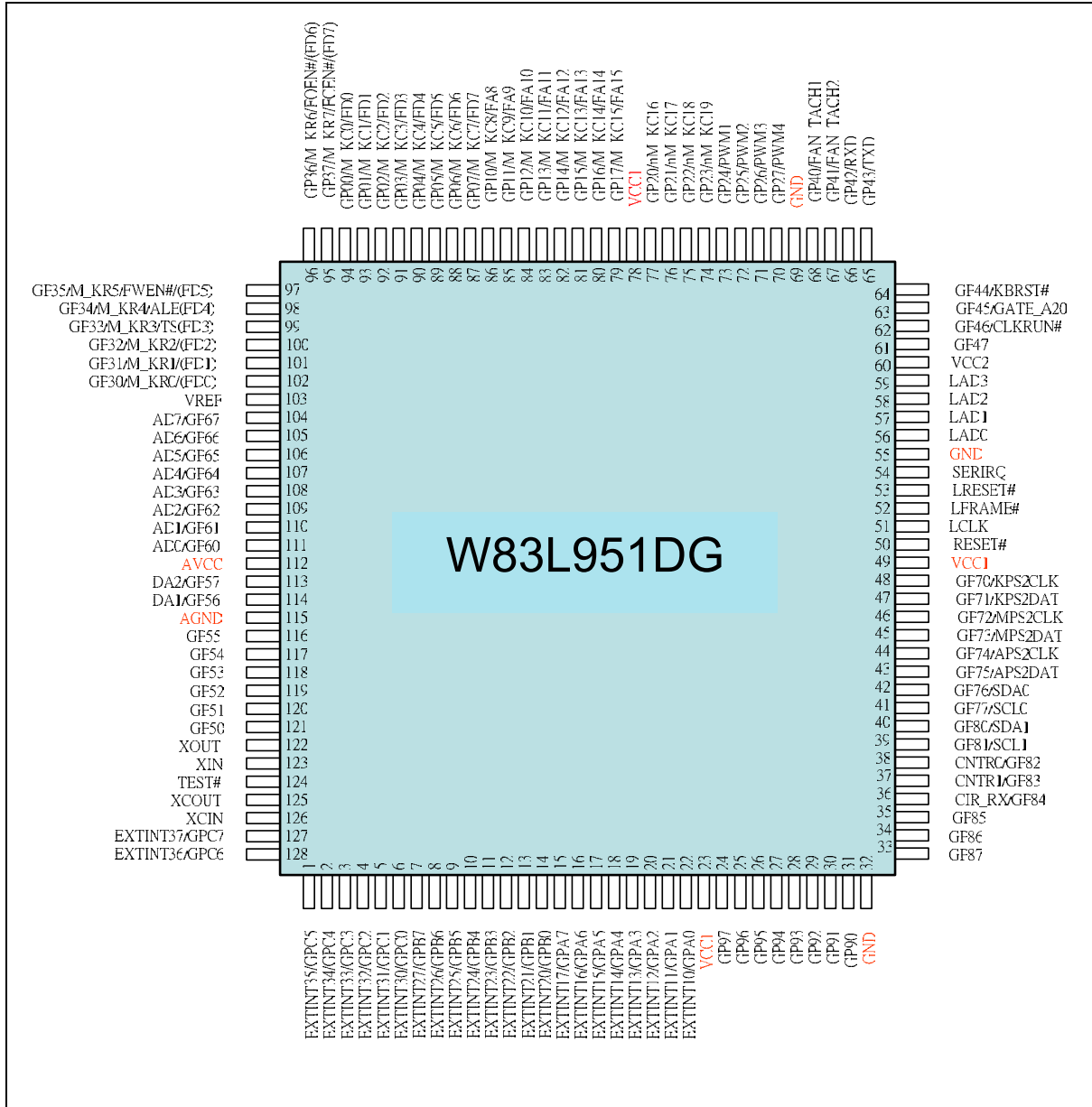

Note: The Pin Configuration is only for 128-pin LQFP Package.

## 128-Pin Quad Flat Pack (QFP)

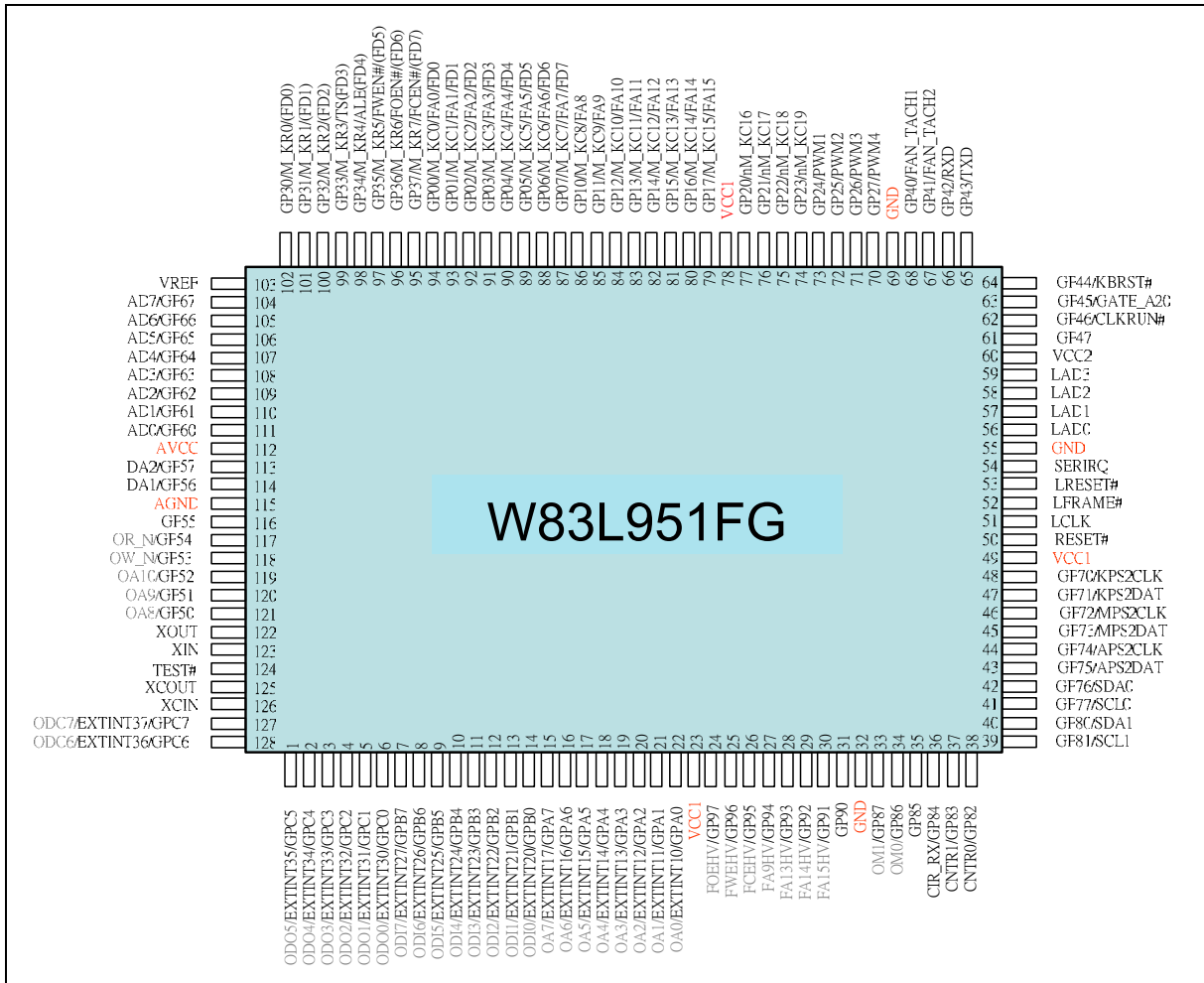

**Note:** The Pin Configuration is only for 128-pin QFP Package.



## 5. PIN DESCRIPTION

Table 5-1 Pin Type Description

| TYPE                            | DESCRIPTION  |
|---------------------------------|--|
| I/O <sub>12tsm</sub>            | Bi-directional pin, TTL level, Schmitt-trigger input, selectable 250uA/12mA sink capability, 12mA select source capability |
| I/O <sub>12tsai</sub>           | Bi-directional pin, TTL level, Schmitt-trigger input, Analog Input, 12mA source-sink capability                            |
| I/O <sub>12tsao</sub>           | Bi-directional pin, TTL level, Schmitt-trigger input, Analog Output, 12mA source-sink capability                           |
| I/O <sub>16tsh</sub>            | Bi-directional pin, TTL level, Schmitt-trigger input, 5V Tolerant, 16mA source-sink capability                             |
| I/O <sub>24ts</sub>             | Bi-directional pin, Schmitt-trigger input, 24mA source-sink capability   |
| I <sub>ts</sub>                 | TTL level, Schmitt-trigger input   |
| I <sub>c</sub> , O <sub>c</sub> | Clock Input, Clock Out   |
| I <sub>vdd</sub>                | Voltage Input  |
| I <sub>vss</sub>                | Ground Input   |

**Note:** t – TTL level, s – Schmitt-trigger, m – matrix keyboard, ai – analog input, ao – analog output, h – 5V Tolerant, c – clock.

### 5.1 Pin configuration table

Table 5-2 Pin configuration table

| SYMBOL           | PIN | I/O      | FUNCTION   |
|------------------|-----|----------|--|
| GPC5<br>EXTINT35 | 1   | I/O16tsh | General Purpose I/O Function<br>External Interrupt Input |
| GPC4<br>EXTINT34 | 2   | I/O16tsh | General Purpose I/O Function<br>External Interrupt Input |
| GPC3<br>EXTINT33 | 3   | I/O16tsh | General Purpose I/O Function<br>External Interrupt Input |
| GPC2<br>EXTINT32 | 4   | I/O16tsh | General Purpose I/O Function<br>External Interrupt Input |
| GPC1<br>EXTINT31 | 5   | I/O16tsh | General Purpose I/O Function<br>External Interrupt Input |
| GPC0<br>EXTINT30 | 6   | I/O16tsh | General Purpose I/O Function<br>External Interrupt Input |
| GPB7<br>EXTINT27 | 7   | I/O16tsh | General Purpose I/O Function<br>External Interrupt Input |

# W83L951DG/W83L951FG



Pin configuration table, continued.

| SYMBOL           | PIN | I/O      | FUNCTION   |
|------------------|-----|----------|--|
| GPB6<br>EXTINT26 | 8   | I/O16tsh | General Purpose I/O Function<br>External Interrupt Input |
| GPB5<br>EXTINT25 | 9   | I/O16tsh | General Purpose I/O Function<br>External Interrupt Input |
| SYMBOL           | PIN | I/O      | FUNCTION   |
| GPB4<br>EXTINT24 | 10  | I/O16tsh | General Purpose I/O Function<br>External Interrupt Input |
| GPB3<br>EXTINT23 | 11  | I/O16tsh | General Purpose I/O Function<br>External Interrupt Input |
| GPB2<br>EXTINT22 | 12  | I/O16tsh | General Purpose I/O Function<br>External Interrupt Input |
| GPB1<br>EXTINT21 | 13  | I/O16tsh | General Purpose I/O Function<br>External Interrupt Input |
| GPB0<br>EXTINT20 | 14  | I/O16tsh | General Purpose I/O Function<br>External Interrupt Input |
| GPA7<br>EXTINT17 | 15  | I/O16tsh | General Purpose I/O Function<br>External Interrupt Input |
| GPA6<br>EXTINT16 | 16  | I/O16tsh | General Purpose I/O Function<br>External Interrupt Input |
| GPA5<br>EXTINT15 | 17  | I/O16tsh | General Purpose I/O Function<br>External Interrupt Input |
| GPA4<br>EXTINT14 | 18  | I/O16tsh | General Purpose I/O Function<br>External Interrupt Input |
| GPA3<br>EXTINT13 | 19  | I/O16tsh | General Purpose I/O Function<br>External Interrupt Input |
| GPA2<br>EXTINT12 | 20  | I/O16tsh | General Purpose I/O Function<br>External Interrupt Input |
| GPA1<br>EXTINT11 | 21  | I/O16tsh | General Purpose I/O Function<br>External Interrupt Input |
| GPA0<br>EXTINT10 | 22  | I/O16tsh | General Purpose I/O Function<br>External Interrupt Input |
| VCC1             | 23  | Ivdd     | Normal Power Input, +3.3V                                |
| GP97             | 24  | I/O16tsh | General Purpose I/O Function                             |

# W83L951DG/W83L951FG



Pin configuration table, continued.

| SYMBOL           | PIN | I/O      | FUNCTION  |
|------------------|-----|----------|---|
| GP96             | 25  | I/O16tsh | General Purpose I/O Function  |
| GP95             | 26  | I/O16tsh | General Purpose I/O Function  |
| GP94             | 27  | I/O16tsh | General Purpose I/O Function  |
| GP93             | 28  | I/O16tsh | General Purpose I/O Function  |
| GP92             | 29  | I/O16tsh | General Purpose I/O Function  |
| GP91             | 30  | I/O16tsh | General Purpose I/O Function  |
| GP90             | 31  | I/O16tsh | General Purpose I/O Function  |
| GND              | 32  | Ivss     | Normal GND  |
| GP87             | 33  | I/O16tsh | General Purpose I/O Function  |
| GP86             | 34  | I/O16tsh | General Purpose I/O Function  |
| GP85             | 35  | I/O16tsh | General Purpose I/O Function  |
| GP84<br>CIR_RX   | 36  | I/O16tsh | General Purpose I/O Function<br>Consumer Infrared Communication Receiver Function |
| GP83<br>CNTR1    | 37  | I/O16tsh | General Purpose I/O Function<br>Timer Y Signal                                    |
| GP82<br>CNTR0    | 38  | I/O16tsh | General Purpose I/O Function<br>Timer X Signal                                    |
| GP81<br>SCL2     | 39  | I/O16tsh | General Purpose I/O Function<br>SMBus 2 Clock Signal                              |
| SYMBOL           | PIN | I/O      | FUNCTION  |
| GP80<br>SDA2     | 40  | I/O16tsh | General Purpose I/O Function<br>SMBus 2 Data Signal                               |
| GP77<br>SCL1     | 41  | I/O16tsh | General Purpose I/O Function<br>SMBus 1 Clock Signal                              |
| GP76<br>SDA1     | 42  | I/O16tsh | General Purpose I/O Function<br>SMBus 1 Data Signal                               |
| GP75<br>APS2_DAT | 43  | I/O16tsh | General Purpose I/O Function<br>Auxiliary PS2 Data Signal                         |
| GP74<br>APS2_CLK | 44  | I/O16tsh | General Purpose I/O Function<br>Auxiliary PS2 Clock Signal                        |
| GP73<br>MPS2_DAT | 45  | I/O16tsh | General Purpose I/O Function<br>Mouse PS2 Data Signal                             |

# W83L951DG/W83L951FG



Pin configuration table, continued.

| SYMBOL           | PIN | I/O             | FUNCTION   |
|------------------|-----|-----------------|--|
| GP72<br>MPS2_CLK | 46  | I/O16tsh        | General Purpose I/O Function<br>Mouse PS2 Clock Signal   |
| GP71<br>KPS2_DAT | 47  | I/O16tsh        | General Purpose I/O Function<br>Keyboard PS2 Data Signal   |
| GP70<br>KPS2_CLK | 48  | I/O16tsh        | General Purpose I/O Function<br>Keyboard PS2 Clock Signal  |
| VCC1             | 49  | Ivdd            | Normal Power Input, +3.3V  |
| RESET#           | 50  | I <sub>ts</sub> | System Reset.  |
| LCLK             | 51  | I <sub>ts</sub> | PCI clock input. Same 33MHz clock as PCI clock on the host.<br>Same clock phase with typical PCI skew. |
| LFRAME#          | 52  | I <sub>ts</sub> | Indicates start of a new cycle or termination of a broken cycle.                                       |
| LRESET#          | 53  | I <sub>ts</sub> | Reset signal. It can connect to PCIRST# signal on the host.  |
| SERIRQ           | 54  | I/O24ts         | Serial IRQ input/Output.   |
| GND              | 55  | Ivss            | Normal GND   |
| LAD0             | 56  | I/O24ts         | LAD[3..0] are multiplexed address, control, and data in LPC bus.                                       |
| LAD1             | 57  | I/O24ts         | LAD[3..0] are multiplexed address, control, and data in LPC bus.                                       |
| LAD2             | 58  | I/O24ts         | LAD[3..0] are multiplexed address, control, and data in LPC bus.                                       |
| LAD3             | 59  | I/O24ts         | LAD[3..0] are multiplexed address, control, and data in LPC bus.                                       |
| LPWRSTS          | 60  | I <sub>ts</sub> | Power status. Indicates current power status of LPC interface.   |
| GP47             | 61  | I/O16tsh        | General Purpose I/O Function   |
| GP46<br>CLKRUN#  | 62  | I/O16tsh        | General Purpose I/O Function<br>Advance LPC function: It is used to request starting the clock         |
| GP45<br>GATE_A20 | 63  | I/O16tsh        | General Purpose I/O Function<br>Gate A20 output  |
| GP44<br>KBRST#   | 64  | I/O16tsh        | General Purpose I/O Function<br>CPU reset output   |

# W83L951DG/W83L951FG



Pin configuration table, continued.

| SYMBOL               | PIN | I/O      | FUNCTION  |
|----------------------|-----|----------|---|
| GP43<br>TXD          | 65  | I/O16tsh | General Purpose I/O Function<br>UART TX output  |
| GP42<br>RXD          | 66  | I/O16tsh | General Purpose I/O Function<br>UART RX Input   |
| GP41<br>FAN_TACH1    | 67  | I/O16tsh | General Purpose I/O Function<br>Fan tachometer 1  |
| GP40<br>FAN_TACH0    | 68  | I/O16tsh | General Purpose I/O Function<br>Fan tachometer 0  |
| SYMBOL               | PIN | I/O      | FUNCTION  |
| GND                  | 69  | Ivss     | Normal GND  |
| GP27<br>PWM3         | 70  | I/O16tsh | General Purpose I/O Function<br>Pulse Width Modulator Output                            |
| GP26<br>PWM2         | 71  | I/O16tsh | General Purpose I/O Function<br>Pulse Width Modulator Output                            |
| GP25<br>PWM1         | 72  | I/O16tsh | General Purpose I/O Function<br>Pulse Width Modulator Output                            |
| GP24<br>PWM0         | 73  | I/O16tsh | General Purpose I/O Function<br>Pulse Width Modulator Output                            |
| GP23<br>KC19         | 74  | I/O12tsm | General Purpose I/O Function<br>Keyboard Matrix Column Output                           |
| GP22<br>KC18         | 75  | I/O12tsm | General Purpose I/O Function<br>Keyboard Matrix Column Output                           |
| GP21<br>KC17         | 76  | I/O12tsm | General Purpose I/O Function<br>Keyboard Matrix Column Output                           |
| GP20<br>KC16         | 77  | I/O12tsm | General Purpose I/O Function<br>Keyboard Matrix Column Output                           |
| VCC1                 | 78  | Ivdd     | Normal Power Input, +3.3V   |
| GP17<br>KC15<br>FA15 | 79  | I/O12tsm | General Purpose I/O Function<br>Keyboard Matrix Column Output<br>Internal Flash Address |

# W83L951DG/W83L951FG



Pin configuration table, continued.

| SYMBOL                 | PIN | I/O      | FUNCTION   |
|------------------------|-----|----------|--|
| GP16<br>KC14<br>FA14   | 80  | I/O12tsm | General Purpose I/O Function<br>Keyboard Matrix Column Output<br>Internal Flash Address                      |
| GP15<br>KC13<br>FA13   | 81  | I/O12tsm | General Purpose I/O Function<br>Keyboard Matrix Column Output<br>Internal Flash Address                      |
| GP14<br>KC12<br>FA12   | 82  | I/O12tsm | General Purpose I/O Function<br>Keyboard Matrix Column Output<br>Internal Flash Address                      |
| GP13<br>KC11<br>FA11   | 83  | I/O12tsm | General Purpose I/O Function<br>Keyboard Matrix Column Output<br>Internal Flash Address                      |
| GP12<br>KC10<br>FA10   | 84  | I/O12tsm | General Purpose I/O Function<br>Keyboard Matrix Column Output<br>Internal Flash Address                      |
| GP11<br>KC9<br>FA9     | 85  | I/O12tsm | General Purpose I/O Function<br>Keyboard Matrix Column Output<br>Internal Flash Address                      |
| GP10<br>KC8<br>FA8     | 86  | I/O12tsm | General Purpose I/O Function<br>Keyboard Matrix Column Output<br>Internal Flash Address                      |
| GP07<br>KC7<br>FA7/FD7 | 87  | I/O12tsm | General Purpose I/O Function<br>Keyboard Matrix Column Output<br>Internal Flash Address/ Internal Flash Data |
| GP06<br>KC6<br>FA6/FD6 | 88  | I/O12tsm | General Purpose I/O Function<br>Keyboard Matrix Column Output<br>Internal Flash Address/ Internal Flash Data |
| SYMBOL                 | PIN | I/O      | FUNCTION   |
| GP05<br>KC5<br>FA5/FD5 | 89  | I/O12tsm | General Purpose I/O Function<br>Keyboard Matrix Column Output<br>Internal Flash Address/ Internal Flash Data |



# W83L951DG/W83L951FG



Pin configuration table, continued.

| SYMBOL                 | PIN | I/O      | FUNCTION   |
|------------------------|-----|----------|--|
| GP04<br>KC4<br>FA4/FD4 | 90  | I/O12tsm | General Purpose I/O Function<br>Keyboard Matrix Column Output<br>Internal Flash Address/ Internal Flash Data           |
| GP03<br>KC3<br>FA3/FD3 | 91  | I/O12tsm | General Purpose I/O Function<br>Keyboard Matrix Column Output<br>Internal Flash Address/ Internal Flash Data           |
| GP02<br>KC2<br>FA2/FD2 | 92  | I/O12tsm | General Purpose I/O Function<br>Keyboard Matrix Column Output<br>Internal Flash Address/ Internal Flash Data           |
| GP01<br>KC1<br>FA1/FD1 | 93  | I/O12tsm | General Purpose I/O Function<br>Keyboard Matrix Column Output<br>Internal Flash Address/ Internal Flash Data           |
| GP00<br>KC0<br>FA0/FD0 | 94  | I/O12tsm | General Purpose I/O Function<br>Keyboard Matrix Column Output<br>Internal Flash Address/ Internal Flash Data           |
| GP37<br>KR7<br>CE#     | 95  | I/O16tsh | General Purpose I/O Function<br>Keyboard Matrix Row Input<br>Internal Flash Access Interface: Flash chip select enable |
| GP36<br>KR6<br>OE#     | 96  | I/O16tsh | General Purpose I/O Function<br>Keyboard Matrix Row Input<br>Internal Flash Access Interface: Flash output enable      |
| GP35<br>KR5<br>WE#     | 97  | I/O16tsh | General Purpose I/O Function<br>Keyboard Matrix Row Input<br>Internal Flash Access Interface: Flash write enable       |
| GP34<br>KR4<br>ALE     | 98  | I/O16tsh | General Purpose I/O Function<br>Keyboard Matrix Row Input<br>Internal Flash Access Interface: Address latch enable     |
| GP33<br>KR3            | 99  | I/O16tsh | General Purpose I/O Function<br>Keyboard Matrix Row Input  |
| GP32<br>KR2            | 100 | I/O16tsh | General Purpose I/O Function<br>Keyboard Matrix Row Input  |

# W83L951DG/W83L951FG



Pin configuration table, continued.

| SYMBOL      | PIN | I/O       | FUNCTION   |
|-------------|-----|-----------|--|
| GP31<br>KR1 | 101 | I/O16tsh  | General Purpose I/O Function<br>Keyboard Matrix Row Input  |
| GP30<br>KR0 | 102 | I/O16tsh  | General Purpose I/O Function<br>Keyboard Matrix Row Input  |
| VREF        | 103 | Ivdd      | Analog Reference Voltage Input                             |
| GP67<br>AD7 | 104 | I/O12tsao | General Purpose I/O Function<br>A/D Converter Input Signal |
| GP66<br>AD6 | 105 | I/O12tsao | General Purpose I/O Function<br>A/D Converter Input Signal |
| GP65<br>AD5 | 106 | I/O12tsao | General Purpose I/O Function<br>A/D Converter Input Signal |
| GP64<br>AD4 | 107 | I/O12tsao | General Purpose I/O Function<br>A/D Converter Input Signal |
| SYMBOL      | PIN | I/O       | FUNCTION   |
| GP63<br>AD3 | 108 | I/O12tsao | General Purpose I/O Function<br>A/D Converter Input Signal |
| GP62<br>AD2 | 109 | I/O12tsao | General Purpose I/O Function<br>A/D Converter Input Signal |
| GP61<br>AD1 | 110 | I/O12tsao | General Purpose I/O Function<br>A/D Converter Input Signal |
| GP60<br>AD0 | 111 | I/O12tsao | General Purpose I/O Function<br>A/D Converter Input Signal |
| AVCC        | 112 | Ivdd      | Analog Power Input, +3.3V                                  |
| GP57<br>DA2 | 113 | I/O12tsai | General Purpose I/O Function<br>DA Converter Output        |
| GP56<br>DA1 | 114 | I/O12tsai | General Purpose I/O Function<br>DA Converter Output        |
| AGND        | 115 | Ivss      | Analog GND   |
| GP55        | 116 | I/O16tsh  | General Purpose I/O Function                               |
| GP54        | 117 | I/O16tsh  | General Purpose I/O Function                               |
| GP53        | 118 | I/O16tsh  | General Purpose I/O Function                               |
| GP52        | 119 | I/O16tsh  | General Purpose I/O Function                               |

# W83L951DG/W83L951FG



Pin configuration table, continued.

| SYMBOL           | PIN | I/O             | FUNCTION   |
|------------------|-----|-----------------|--|
| GP51             | 120 | I/O16tsh        | General Purpose I/O Function                             |
| GP50             | 121 | I/O16tsh        | General Purpose I/O Function                             |
| XOUT             | 122 | Oc              | 24MHz/12MHz System Clock Output                          |
| XIN              | 123 | Ic              | 24MHz/12MHz System Clock Input                           |
| TEST#            | 124 | I <sub>ts</sub> | Test pin to provide different operation.                 |
| XCOUT            | 125 | Oc              | 32.768 KHz Clock Output                                  |
| XCIN             | 126 | Ic              | 32.768 KHz Clock Input                                   |
| GPC7<br>EXTINT37 | 127 | I/O16tsh        | General Purpose I/O Function<br>External Interrupt Input |
| GPC6<br>EXTINT36 | 128 | I/O16tsh        | General Purpose I/O Function<br>External Interrupt Input |

## 5.2 RESET# & TEST# Part

Table 5-3 RESET# & TEST# pin configuration table

| SYMBOL | PIN | I/O             | FUNCTION                                 |
|--------|-----|-----------------|--|
| RESET# | 50  | I <sub>ts</sub> | System Reset.                            |
| TEST#  | 124 | I <sub>ts</sub> | Test pin to provide different operation. |

In W83L951DG/FG, RESET# Pin and TEST# Pin decide the status of W83L951DG/FG to provide 4 operations.

| TEST# | RESET# | CHIP CURRENT STATUS                    |
|-------|--------|--|
| 0     | 0      | Internal Flash Access Interface Enable |
| 0     | 1      | Reserved                               |
| 1     | 0      | Normal Reset                           |
| 1     | 1      | Normal Operation                       |



## 5.3 LPC Interface Part

LPC Interface is formed by LAD0~LAD3, SERIRQ, LRESET#, LFRAME#, LCLK and VCC2. These pins are defined by LPC interface Spec except VCC2. Below are descriptions about all LPC pins:

Table 5-4 LPC interface pin configuration table

| SYMBOL  | PIN | I/O                 | FUNCTION  |
|---------|-----|---------------------|---|
| LCLK    | 51  | I <sub>ts</sub>     | PCI clock input. Same 33MHz clock as PCI clock on the host. Same clock phase with typical PCI skew. |
| LFRAME# | 52  | I <sub>ts</sub>     | Indicates start of a new cycle or termination of a broken cycle.                                    |
| LRESET# | 53  | I <sub>ts</sub>     | Reset signal. It can connect to PCIRST# signal on the host.   |
| SERIRQ  | 54  | I/O <sub>24ts</sub> | Serial IRQ input/Output.  |
| LAD0    | 56  | I/O <sub>24ts</sub> | LAD[3..0] are multiplexed address, control, and data in LPC bus.                                    |
| LAD1    | 57  | I/O <sub>24ts</sub> | LAD[3..0] are multiplexed address, control, and data in LPC bus.                                    |
| LAD2    | 58  | I/O <sub>24ts</sub> | LAD[3..0] are multiplexed address, control, and data in LPC bus.                                    |
| LAD3    | 59  | I/O <sub>24ts</sub> | LAD[3..0] are multiplexed address, control, and data in LPC bus.                                    |

**Note:** Other pins about LPC interface, CLKRUN#: Please see "GP4" part. VCC2: Please see "power & clock" part.

## 5.4 GPIO0 Part

This part contains:

### General Purpose I/O Function

Default is General Purpose I/O. Change the value of GPIO0 and GPIOD0 register to determine 8 input/output.

### Keyboard Matrix Column Output

Use Chipctrl2 register bit 3 to enable {GP0, GP1, GP20~23} keyboard scan and GP3 key wakeup interrupt function.

### Internal Flash Access Interface

When TEST# and RESET# are both low, Internal Flash Access Interface is enabled and other functions are disabled.



Table 5-5 GPIO0 pin configuration table

| SYMBOL                 | PIN | I/O                  | FUNCTION   |
|------------------------|-----|----------------------|--|
| GP07<br>KC7<br>FA7/FD7 | 87  | I/O <sub>12tsm</sub> | General Purpose I/O Function<br>Keyboard Matrix Column Output<br>Internal Flash Address/ Internal Flash Data |
| GP06<br>KC6<br>FA6/FD6 | 88  | I/O <sub>12tsm</sub> | General Purpose I/O Function<br>Keyboard Matrix Column Output<br>Internal Flash Address/ Internal Flash Data |
| GP05<br>KC5<br>FA5/FD5 | 89  | I/O <sub>12tsm</sub> | General Purpose I/O Function<br>Keyboard Matrix Column Output<br>Internal Flash Address/ Internal Flash Data |
| GP04<br>KC4<br>FA4/FD4 | 90  | I/O <sub>12tsm</sub> | General Purpose I/O Function<br>Keyboard Matrix Column Output<br>Internal Flash Address/ Internal Flash Data |
| GP03<br>KC3<br>FA3/FD3 | 91  | I/O <sub>12tsm</sub> | General Purpose I/O Function<br>Keyboard Matrix Column Output<br>Internal Flash Address/ Internal Flash Data |
| GP02<br>KC2<br>FA2/FD2 | 92  | I/O <sub>12tsm</sub> | General Purpose I/O Function<br>Keyboard Matrix Column Output<br>Internal Flash Address/ Internal Flash Data |
| GP01<br>KC1<br>FA1/FD1 | 93  | I/O <sub>12tsm</sub> | General Purpose I/O Function<br>Keyboard Matrix Column Output<br>Internal Flash Address/ Internal Flash Data |
| GP00<br>KC0<br>FA0/FD0 | 94  | I/O <sub>12tsm</sub> | General Purpose I/O Function<br>Keyboard Matrix Column Output<br>Internal Flash Address/ Internal Flash Data |



## 5.5 GPIO1 Part

This part contains:

### General Purpose I/O Function

Default is General Purpose I/O. Change the value of GPIO1 and GPIOD1 register to determine 8 input/output.

### Keyboard Matrix Column Output

Use Chipctrl2 register bit 3 to enable {GP0, GP1, GP20~23} keyboard scan and GP3 key wakeup interrupt function.

### Internal Flash Access Interface

When TEST# and RESET# are both low, Internal Flash Access Interface is enabled and other functions are disabled.

Table 5-6 GPIO1 pin configuration table

| SYMBOL               | PIN | I/O                  | FUNCTION  |
|----------------------|-----|----------------------|---|
| GP17<br>KC15<br>FA15 | 79  | I/O <sub>12tsm</sub> | General Purpose I/O Function<br>Keyboard Matrix Column Output<br>Internal Flash Address |
| GP16<br>KC14<br>FA14 | 80  | I/O <sub>12tsm</sub> | General Purpose I/O Function<br>Keyboard Matrix Column Output<br>Internal Flash Address |
| GP15<br>KC13<br>FA13 | 81  | I/O <sub>12tsm</sub> | General Purpose I/O Function<br>Keyboard Matrix Column Output<br>Internal Flash Address |
| GP14<br>KC12<br>FA12 | 82  | I/O <sub>12tsm</sub> | General Purpose I/O Function<br>Keyboard Matrix Column Output<br>Internal Flash Address |
| GP13<br>KC11<br>FA11 | 83  | I/O <sub>12tsm</sub> | General Purpose I/O Function<br>Keyboard Matrix Column Output<br>Internal Flash Address |
| GP12<br>KC10<br>FA10 | 84  | I/O <sub>12tsm</sub> | General Purpose I/O Function<br>Keyboard Matrix Column Output<br>Internal Flash Address |
| GP11<br>KC9<br>FA9   | 85  | I/O <sub>12tsm</sub> | General Purpose I/O Function<br>Keyboard Matrix Column Output<br>Internal Flash Address |
| GP10<br>KC8<br>FA8   | 86  | I/O <sub>12tsm</sub> | General Purpose I/O Function<br>Keyboard Matrix Column Output<br>Internal Flash Address |



## 5.6 GPIO2 Part

This part contains:

### General Purpose I/O Function

Default is General Purpose I/O. Change the value of GPIO2 and GPIOD2 register to determine 8 input/output.

### Pulse Width Modulator Output

Use Pulse Width Modulator Registers to control 4 Pulse Width Modulator Output.

### Keyboard Matrix Column Output

Change the value of chip control 2 register bit 3 (Keyboard Scan Function Enable) to enable {GP0, GP1, GP20~23} keyboard scan function and GP3 key wakeup interrupt function.

Table 5-7 GPIO2 pin configuration table

| SYMBOL       | PIN | I/O                  | FUNCTION  |
|--------------|-----|----------------------|---|
| GP27<br>PWM3 | 70  | I/O <sub>16tsh</sub> | General Purpose I/O Function<br>Pulse Width Modulator Output  |
| GP26<br>PWM2 | 71  | I/O <sub>16tsh</sub> | General Purpose I/O Function<br>Pulse Width Modulator Output  |
| GP25<br>PWM1 | 72  | I/O <sub>16tsh</sub> | General Purpose I/O Function<br>Pulse Width Modulator Output  |
| GP24<br>PWM0 | 73  | I/O <sub>16tsh</sub> | General Purpose I/O Function<br>Pulse Width Modulator Output  |
| GP23<br>KC19 | 74  | I/O <sub>12tsm</sub> | General Purpose I/O Function<br>Keyboard Matrix Column Output |
| GP22<br>KC18 | 75  | I/O <sub>12tsm</sub> | General Purpose I/O Function<br>Keyboard Matrix Column Output |
| GP21<br>KC17 | 76  | I/O <sub>12tsm</sub> | General Purpose I/O Function<br>Keyboard Matrix Column Output |
| GP20<br>KC16 | 77  | I/O <sub>12tsm</sub> | General Purpose I/O Function<br>Keyboard Matrix Column Output |



## 5.7 GPIO3 Part

This part contains General Purpose I/O function, external flash interface, and keyboard matrix row input. Default function is General Purpose I/O function.

### General Purpose I/O Function

Change the value of GPIO 3 data register (GPIO3) and GPIO 3 direction register (GPIOD3) to determine 8 input/output.

### Keyboard Matrix Row Input

Change the value of chip control 2 register bit 3 (Keyboard Scan Function Enable) to enable GP3 key wakeup interrupt function.

Note: GPIO3 must be set as input when this function is enabled

The sample frequency about KEY Interrupt Mode is a system cycle, trigger for ' Low ' of input of GP3 and only take a sample once (unless input of GP3 return 'High', then enter 'low'). If signal debounce, then interrupt may request again.

### Internal Flash Access Interface

GPIO30~33: Reserved (Must assign low)

Table 5-8 GPIO3 pin configuration table

| SYMBOL             | PIN | I/O                  | FUNCTION   |
|--------------------|-----|----------------------|--|
| GP37<br>KR7<br>CE# | 95  | I/O <sub>16tsh</sub> | General Purpose I/O Function<br>Keyboard Matrix Row Input<br>Internal Flash Access Interface: Flash chip select enable |
| GP36<br>KR6<br>OE# | 96  | I/O <sub>16tsh</sub> | General Purpose I/O Function<br>Keyboard Matrix Row Input<br>Internal Flash Access Interface: Flash output enable      |
| GP35<br>KR5<br>WE# | 97  | I/O <sub>16tsh</sub> | General Purpose I/O Function<br>Keyboard Matrix Row Input<br>Internal Flash Access Interface: Flash write enable       |
| GP34<br>KR4<br>ALE | 98  | I/O <sub>16tsh</sub> | General Purpose I/O Function<br>Keyboard Matrix Row Input<br>Internal Flash Access Interface: Address latch enable     |
| GP33<br>KR3        | 99  | I/O <sub>16tsh</sub> | General Purpose I/O Function<br>Keyboard Matrix Row Input  |
| GP32<br>KR2        | 100 | I/O <sub>16tsh</sub> | General Purpose I/O Function<br>Keyboard Matrix Row Input  |
| GP31<br>KR1        | 101 | I/O <sub>16tsh</sub> | General Purpose I/O Function<br>Keyboard Matrix Row Input  |
| GP30<br>KR0        | 102 | I/O <sub>16tsh</sub> | General Purpose I/O Function<br>Keyboard Matrix Row Input  |





## 5.8 GPIO4 Part

### General Purpose I/O Function

Change the value of GPIO 4 data register (GPIO4) and GPIO 4 direction register (GPIOD4) to determine 8 input/output.

### Universal Asynchronous Serial I/O Function

Change the value of chip control 1 register bit 3 (UART Function Enable) to enable Universal Asynchronous Serial I/O Function.

### Hardware Keyboard Reset Function

Change the value of keyboard control register bit4 (Port 92 Enable) and bit3 (Hardware Keyboard Reset Control Enable) to enable Hardware Keyboard Reset Function.

### Hardware Gate A20 Function

Change the value of keyboard control register bit4 (Port 92 Enable) and bit2 (Hardware Gate A20 Control Enable) to enable Hardware Gate A20 Function.

Table 5-9 GPIO4 pin configuration table

| SYMBOL            | PIN | I/O                  | FUNCTION   |
|-------------------|-----|----------------------|--|
| GP47              | 61  | I/O <sub>16tsh</sub> | General Purpose I/O Function   |
| GP46<br>CLKRUN#   | 62  | I/O <sub>16tsh</sub> | General Purpose I/O Function<br>Advance LPC function: It is used to request starting the clock |
| GP45<br>GATE_A20  | 63  | I/O <sub>16tsh</sub> | General Purpose I/O Function<br>Gate A20 output  |
| GP44<br>KBRST#    | 64  | I/O <sub>16tsh</sub> | General Purpose I/O Function<br>CPU reset output   |
| GP43<br>TXD       | 65  | I/O <sub>16tsh</sub> | General Purpose I/O Function<br>UART TX output   |
| GP42<br>RXD       | 66  | I/O <sub>16tsh</sub> | General Purpose I/O Function<br>UART RX Input  |
| GP41<br>FAN_TACH1 | 67  | I/O <sub>16tsh</sub> | General Purpose I/O Function<br>Fan tachometer 1   |
| GP40<br>FAN_TACH0 | 68  | I/O <sub>16tsh</sub> | General Purpose I/O Function<br>Fan tachometer 0   |



## 5.9 GPIO5 Part

### General Purpose I/O Function

Change the value of GPIO 5 data register (GPIO5) and GPIO 5 direction register (GPIOD3) to determine 8 input/output.

### D/A Converter Function

Change the value of chip control 2 register bit 7 (D/A 2 Function Enable) and Bit 6 (D/A 1 Function Enable) to enable D/A Converter Function.

Table 5-10 GPIO5 pin configuration table

| SYMBOL      | PIN | I/O                   | FUNCTION   |
|-------------|-----|-----------------------|--|
| GP57<br>DA2 | 113 | I/O <sub>12tsai</sub> | General Purpose I/O Function<br>DA2 Converter Output |
| GP56<br>DA1 | 114 | I/O <sub>12tsai</sub> | General Purpose I/O Function<br>DA1 Converter Output |
| GP55        | 116 | I/O <sub>16tsh</sub>  | General Purpose I/O Function                         |
| GP54        | 117 | I/O <sub>16tsh</sub>  | General Purpose I/O Function                         |
| GP53        | 118 | I/O <sub>16tsh</sub>  | General Purpose I/O Function                         |
| GP52        | 119 | I/O <sub>16tsh</sub>  | General Purpose I/O Function                         |
| GP51        | 120 | I/O <sub>16tsh</sub>  | General Purpose I/O Function                         |
| GP50        | 121 | I/O <sub>16tsh</sub>  | General Purpose I/O Function                         |

## 5.10 GPIO6 Part

### General Purpose I/O Function

Change the value of GPIO 6 data register (GPIO6) and GPIO 6 direction register (GPIOD6) to determine 8 input/output.

### A/D Converter Function

Change the value of chip control 2 register bit 5 (A/D Function Enable) to enable A/D Converter Function.



Table 5-11 GPIO6 pin configuration table

| SYMBOL      | PIN | I/O                   | FUNCTION   |
|-------------|-----|-----------------------|--|
| GP67<br>AD7 | 104 | I/O <sub>12tsao</sub> | General Purpose I/O Function<br>A/D Converter Input Signal |
| GP66<br>AD6 | 105 | I/O <sub>12tsao</sub> | General Purpose I/O Function<br>A/D Converter Input Signal |
| GP65<br>AD5 | 106 | I/O <sub>12tsao</sub> | General Purpose I/O Function<br>A/D Converter Input Signal |
| GP64<br>AD4 | 107 | I/O <sub>12tsao</sub> | General Purpose I/O Function<br>A/D Converter Input Signal |
| GP63<br>AD3 | 108 | I/O <sub>12tsao</sub> | General Purpose I/O Function<br>A/D Converter Input Signal |
| GP62<br>AD2 | 109 | I/O <sub>12tsao</sub> | General Purpose I/O Function<br>A/D Converter Input Signal |
| GP61<br>AD1 | 110 | I/O <sub>12tsao</sub> | General Purpose I/O Function<br>A/D Converter Input Signal |
| GP60<br>AD0 | 111 | I/O <sub>12tsao</sub> | General Purpose I/O Function<br>A/D Converter Input Signal |

## 5.11 GPIO7 Part

### General Purpose I/O Function

Change the value of GPIO 7 data register (GPIO7) and GPIO 7 direction register (GPIOD7) to determine 8 input/output.

### Keyboard PS2 Function Enable Function

Change the value of chip control 3 register bit 2 (Keyboard PS2 Function Enable) to enable Keyboard PS2 Function Enable Function.

### Mouse PS2 Function Enable Function

Change the value of chip control 3 register bit 3 (Mouse PS2 Function Enable) to enable Mouse PS2 Function Enable Function.

### Auxiliary PS2 Function Enable Function

Change the value of chip control 3 register bit 4 (Auxiliary PS2 Function Enable) to enable Auxiliary PS2 Function Enable Function.

### SMBUS 1 Function

Change the value of chip control 3 register bit 0 (SMBUS 1 Function Enable) to enable SMBUS 1 Function.



Table 5-12 GPIO7 pin configuration table

| SYMBOL           | PIN | I/O                  | FUNCTION   |
|------------------|-----|----------------------|--|
| GP77<br>SCL1     | 41  | I/O <sub>16tsh</sub> | General Purpose I/O Function<br>SMBus 1 Clock Signal       |
| GP76<br>SDA1     | 42  | I/O <sub>16tsh</sub> | General Purpose I/O Function<br>SMBus 1 Data Signal        |
| GP75<br>APS2_DAT | 43  | I/O <sub>16tsh</sub> | General Purpose I/O Function<br>Auxiliary PS2 Data Signal  |
| GP74<br>APS2_CLK | 44  | I/O <sub>16tsh</sub> | General Purpose I/O Function<br>Auxiliary PS2 Clock Signal |
| GP73<br>MPS2_DAT | 45  | I/O <sub>16tsh</sub> | General Purpose I/O Function<br>Mouse PS2 Data Signal      |
| GP72<br>MPS2_CLK | 46  | I/O <sub>16tsh</sub> | General Purpose I/O Function<br>Mouse PS2 Clock Signal     |
| GP71<br>KPS2_DAT | 47  | I/O <sub>16tsh</sub> | General Purpose I/O Function<br>Keyboard PS2 Data Signal   |
| GP70<br>KPS2_CLK | 48  | I/O <sub>16tsh</sub> | General Purpose I/O Function<br>Keyboard PS2 Clock Signal  |

## 5.12 GPIO8 Part

### General Purpose I/O Function

Change the value of GPIO 8 data register (GPIO8) and GPIO 8 direction register (GPIOD8) to determine 8 input/output.

### Consumer Infrared Communications Receiver Function

Change the value of chip control 3 register bit 5 (CIR Function Enable) to enable Consumer Infrared Communications Receiver Function.

### Wave Measurement Function

Change the value of timer X/Y mode register bit 5-4 and bit 1-0 to enable Wave Measurement Function.

### SMBUS 2 Function

Change the value of chip control 2 register bit 1 (SMBUS 2 Function Enable) to enable SMBUS 2 Function.



Table 5-13 GPIO8 pin configuration table

| SYMBOL         | PIN | I/O                  | FUNCTION  |
|----------------|-----|----------------------|---|
| GP87           | 33  | I/O <sub>16tsh</sub> | General Purpose I/O Function  |
| GP86           | 34  | I/O <sub>16tsh</sub> | General Purpose I/O Function  |
| GP85           | 35  | I/O <sub>16tsh</sub> | General Purpose I/O Function  |
| GP84<br>CIR_RX | 36  | I/O <sub>16tsh</sub> | General Purpose I/O Function<br>Consumer Infrared Communication Receiver Function |
| GP83<br>CNTR1  | 37  | I/O <sub>16tsh</sub> | General Purpose I/O Function<br>Timer Y Signal                                    |
| GP82<br>CNTR0  | 38  | I/O <sub>16tsh</sub> | General Purpose I/O Function<br>Timer X Signal                                    |
| GP81<br>SCL2   | 39  | I/O <sub>16tsh</sub> | General Purpose I/O Function<br>SMBus 2 Clock Signal                              |
| GP80<br>SDA2   | 40  | I/O <sub>16tsh</sub> | General Purpose I/O Function<br>SMBus 2 Data Signal                               |

## 5.13 GPIO9 Part

### General Purpose I/O Function

Change the value of GPIO 9 data register (GPIO9) and GPIO 9 direction register (GPIOD9) to determine 8 input/output.

Table 5-14 GPIO9 pin configuration table

| SYMBOL | PIN | I/O                  | FUNCTION                     |
|--------|-----|----------------------|------------------------------|
| GP97   | 24  | I/O <sub>16tsh</sub> | General Purpose I/O Function |
| GP96   | 25  | I/O <sub>16tsh</sub> | General Purpose I/O Function |
| GP95   | 26  | I/O <sub>16tsh</sub> | General Purpose I/O Function |
| GP94   | 27  | I/O <sub>16tsh</sub> | General Purpose I/O Function |
| GP93   | 28  | I/O <sub>16tsh</sub> | General Purpose I/O Function |
| GP92   | 29  | I/O <sub>16tsh</sub> | General Purpose I/O Function |
| GP91   | 30  | I/O <sub>16tsh</sub> | General Purpose I/O Function |
| GP90   | 31  | I/O <sub>16tsh</sub> | General Purpose I/O Function |



## 5.14 GPIOA Part

### General Purpose I/O Function

Change the value of GPIO A data register (GPIOA) and GPIO A direction register (GPIODA) to determine 8 input/output.

### External Interrupt Source Input Function

Change the value of external interrupt enable 1 register to determine External Interrupt.

Table 5-15 GPIOA pin configuration table

| SYMBOL           | PIN | I/O                  | FUNCTION   |
|------------------|-----|----------------------|--|
| GPA7<br>EXTINT17 | 15  | I/O <sub>16tsh</sub> | General Purpose I/O Function<br>External Interrupt Input |
| GPA6<br>EXTINT16 | 16  | I/O <sub>16tsh</sub> | General Purpose I/O Function<br>External Interrupt Input |
| GPA5<br>EXTINT15 | 17  | I/O <sub>16tsh</sub> | General Purpose I/O Function<br>External Interrupt Input |
| GPA4<br>EXTINT14 | 18  | I/O <sub>16tsh</sub> | General Purpose I/O Function<br>External Interrupt Input |
| GPA3<br>EXTINT13 | 19  | I/O <sub>16tsh</sub> | General Purpose I/O Function<br>External Interrupt Input |
| GPA2<br>EXTINT12 | 20  | I/O <sub>16tsh</sub> | General Purpose I/O Function<br>External Interrupt Input |
| GPA1<br>EXTINT11 | 21  | I/O <sub>16tsh</sub> | General Purpose I/O Function<br>External Interrupt Input |
| GPA0<br>EXTINT10 | 22  | I/O <sub>16tsh</sub> | General Purpose I/O Function<br>External Interrupt Input |

## 5.15 GPIOB Part

### General Purpose I/O Function

Change the value of GPIO B data register (GPIOB) and GPIO B direction register (GPIODB) to determine 8 input/output.

### External Interrupt Source Input Function

Change the value of external interrupt enable 2 register to determine External Interrupt.



Table 5-16 GPIOB pin configuration table

| SYMBOL           | PIN | I/O                  | FUNCTION   |
|------------------|-----|----------------------|--|
| GPB7<br>EXTINT27 | 7   | I/O <sub>16tsh</sub> | General Purpose I/O Function<br>External Interrupt Input |
| GPB6<br>EXTINT26 | 8   | I/O <sub>16tsh</sub> | General Purpose I/O Function<br>External Interrupt Input |
| GPB5<br>EXTINT25 | 9   | I/O <sub>16tsh</sub> | General Purpose I/O Function<br>External Interrupt Input |
| GPB4<br>EXTINT24 | 10  | I/O <sub>16tsh</sub> | General Purpose I/O Function<br>External Interrupt Input |
| GPB3<br>EXTINT23 | 11  | I/O <sub>16tsh</sub> | General Purpose I/O Function<br>External Interrupt Input |
| GPB2<br>EXTINT22 | 12  | I/O <sub>16tsh</sub> | General Purpose I/O Function<br>External Interrupt Input |
| GPB1<br>EXTINT21 | 13  | I/O <sub>16tsh</sub> | General Purpose I/O Function<br>External Interrupt Input |
| GPB0<br>EXTINT20 | 14  | I/O <sub>16tsh</sub> | General Purpose I/O Function<br>External Interrupt Input |

## 5.16 GPIOC Part

### General Purpose I/O Function

Change the value of GPIO C data register (GPIOC) and GPIO C direction register (GPIODC) to determine 8 input/output.

### External Interrupt Source Input Function

Change the value of external interrupt enable 3 register to determine External Interrupt.



Table 5-17 GPIOC pin configuration table

| SYMBOL           | PIN | I/O                  | FUNCTION   |
|------------------|-----|----------------------|--|
| GPC7<br>EXTINT37 | 127 | I/O <sub>16tsh</sub> | General Purpose I/O Function<br>External Interrupt Input |
| GPC6<br>EXTINT36 | 128 | I/O <sub>16tsh</sub> | General Purpose I/O Function<br>External Interrupt Input |
| GPC5<br>EXTINT35 | 1   | I/O <sub>16tsh</sub> | General Purpose I/O Function<br>External Interrupt Input |
| GPC4<br>EXTINT34 | 2   | I/O <sub>16tsh</sub> | General Purpose I/O Function<br>External Interrupt Input |
| GPC3<br>EXTINT33 | 3   | I/O <sub>16tsh</sub> | General Purpose I/O Function<br>External Interrupt Input |
| GPC2<br>EXTINT32 | 4   | I/O <sub>16tsh</sub> | General Purpose I/O Function<br>External Interrupt Input |
| GPC1<br>EXTINT31 | 5   | I/O <sub>16tsh</sub> | General Purpose I/O Function<br>External Interrupt Input |
| GPC0<br>EXTINT30 | 6   | I/O <sub>16tsh</sub> | General Purpose I/O Function<br>External Interrupt Input |

## 5.17 Power & Clock Part

Table 5-18 Power & clock pin configuration table

| SYMBOL | PIN | I/O              | FUNCTION   |
|--------|-----|------------------|--|
| XOUT   | 122 | O <sub>c</sub>   | 24MHz/12MHz System Clock Output                                |
| XIN    | 123 | I <sub>c</sub>   | 24MHz/12MHz System Clock Input                                 |
| XCOUT  | 125 | O <sub>c</sub>   | 32.768 KHz Clock Output  |
| XCIN   | 126 | I <sub>c</sub>   | 32.768 KHz Clock Input   |
| VCC1   | 23  | I <sub>vdd</sub> | Normal Power Input, +3.3V                                      |
|        | 49  |                  |  |
|        | 78  |                  |  |
| VCC2   | 60  | I <sub>ts</sub>  | Power status. Indicates current power status of LPC interface. |
| GND    | 32  | I <sub>vss</sub> | Normal GND   |
|        | 55  |                  |  |
|        | 69  |                  |  |
| AVCC   | 112 | I <sub>vdd</sub> | Analog Power Input, +3.3V                                      |
| AGND   | 115 | I <sub>vss</sub> | Analog GND   |
| VREF   | 103 | I <sub>vdd</sub> | Analog Reference Voltage Input                                 |





## 6. FUNCTIONAL DESCRIPTION

In W83L951DG/FG, memory organization and data type are based on Turbo 51 core controller. Register sets of various function blocks are finished by accessing Special Function Register (SFR).

According to the difference of accessing approaches, SFR are divided into Address Mapping and External RAM Address Mapping.

### Internal RAM Address Mapping:

It means to use direct addressing to access 128 bytes from internal RAM address 80H to 0FFH. Function blocks that use Internal RAM Address Mapping are listed below:

Table 6-1 Reset Source Table

| NAME                               | RESET SOURCE                              |
|------------------------------------|---|
| 8051 Core                          | System Reset.                             |
| Internal Interrupt Controller      | System Reset                              |
| PS2 Device Interface               | System Reset + PS2 Reset                  |
| Low Pin Count Interface Controller | System Reset + LPC Power Fail + LPC Reset |
| SMBus 1                            | System Reset + SMBUS1 Reset               |
| SMBus 2                            | System Reset + SMBUS2Reset                |
| GPIO Controller                    | System Reset.                             |

Table 6-2 Internal RAM Address Mapping Table

| Base on 00h | Index |            |           |           |           |            |          |         |
|-------------|-------|------------|-----------|-----------|-----------|------------|----------|---------|
| Offset      | 0     | 1          | 2         | 3         | 4         | 5          | 6        | 7       |
| 80          | +GP0  | SP         | DPL1      | DPH1      | DPL2      | DPH2       | ID       | VERSION |
| 88          | +GP1  | CHIPCTRL1  | CHIPCTRL2 | CHIPCTRL3 | DPSEL     | INTEN      | MMEN     |         |
| 90          | +GP2  | KBCCON     | LPCCON    | DBB0STS   | DBB0      | DBB0ADDH   | DBB0ADDL | SIRQ0   |
| 98          | +GP3  | DBB1STS    | DBB1      | DBB1ADDH  | DBB1ADDL  | SIRQ1      |          |         |
| A0          | +GP4  | KPS2DATA   | KPS2CON   | KPS2STS   | MPS2DATA  | MPS2CON    | MPS2STS  | PS2HSEN |
| A8          | +GP5  | APS2DATA   | APS2CON   | APS2STS   |           |            |          |         |
| B0          | +GP6  | S1CR       | S1IREQ    | S1IE      | S1FIFOCON | S1MFIFO    | S1MCON   | S1MSTS  |
| B8          | +GP7  | S1MFIFOSTS | S1SFIFO   | S1SCON    | S1SSTS    | S1SFIFOSTS |          |         |
| C0          | +GP8  | S2CR       | S2IREQ    | S2IE      | S2FIFOCON | S2MFIFO    | S2MCON   | S2MSTS  |
| C8          | +GP9  | S2MFIFOSTS | S2SFIFO   | S2SCON    | S2SSTS    | S2SFIFOSTS |          |         |
| D0          | +PSW  | GPD0       | GPD1      | GPD2      | GPD3      | GPD4       | GPD5     | GPD6    |
| D8          | +GPA  | GPD7       | GPD8      | GPD9      | GPDA      | GPDB       | GPDC     |         |
| E0          | +ACC  | IE1        | IE2       | IE3       | IE4       |            |          |         |
| E8          | +GPB  | IREQ1      | IREQ2     | IREQ3     | IREQ4     |            |          |         |
| F0          | +B    | IP1        | IP2       | IP3       | IP4       |            |          |         |
| F8          | +GPC  | FCON       | FADDH     | FADDL     | FDATA     |            |          |         |
| Index + 8   | 8     | 9          | A         | B         | C         |            | E        | F       |

Read Only

Reserved

a bit addressable register

# W83L951DG/W83L951FG



## External RAM Address Mapping:

It means to use MOVX to access 256 bytes from external RAM addressing FF00H~FFFFH.

Function blocks that use External RAM Address Mapping are listed below:

Table 6-3 Reset Source Table

| NAME                     | RESET SOURCE                    |
|--------------------------|---------------------------------|
| Watch Dog Block          | System Reset + WDT Reset        |
| Timer Block              | System Reset                    |
| PWM1/2/3/4 Block         | System Reset + PWM1/2/3/4 Reset |
| Serial I/O Block         | System Reset + SIO Reset        |
| CIR Block                | System Reset + CIR Reset        |
| AD Convert Block         | System Reset + AD Reset         |
| DA Convert Block         | System Reset + DA Reset         |
| External Interrupt Block | System Reset + System Reset.    |
| FAN Block                | System Reset + FAN Reset        |
| RTC Block                | System Reset + RTC Reset        |

Table 6-4 External RAM Address Mapping Table

| Base<br>FF00h | Index   |          |         |          |         |         |        |        |
|---------------|---------|----------|---------|----------|---------|---------|--------|--------|
|               | 0       | 1        | 2       | 3        | 4       | 5       | 6      | 7      |
| 00h           | WDTCN   | WDTSTS   |         |          |         |         |        |        |
| 08h           |         |          |         |          |         |         |        |        |
| 10h           | PRE1    | T1       | PRE2    | T2       |         |         |        |        |
| 18h           | TM      | PREX     | TX      | PREY     | TY      |         |        |        |
| 20h           | PWMCON  | PWM1P    | PWM1H   | PWM2P    | PWM2H   | PWM3PL  | PWM3PH | PWM3HL |
| 28h           | PWM3HH  | PWM4PL   | PWM4PH  | PWM4HL   | PWM4HH  |         |        |        |
| 30h           | UARTCON | UARTSTS  | BRGH    | BRGL     | UARTBUF |         |        |        |
| 38h           |         |          |         |          |         |         |        |        |
| 40h           | CIR     | BRD      | CIRFIFO |          |         |         |        |        |
| 48h           |         |          |         |          |         |         |        |        |
| 50h           | AD1     | AD2      | DA1     | DA2      |         |         |        |        |
| 58h           |         |          |         |          |         |         |        |        |
| 60h           | FAN1    | FAN2     |         |          |         |         |        |        |
| 68h           |         |          |         |          |         |         |        |        |
| 70H           | RTCSEC  | RTCSECAL | RTCMIN  | RTCMINAL | RTCHR   | RTCHRAL |        |        |
| 78H           |         |          |         |          |         |         |        |        |
| 80H           | EIE1    | EIE2     | EIE3    | EIREQ1   | EIREQ2  | EIREQ3  |        |        |
| 88H           | EINTT1  | EINTT2   | EINTT3  | EINTT4   |         |         |        |        |
| Index +       | 8       | 9        | A       | B        | C       | D       | E      | F      |

Read Only

Reserved



## 6.1 Turbo 8051 Core Block

The Turbo 8051 is fully instruction compatible. It features a faster running and better performance. It improves the performance not just by running at high frequency but also reduces the machine cycle duration from the standard 8051 period of twelve clocks to four clock cycles for the majority of instructions. This improves performance by an average of 1.5 to 3 times. The Turbo 8051 also provides dual Data Pointers (DPTRs) to speed up block data memory transfers.

In W83L951DG/FG, External Wakeup Source will only be controlled by external wakeup configure register, not be influenced by internal interrupt configuration, even relevant interrupt enable or global interrupt enable have not been set, can carry out action of wakeup chip equally.

Table 6-5 8051 Configure Register Define

| 8051 Configure Register (12) |           |                                 |        |        |        |        |        |              |       |
|------------------------------|-----------|---------------------------------|--------|--------|--------|--------|--------|--------------|-------|
| IntAddr                      | Name      | 7                               | 6      | 5      | 4      | 3      | 2      | 1            | 0     |
| D0                           | PSW       | CY                              | AC     | F0     | RS1    | RS0    | OV     | F1           | P     |
| E0                           | ACC       | Accumulator [7:0]               |        |        |        |        |        |              |       |
| F0                           | B         | B[7:0]                          |        |        |        |        |        |              |       |
| 81                           | SP        | Stack Pointer [7:0]             |        |        |        |        |        |              |       |
| 82                           | DPL1      | Data Pointer 1 [7:0]            |        |        |        |        |        |              |       |
| 83                           | DPH1      | Data Pointer 1 [15:8]           |        |        |        |        |        |              |       |
| 84                           | DPL2      | Data Pointer 2 [7:0]            |        |        |        |        |        |              |       |
| 85                           | DPH2      | Data Pointer 2 [15:8]           |        |        |        |        |        |              |       |
| 86                           | ID        | Device ID Register              |        |        |        |        |        |              |       |
| 87                           | REV       | Device Revised Version Register |        |        |        |        |        |              |       |
| 8C                           | DPSEL     |                                 |        |        |        |        |        |              | DPS   |
| 8D                           | INTEN     |                                 |        |        |        |        |        |              | INTEN |
| 8E                           | MMC       |                                 |        |        |        |        |        |              | MMEN  |
| 89                           | CHIPCTRL1 | PWM4EN                          | PWM3EN | PWM2EN | PWM1EN | UARTEN | ALPCEN | Clock Select |       |
| 8A                           | CHIPCTRL2 | D/AEN2                          | D/AEN1 | A/DEN  | RTCEN  | KEYEN  | WDTEN  | PD           | IDLE  |
| 8B                           | CHIPCTRL3 | FAN2EN                          | FAN1EN | CIREN  | APS2   | MPS2   | KPS2   | SM2EN        | SM1EN |

Table 6-6 External Wakeup Configure Register Define

| POWER DOWN CONFIGURE REGISTER |         |          |   |     |     |      |         |         |         |  |
|-------------------------------|---------|----------|---|-----|-----|------|---------|---------|---------|--|
| EXTADDR                       | NAME    | 7        | 6 | 5   | 4   | 3    | 2       | 1       | 0       |  |
| 8C                            | EXTWKP1 | Reserved |   |     |     | KEY  | EXTINT3 | EXTINT2 | EXTINT1 |  |
| 8D                            | EXTWKP2 | Reserved |   | RTC | LPC | APS2 | MPS2    | KPS2    |         |  |



## 6.1.1 Register Description

### 6.1.1.1 Program Status Word Register (PSW) (Default Value: 0000\_0000)

#### Bit7: Carry Flag (CY):

Set for an arithmetic operation, which results in a carry being generated from the ALU. It is also used as the accumulator for the bit operations.

#### Bit6: Auxiliary Carry (AC):

Set when the previous operation resulted in a carry (during addition) or borrow (during subtraction) from the high order nibble.

#### Bit5: User Flag 0 (F0):

General-purpose flag can be set or cleared by the user by software.

#### Bit4~3: Register bank selects bits (RS1, RS0):

| RS1 | RS0 | Register bank | Address Range |
|-----|-----|---------------|---------------|
| 0   | 0   | 0             | 00-07h        |
| 0   | 1   | 1             | 08-0Fh        |
| 1   | 0   | 2             | 10-17h        |
| 1   | 1   | 3             | 18-1Fh        |

#### Bit2: Overflow Flag (OV):

Set when a carry was generated from the seventh bit but not from the 8th bit as a result of the previous operation or vice-versa.

#### Bit1: User Flag 1 (F1):

General-purpose flag that can be set or cleared by the user by software

#### Bit0: Parity flag (P):

Set/cleared by hardware to indicate odd/even number of 1's in the accumulator.

Please refer to MCS-8051 define in detail.

### 6.1.1.2 Accumulator Register (ACC) (Default Value: 0000\_0000)

#### Bit7~0: Accumulator (A)

The A or ACC register is the standard 8032 accumulator. Please refer to MCS-8051 define in detail.

### 6.1.1.3 B Register (B) (Default Value: 0000\_0000)

#### Bit7~0: B

The B register is the standard 8032 accumulator. Please refer to MCS-8051 define in detail.

### 6.1.1.4 Stack Pointer Register (SP) (Default Value: 0000\_0111)

#### Bit7~0: Stack Pointer

The Stack Pointer stores the Scratch-pad RAM address where the stack begins. In other words it always points to the top of the stack. Note: The address range is 00h~FFh.

Please refer to MCS-8051 define in detail.



## 6.1.1.5 Data Pointer 1 High Byte Register (DPH1) (Default Value: 0000\_0000)

This is the high byte of the standard 8032 16-bit data pointer.

## 6.1.1.6 Data Pointer 1 Low Byte Register (DPL1) (Default Value: 0000\_0000)

This is the low byte of the standard 8032 16-bit data pointer.

## 6.1.1.7 Data Pointer 2 High Byte Register (DPH2) (Default Value: 0000\_0000)

Same as Data Pointer 1 High Byte Register, it is selected by DPSEL@DPS.

## 6.1.1.8 Data Pointer 2 Low Byte Register (DPL1) (Default Value: 0000\_0000)

Same as Data Pointer 1 High Byte Register, it is selected by DPSEL@DPS.

## 6.1.1.9 Device ID Register (ID) (Default Value: 0001\_0010)

Device ID Number = 12h.

## 6.1.1.10 Revised Version Register (REV) (Default Value: 0000\_0000)

Version Number = 00h

## 6.1.1.11 Data Pointer Select Register (DPSEL) (Default Value: 0000\_0000)

**Bit7~1: Reserved**

**Bit0: Select Data Pointer 1/2 Register (Default Value: 0)**

1: Data Pointer 2 Register

0: Data Pointer 1 Register

## 6.1.1.12 All Interrupt Enable Register (INTEN) (Default Value: 0000\_0000)

**Bit7~1: Reserved**

**Bit0: Enable 8051 All Interrupt Procedure**

1: Enable 8051 All Interrupt Procedure

0: Disable

## 6.1.1.13 Memory Mapping Control Register (MMC) (Default Value: 0000\_0000)

**Bit7~1: Reserved**

**Bit0: Enable Memory Mapping**

1: Enable, 0000~07FFh (Address) based on Data Address Map to F800~FFFFh based on

Code Address.

0: Disable



## 6.1.1.14 Chip Control 1 Register (CHIPCTRL1) (Default Value: 0000\_0000)

### Bit 7: Pulse Width Modulator 4 Function Enable

1: Enable Pulse Width Modulator 4 (GP27 GPIO Function Disable)

0: Power down Pulse Width Modulator 4

### Bit 6: Pulse Width Modulator 3 Function Enable

1: Enable Pulse Width Modulator 3 (GP26 GPIO Function Disable)

0: Power down Pulse Width Modulator 3

### Bit 5: Pulse Width Modulator 2 Function Enable

1: Enable Pulse Width Modulator 2 (GP25 GPIO Function Disable)

0: Power down Pulse Width Modulator 2

### Bit 4: Pulse Width Modulator 1 Function Enable

1: Enable Pulse Width Modulator 1 (GP24 GPIO Function Disable)

0: Power down Pulse Width Modulator 1

### Bit 3: UART Function Enable

1: Enable UART Block (GP42、GP43 GPIO Function Disable)

0: Power down UART Block

### Bit 2: Advance LPC Function Enable

1: Enable CLKRUN# Function. (GP46 GPIO Function Disable)

0: Disable

### Bit 1~0: System Clock Select

00: Input Clock, 01: Input Clock, 10: Input Clock/2, 11: Input Clock/4

## 6.1.1.15 Chip Control 2 Register (CHIPCTRL2) (Default Value: 0000\_0000)

### Bit 7: D/A 2 Function Enable

1: Enable DAC2 Block (GP56 GPIO Function Disable)

0: Power down DAC2 Block

### Bit 6: D/A 1 Function Enable

1: Enable DAC1 Block (GP57 GPIO Function Disable)

0: Power down DAC1 Block

### Bit 5: A/D Function Enable

1: Enable ADC Block (GP6 GPIO Function Disable)

0: Power down ADC Block



## **Bit 4: Real Time Clock Function Enable**

1: Enable RTC Block

0: Power down RTC Block

## **Bit 3: Keyboard Scan Function Enable**

1: Enable {GP0, GP1, GP20~23} Keyboard Scan Function and GP3 Key Wakeup Interrupt Function.

0: Disable

**Note:** To enable Keyboard Scan Function will switch {GP0, GP1, GP20~23} drive current from 12mA to 250uA.

## **Bit 2: Watch Dog Timer Function Enable**

1: Enable WDT Block

0: Power down WDT Block

## **Bit 1: Whole Chip Power down Enable**

1: Power down mode:

When there is no any external interrupt, Key Wake-up interrupt and LPC interrupt occurs or PS2 data line is low, W83L951DG/FG will stop external clock to enter power down mode, otherwise it will clear this bit as 0 automatically.

0: Normal Mode:

When any external interrupt or Key Wake-up interrupt occurs or PS2 data line goes low, this bit will clear this bit as 0 automatically.

Note: If whole chip power down mode and idle mode are both enabled, after leaving power down mode, W83L951DG/FG will enter idle mode to wait for internal interrupt.

## **Bit 0: Whole Chip Idle Enable**

1: Idle Mode:

When there is no any interrupt occurs, W83L951DG/FG will enter idle mode, otherwise it will clear this bit as 0 automatically.

0: Normal Mode:

It will clear this bit as 0 when all interrupt events occur.

## **6.1.1.16 Chip Control 3 Register (CHIPCTRL3) (Default Value: 0000\_0000)**

### **Bit 7: FAN 2 Function Enable**

1: Enable FAN1 Block (GP40 GPIO Function Disable)

0: Power down FAN1 Block

### **Bit 6: FAN 1 Function Enable**

1: Enable FAN2 Block (GP41 GPIO Function Disable)

0: Power down FAN2 Block

**Bit 5: CIR Function Enable**

1: Enable CIR Block (GP84 GPIO Function Disable)

0: Power down CIR Block

**Bit 4: Auxiliary PS2 Function Enable**

1: Enable Auxiliary PS2 Block (GP70、GP71 GPIO Function Disable)

0: Power down Auxiliary PS2 Block (The Wakeup by APS2 is also disabled)

**Bit 3: Mouse PS2 Function Enable**

1: Enable Mouse PS2 Block (GP72、GP73 GPIO Function Disable)

0: Power down Mouse PS2 Block (The Wakeup by MPS2 is also disabled)

**Bit 2: Keyboard PS2 Function Enable**

1: Enable Keyboard PS2 Block (GP70、GP71 GPIO Function Disable)

0: Power down Keyboard PS2 Block (The Wakeup by KPS2 is also disabled)

**Bit 1: SMBUS 2 Function Enable**

1: Enable SMBUS2 Block (GP80、GP81 GPIO Function Disable)

0: Power down SMBUS2 Block

**Bit 0: SMBUS 1 Function Enable**

1: Enable SMBUS1 Block (GP76、GP77 GPIO Function Disable)

0: Power down SMBUS1 Block

**6.1.1.17 External Wake-up 1 Register (EXTWKP1) (Default Value: 0000\_0000)****Bit7~4: Reserved****Bit3: Enable Key Wake-up Interrupt wake-up W83L951DG/FG at power down mode.**

1: Enable.

0: Disable.

**Bit2: Enable External Interrupt 3 wake-up W83L951DG/FG at power down mode.**

1: Enable.

0: Disable.

**Bit1: Enable External Interrupt 2 wake-up W83L951DG/FG at power down mode.**

1: Enable.

0: Disable.

**Bit0: Enable External Interrupt 1 wake-up W83L951DG/FG at power down mode.**

1: Enable.

0: Disable.





## 6.1.1.18 External Wake-up 2 Register (EXTWKP2) (Default Value: 0000\_0000)

**Bit7~5: Reserved**

**Bit4: Enable RTC Interrupt wake-up W83L951DG/FG at power down mode.**

1: Enable.

0: Disable.

**Bit3: Enable LPC Interrupt wake-up W83L951DG/FG at power down mode.**

1: Enable.

0: Disable.

**Bit2: Enable APS2 Interrupt wake-up W83L951DG/FG at power down mode.**

1: Enable.

0: Disable.

Note: Before enabling the function, Auxiliary PS2 Noise Filter Enable Bit (NFEN@PS2CON) must be set low.

**Bit1: Enable MPS2 Interrupt wake-up W83L951DG/FG at power down mode.**

1: Enable.

0: Disable.

Note: Before enabling the function, Mouse PS2 Noise Filter Enable Bit (NFEN@PS2CON) must be set low.

**Bit0: Enable KPS2 Interrupt wake-up W83L951DG/FG at power down mode.**

1: Enable.

0: Disable.

Note: Before enabling the function, Keyboard PS2 Noise Filter Enable Bit (NFEN@PS2CON) must be set low.



## 6.2 Low Pin Count Interface Block

Table 6-7 Low Pin Count Interface Register Define

| LOW PIN COUNT INTERFACE(LPC) & SERIAL IRQ & DATA BUFFER BLOCK(10) |          |                                 |        |          |          |                   |          |          |          |
|---|----------|---------------------------------|--------|----------|----------|-------------------|----------|----------|----------|
| INTA<br>DDR   | NAME     | 7                               | 6      | 5        | 4        | 3                 | 2        | 1        | 0        |
| 91  | KBCCON   | Reserved                        |        |          | P92EN    | HKBEN             | HGAEN    | GA20SET  | GA20CLR  |
| 92  | LPCCON   | DBB1En                          | DBB0En | SIRQ11EN | SIRQ10EN | SIRQ01EN          | SIRQ00EN | SIRQ1GEN | SIRQ0GEN |
| 93  | DBB0STS  | UDF[3:0]                        |        |          |          | CD0               | UDF      | IBF0     | OBF0     |
| 94  | DBB0     | Data Buffer 0 [7:0]             |        |          |          |                   |          |          |          |
| 95  | DBB0ADDH | Data Buffer 0 Address High Byte |        |          |          |                   |          |          |          |
| 96  | DBB0ADDL | Data Buffer 0 Address Low Byte  |        |          |          |                   |          |          |          |
| 97  | SIRQ0    | OBF01 SIRQ Number               |        |          |          | OBF00 SIRQ Number |          |          |          |
| 99  | DBB1STS  | UDF[3:0]                        |        |          |          | CD1               | UDF      | IBF1     | OBF1     |
| 9A  | DBB1     | Data Buffer 1 [7:0]             |        |          |          |                   |          |          |          |
| 9B  | DBB1ADDH | Data Buffer 1 Address High Byte |        |          |          |                   |          |          |          |
| 9C  | DBB1ADDL | Data Buffer 1 Address Low Byte  |        |          |          |                   |          |          |          |
| 9D  | SIRQ1    | OBF11 SIRQ Number               |        |          |          | OBF10 SIRQ Number |          |          |          |

**Gray:** Only with System Reset to initial.

### 6.2.1 Register Description

#### 6.2.1.1 DBB0 Status Register (DBB0STS) (Default Value: 0000\_?0?0)

**Bit7~4: User Define Flag**

**Bit3: Indicate IDBB0 Command/Data (By LRESET\_N Pin to reset)**

1: Command, 0: Data.

**Bit2: User Define Flag**

**Bit1: Input Buffer Full Flag (By LRESET\_N Pin to reset)**

1: Full, 0: Empty

**Bit0: Output Buffer Full Flag**

1: Full, 0: Empty

#### 6.2.1.2 Data Bus Buffer 0 Register (DBB0) (Default Value: 0000\_0000)

Write data to output buffer, and read data from input buffer.



## **6.2.1.3 Data Bus Buffer 0 Address High Byte Register (DBB0ADDH) (Default Value: 0000\_0000)**

DBB0 address is according to {DBB0ADDH, DBB0ADDL}. Default I/O address is 0x00h.

If transmission is proceeding, address is encoded and decoded in next package.

## **6.2.1.4 Data Bus Buffer 0 Address Low Byte Register (DBB0ADDL) (Default Value: 0000\_0000)**

DBB0 address is according to {DBB0ADDH, DBB0ADDL}. Default I/O address is 0x00h.

If transmission is proceeding, address is encoded and decoded in next package.

## **6.2.1.5 Low Pin Count Control Register (LPCCON) (Default Value: 0000\_0000)**

### **Bit7: Data Bus Buffer 1 Enable**

1: Enable (If transmission is proceeding, address is encoded and decoded in next package.)

0: Disable

### **Bit6: Data Bus Buffer 0 Enable**

1: Enable (If transmission is proceeding, address is encoded and decoded in next package.)

0: Disable

### **Bit5: Serial IRQ 11 Enable**

1: Enable (Start generating Serial IRQ for OBF1)

0: Disable (Stop generating Serial IRQ for OBF1)

### **Bit4: Serial IRQ 10 Enable**

1: Enable (Start generating Serial IRQ for OBF1)

0: Disable (Stop generating Serial IRQ for OBF1)

### **Bit3: Serial IRQ 01 Enable**

1: Enable (Start generating Serial IRQ for OBF0)

0: Disable (Stop generating Serial IRQ for OBF0)

### **Bit2: Serial IRQ 00 Enable**

1: Enable (Start generating Serial IRQ for OBF0)

0: Disable (Stop generating Serial IRQ for OBF0)

### **Bit1: Serial IRQ 1 Generate Start Bit**

W83L951DG/FG hardware checks this bit in every starting of Serial IRQ procedure. If this bit is high, W83L951DG/FG will generate Serial IRQ corresponding to OBF1 SIRQ Number @SIRQ. This bit clears as low automatically after W83L951DG/FG receives request and enters Serial IRQ procedure. This bit is set as high in writing this bit and data is written to Data Bus Buffer 1 Register.

This bit is to provide the method to generate Serial IRQ that is needless through writing to Data Bus Buffer 1 Register.



## **Bit0: Serial IRQ 0 Generate Start Bit**

W83L951DG/FG hardware checks this bit in every starting of Serial IRQ procedure. If this bit is high, W83L951DG/FG will generate Serial IRQ corresponding to OBF0 SIRQ Number @SIRQ. This bit clears as low automatically after W83L951DG/FG receives request and enters Serial IRQ procedure. This bit is set as high in writing this bit and data is written to Data Bus Buffer 0 Register.

This bit is to provide the method to generate Serial IRQ that is needless through writing to Data Bus Buffer 0 Register.

## **6.2.1.6 Serial IRQ 0 Number (SIRQ0) (Default Value: 0000\_0000)**

### **Bit7~4: Serial IRQ 01 Number**

If transmission is proceeding, IRQ number will be changed in next transmission. Set as 0000, SIRQ01 is disabled.

### **Bit3~0: Serial IRQ 00 Number**

If transmission is proceeding, IRQ number will be changed in next transmission. Set as 0000, SIRQ00 is disabled.

## **6.2.1.7 Serial IRQ 1 Number (SIRQ1) (Default Value: 0000\_0000)**

### **Bit7~4: Serial IRQ 11 Number**

If transmission is proceeding, IRQ number will be changed in next transmission. Set as 0000, SIRQ11 is disabled.

### **Bit3~0: Serial IRQ 10 Number**

If transmission is proceeding, IRQ number will be changed in next transmission. Set as 0000, SIRQ10 is disabled.

## **6.2.1.8 Keyboard Control Register (KBCCON)(Default Value: 0000\_0001)**

### **Bit7~5: Serial IRQ Hold Counter for Serial IRQ Generate Function**

000: Generate 1 cycle of Serial IRQ.

001: Generate 2 cycles of Serial IRQ.

010: Generate 3 cycles of Serial IRQ.

011: Generate 4 cycles of Serial IRQ.

100: Generate 5 cycles of Serial IRQ.

101: Generate 6 cycles of Serial IRQ.

110: Generate 7 cycles of Serial IRQ.

111: Generate 8 cycles of Serial IRQ.



## **Bit4: Port 92 Enable (Default Value: 0)**

1: Enable W83L951DG/FG's hardware logic to receive the data written in I/O address@0092h. Bit1 and bit0 of port92 control register controls Gate A20 and KBRST pin. Gate A20 will drive high when bit1 is 1 and KBRESET pin drive {14us High → 6us Low → High} waveform when bit0 is 1. Gate A20 is default high level after LPC reset and GP44, GP45 GPIO function is disabled.

0: Disable

## **Bit3: Hardware Keyboard Reset Control Enable (Default Value: 0)**

1: Enable W83L951DG/FG's hardware logic to set KBRESET. When the KBC receives data that follows a "FE" command, the KBRESET pin drives {14us High → 6us Low → High} waveform. And GP44 GPIO function is disabled.

0: Disable

## **Bit2: Hardware Gate A20 Control Enable (Default Value: 0)**

1: Enable W83L951DG/FG's hardware logic to set Gate A20. When the KBC receives data that follows a "D1" command, the Gate A20 pin drives high. And GP45 GPIO function is disabled.

0: Disable

## **Bit1: Gate A20 Set**

Set directly Gate A20 Output Register. If host is setting from LPC Interface, the request will be ignored. This belongs to software control.

## **Bit0: Gate A20 Clear/Gate A20 Status**

Write: Clear directly Gate A20 Output Register. If host is setting from LPC Interface, the request will be ignored. This belongs to software control.

Read: Current Internal Gate A20 Status.

## **6.2.1.9 DBB1 Status Register (DBB1STS) (Default Value: 0000\_?0?0)**

### **Bit7~4: User Define Flag**

### **Bit3: Indicate IDBB Command/Data (By LRESET# Pin to reset)**

1: Command, 0: Data.

### **Bit2: User Define Flag**

### **Bit1: Input Buffer Full Flag (By LRESET# Pin to reset)**

1: Full, 0: Empty

### **Bit0: Output Buffer Full Flag**

1: Full, 0: Empty



## **6.2.1.10 Data Bus Buffer 1 Register (DBB1) (Default Value: 0000\_0000)**

The output buffer register and the input buffer register are located at the same address. The output buffer is write-only and the input buffer is read-only.

## **6.2.1.11 Data Bus Buffer 1 Address High Byte Register (DBB1ADDH) (Default Value: 0000\_0000)**

DBB1 address is according to {DBB1ADDH, DBB1ADDL}. Default I/O address is 0x00h. If transmission is proceeding, address will be encoded and decoded in next package, not in current package.

## **6.2.1.12 Data Bus Buffer 1 Address Low Byte Register (DBB1ADDL) (Default Value: 0000\_0000)**

DBB1 address is according to {DBB1ADDH, DBB1ADDL}. Default I/O address is 0x00h. If transmission is proceeding, address will be encoded and decoded in next package, not in current package.



## 6.3 Personal System 2 Block

The Winbond Keyboard controller has three independent PS/2 serial ports implemented in hardware, which are directly controlled by the on chip 8051. Each of the three PS/2 serial channels uses a synchronous serial protocol to communicate with the auxiliary device. Each PS/2 channel has two signal lines: Clock and Data. Both signal lines are bi-directional and employ open drain. The PS2DATA, PS2CON and PS2STS is defined individually for each PS/2 channel. PS2HSEN is only one register for controlling all PS/2 device handshake action.

Table 6-8 Personal System 2(PS2) Register Define

| KEYBOARD & MOUSE & AUXILIARY PS2 BLOCK(9) |          |                          |           |          |           |        |    |          |          |
|---|----------|--------------------------|-----------|----------|-----------|--------|----|----------|----------|
| INTADDR                                   | NAME     | 7                        | 6         | 5        | 4         | 3      | 2  | 1        | 0        |
| A1  | KPS2DATA | KPS2 Data register [7:0] |           |          |           |        |    |          |          |
| A2  | KPS2CON  | NFEN                     | Inhibit   | STOP     |           | PARITY |    | Reserved | KPS2T/R  |
| A3  | KPS2STS  | KPS2BUSY                 | START_DEC | TTIMEOUT | XMIT_BUSY | FE     | PE | RTIMEOUT | RDAT_RDY |
| A4  | MPS2DATA | MPS2 Data register [7:0] |           |          |           |        |    |          |          |
| A5  | MPS2CON  | NFEN                     | Inhibit   | STOP     |           | PARITY |    | Reserved | MPS2T/R  |
| A6  | MPS2STS  | MPS2BUSY                 | START_DEC | TTIMEOUT | XMIT_BUSY | FE     | PE | RTIMEOUT | RDAT_RDY |
| A7  | PS2HSEN  | Reserved                 |           |          |           |        |    |          | HSEN     |
| A9  | APS2DATA | APS2 Data register [7:0] |           |          |           |        |    |          |          |
| AA  | APS2CON  | NFEN                     | Inhibit   | STOP     |           | PARITY |    | Reserved | APS2T/R  |
| AB  | APS2STS  | APS2BUSY                 | START_DEC | TTIMEOUT | XMIT_BUSY | FE     | PE | RTIMEOUT | RDAT_RDY |

**Gray:** Only with System Reset to initial.

### 6.3.1 Register Description

#### 6.3.1.1 PS/2 Handshake Enable Register (PS2HSEN) (Default Value:: 0000\_0000)

**Bit 7~1: Reserved (always return 'LOW')**

**Bit 0: Handshake Mode Enable (HSEN)**

0: The handshake mode of PS2 disables.

1: The handshake mode of PS2 enables.

When the handshake mode of PS2 is enabling, the TR bit (BIT 0) of PSCON is automatically set high when the START\_DEC bit (bit 6) of PS2STS of the other channel is set.

*Note:*

*The priority of three PS2 interface is KPS2 > MPS2 > APS2.*

*Whether the handshake mode of PS2 is enabling or no, the TR bit (BIT 0) of PSCON is automatically set high when the RDATA\_RDY bit (bit 0) of PS2STS of this channel is set.*



## 6.3.1.2 PS/2 T/R DATA Registers (PS2DATA) (Default Value: 1111\_1111)

### Transmit:

The byte written to this register, when PS2\_T/R = 1 and PS2\_EN = 1 and XMIT\_BUSY = 0, is transmitted automatically by the PS/2 channel control logic. On successful start of this transmission, the PS2 logic will automatic set XMIT\_BUSY to high. If PS2\_T/R = 0 or PS2\_EN = 0 or XMIT\_BUSY = 1, then writes to this register are ignored.

On successful completion of this transmission or upon a Transmit Time-out condition the PS2\_T/R and XMIT\_BUSY bit is automatically set to low. The PS2\_T/R bit must be written to a HIGH before initiating another transmission to the remote device.

*Note:*

*Even if PS2\_T/R = 1 and PS2\_EN = 1 and XMIT\_BUSY = 0, writing the transmit Register will hold the current transmission if RDATA\_RDY is set. The automatic PS2 logic forces data to be read from the Receive Register before allowing a transmission.*

*An interrupt is generated on the high to low transition of XMIT\_BUSY.*

*All bits of this register are write-only for transmit data, because you always read received data.*

### Receive:

When PS2\_EN=1 and PS2\_T/R=0, the PS2 Channel is set to automatically receive data on that channel (both the CLK and DATA lines will float waiting for the peripheral to initiate a reception by sending a start bit followed by the data bits). After a successful reception data is placed in this register and the RDATA\_RDY bit is set and the CLK line is forced low by the PS2 channel logic. RDATA\_RDY is cleared and the CLK line is released to hi-z following a read of this register. This automatically holds off further receive transfers until the 8051 has had a chance to get the data.

*Note:*

*The Receive Register is initialized to 0xFF after a Timeout has occurred.*

*The channel can be enabled to automatically transmit data (PS2\_EN=1) by setting PS2\_T/R while RDATA\_RDY is set, however a device (not include host) transmission can hold until the data has been read from the Receive Register.*

*An interrupt is generated on the low to high transition of RDATA\_RDY.*

*If a receive timeout (REC\_TIMEOUT=1) or a transmit timeout (XMIT\_TIMEOUT =1) occurs the channel is busied (CLK held low) for 300us(Input clock=24MHz) or 600us(Input clock=12MHz) (Hold Time) to guarantee that the peripheral aborts. Writing to the Transmit Register will be allowed; however the data written will not be transmitted until the Hold Time expires.*

*In the foregoing situation, RDATA\_RDY won't automatically clear.*





## 6.3.1.3 PS/2 Control Registers (PS2CON) (Default Value:: 0000\_0000)

### Bit 7: NOISE FILTER ENABLE (NFEN)

0: Disable noise filter for clock line

1: Enable noise filter for clock line

### Bit 6: Inhibit bit

The low to high transition of the inhibit bit will hold the clock line low for 100us(Input clock=24MHz) or 200us(Input clock=12MHz).

### Bit 5-4: STOP

Bits [5:4] of the Control Register are used to set the level of the stop bit expected by the PS/2 channel state machine. These bits are therefore only valid when PS2\_EN=1.

Bits [5:4] =

00: Receiver expects an active high stop bit.

01: Receiver expects an active low stop bit.

10: Receiver ignores the level of the Stop bit (11th bit is not interpreted as a stop bit).

11: Reserved.

### Bit 3-2: PARITY

Bits [3:2] of the Control Register are used to set the parity expected by the PS/2 channel state machine. These bits are therefore only valid when PS2\_EN=1.

Bits [3:2] =

00: Receiver expects Odd Parity (Default Value:).

01: Receiver expects Even Parity.

10: Receiver ignores level of the parity bit (10th bit is not interpreted as a parity bit).

11: Reserved.

### Bit 1: PS2\_EN PS2 Channel Enable

When PS2\_EN=1 the PS/2 State machine is enabled allowing the channel to perform automatic reception or transmission depending on the bit value of PS2\_T/R. When PS2\_EN = 0, the channel's automatic PS/2 state machine is disabled.

#### *Note:*

*If the PS2\_EN bit is cleared prior to the rising edge of the 10th (parity bit) clock edge the receive data is discarded (RDATA\_RDY remains low).*

*If the PS2\_EN bit is cleared following the rising edge of the 10th clock signal then the receive data is saved in the Receive Register (RDATA\_RDY goes high) assuming no parity error.*

*In the foregoing two situations, ps2 device can't differentiate host receive data success or fail, and therefore we don't recommend to use this function. It shall set to high before you start any operation of PS2.*



## Bit 0: PS2\_T/R PS/2 Channel Transmit/Receive

This bit is only valid when PS2\_EN=1 and sets the PS2 logic for automatic transmission or reception when PS2\_T/R equals HIGH or LOW respectively (This bit may be modified, after unsetting PS2\_EN).

When set the PS/2 channel is enabled to transmit data. To properly initiate a transmit operation this bit must be set prior to writing to the Transmit Register; writes are blocked to the Transmit Register when this bit is not set.

Upon setting the PS2\_T/R bit the channel will drive its CLK line low and then float the DATA line and hold this state until a write occurs to the Transmit Register or until the PS2\_T/R bit is cleared. Writing to the Transmit Register initiates the transmit operation. KB controller drives the data line low and, within 100us, floats the clock line (externally pulled high by the pull-up resistor) to signal to the external PS/2 device that data is now available.

The PS2\_T/R bit is cleared on the 11th clock edge of the transmission or if a Transmit Timeout error condition occurs.

*Note: If the PS2\_T/R bit is set while the channel is actively receiving data prior to the rising edge of the 10th (parity bit) clock edge the receive data is discarded. If this bit is not set prior to the 10th clock signal then the receive data is saved in the Receive Register.*

*When the PS2\_T/R bit is cleared the PS/2 channel is enabled to receive data. Upon clearing this bit, whether RDATA\_RDY=0 or no, the channel's CLK and DATA will float waiting for the external PS/2 device to signal the start of a transmission for receiving data. But if RDATA\_RDY=1, the hardware won't generate interrupt to indicate finished receive data.*

*If the PS2\_T/R bit is set while RDATA\_RDY=1 then the channel's DATA line will float but its CLK line will be held low, holding off the peripheral, until the Receive Register is read.*

## 6.3.1.4 PS/2 Status Registers (PS2STS) (Default Value:: 0000\_0000)

### Bit 7: Receiver Busy (RX\_BUSY)

This bit is indicators for each of the three PS/2 Channels. When a RX\_BUSY bit is set the associated channel is actively receiving PS/2 data; when a RX\_BUSY bit is clear the channel is idle.

### Bit 6: Start Bit Detect (START\_DEC)

This bit is set on detecting start bit of receive conditions. Writing high will clear this bit.

### Bit 5: Transmitter Timeout (XMIT\_TIMEOUT)

This bit is set on one of 3 transmit conditions, and in addition the channel's CLK line is automatically pulled low and held for a period of 300us(Input clock=24MHz) or 600us(Input clock=12MHz) following assertion of the XMIT\_TIMEOUT bit during which time the PS2\_T/R is also held low:

When the transmitter bit time (time between falling edges) exceeds 300us(Input clock=24MHz) or 600us(Input clock=12MHz).

When the transmitter start bit is not received within 25ms(Input clock=24MHz) or 50ms(Input clock=12MHz) from signaling a transmit start event.

If the time from the 1st (start, falling edge) bit to the 11th (stop, falling edge) bit exceeds 2ms.

Writing high will clear this bit.



## **Bit 4: Transmitter Busy (XMIT\_BUSY)**

When high, the XMIT\_BUSY bit is a status bit indicating that the PS2 channel is actively transmitting data to the PS2 peripheral device. Writing to the Transmit Register whether the channel ready to transmit will cause the XMIT\_BUSY bit to assert and remain asserted until one of the following conditions occur and an Interrupt is generated..

The falling edge of the 11th CLK; upon a Transmit Timeout condition (XMIT\_TIMEOUT goes high);

Upon the PS2\_T/R bit being written to 0.

Upon the PS2\_EN bit being written to 0.

*Note: An interrupt is generated on the high to low transition of XMIT\_BUSY.*

## **Bit 3: Framing Error (FE)**

When receiving data the stop bit is clocked in on the falling edge of the 11th CLK edge. If the channel has been set to expect either a high or low stop bit and the 11th bit is contrary to the expected stop polarity, then the FE and REC\_TIMEOUT bits are set following the falling edge of the 11th CLK edge and an Interrupt is generated. Writing high will clear this bit.

## **Bit 2: Parity Error (PE)**

When receiving data the parity bit is clocked in on the falling edge of the 10th CLK edge. If the channel has been set to expect either even or odd parity and the 10th bit is contrary to the expected parity, then the PE and REC\_TIMEOUT bits are set following the falling edge of the 10th CLK edge and an Interrupt is generated. Writing high will clear this bit.

## **Bit 1: Receiver Timeout (REC\_TIMEOUT)**

Under PS2 automatic operation, PS2\_EN=1, this bit is set on one of 4 receive error conditions, and in addition the Channel's CLK line is automatically pulled low and held for a period of 300us following assertion of the REC\_TIMEOUT bit:

When the receiver bit time (time between falling edges) exceeds 300us(Input clock=24MHz) or 600us(Input clock=12MHz).

If the time from the 1st (start, falling edge) bit to the 10th (stop, falling edge) bit exceeds 2ms.

On a receive parity error along with the parity error (PE) bit.

On a receive framing error due to an incorrect STOP bit along with the framing error (FE) bit. Writing high will clear this bit.

*Note: An Interrupt is generated on the low to high transition of the REC\_TIMEOUT bit.*

## **Bit 0: Data Ready (RDATA\_RDY)**

Receive Data Ready: Under normal operating conditions, this bit is set following the falling edge of the 11th clock given successful reception of a data byte from the PS/2 peripheral (i.e., no parity, framing, or receive timeout errors) and indicates that the received data byte is available to be read from the Receive Register. This bit may also be set in the event that the PS2\_EN bit is cleared following the 10th CLK edge (see the PS2\_EN bit description for further details). Writing high will clear this bit.

*Note: An Interrupt is generated on the low to high transition of the RDATA\_RDY bit.*



## 6.4 System Management Bus Block

W83L951DG/FG provides 2 System Management Bus (SMBus) host controllers. The SMBus host controllers is SMBUS 2.0 compatible. It also provides 32 bytes FIFO. The FIFO contains SMBus1 Master Data FIFO(8), SMBus2 Master Data FIFO(8).

Table 6-9 SMBus 1 Register Define

| SMBUS 1 BLOCK(24) |             |                        |          |                       |            |          |          |                  |           |  |  |
|-------------------|-------------|------------------------|----------|-----------------------|------------|----------|----------|------------------|-----------|--|--|
| INTADDR           | NAME        | 7                      | 6        | 5                     | 4          | 3        | 2        | 1                | 0         |  |  |
| B1                | SM1SCR      | Reserved               |          | Baud Rate Select      |            |          | RBIM     | Reserved         | Reserved  |  |  |
| B2                | SM1IREQ     | MSTS                   | MFIFORdy | MFIFOReq              | MPktFinish |          |          |                  |           |  |  |
| B3                | SM1IE       | Interrupt Enable [7:0] |          |                       |            |          |          |                  |           |  |  |
| B4                | SM1FIFOCON  | STOP                   | RepStart | Master Level[1:0]     |            | ClrMFIFO | ClrSFIFO | Slave Level[1:0] |           |  |  |
| B5                | SM1MFIFO    | Master Data FIFO [7:0] |          |                       |            |          |          |                  |           |  |  |
| B6                | SM1MCON     | MasterEn               | RMS      | Read Byte Count[5:0]  |            |          |          |                  |           |  |  |
| B7                | SM1MSTS     | RxTMO                  | TxTMO    | AIFull                | AIEmpty    | WrErr    | NACKRe   | ArbFail          | ClrFinish |  |  |
| B9                | SM1MFIFOSTS | Full                   | Empty    | FIFO Data Length[5:0] |            |          |          |                  |           |  |  |
| BA                | Reserved    |                        |          |                       |            |          |          |                  |           |  |  |
| BB                | Reserved    |                        |          |                       |            |          |          |                  |           |  |  |
| BC                | Reserved    |                        |          |                       |            |          |          |                  |           |  |  |
| BD                | Reserved    |                        |          |                       |            |          |          |                  |           |  |  |

Table 6-10 SMBus 2 Register Define

| SMBUS 2 BLOCK(24) |             |                        |          |                       |            |          |          |                  |           |  |  |
|-------------------|-------------|------------------------|----------|-----------------------|------------|----------|----------|------------------|-----------|--|--|
| INTADDR           | NAME        | 7                      | 6        | 5                     | 4          | 3        | 2        | 1                | 0         |  |  |
| C1                | SM2SCR      | Reserved               |          | Baud Rate Select      |            |          | RBIM     | Reserved         | Reserved  |  |  |
| C2                | SM2IREQ     | MSI                    | MFIFORdy | MFIFOReq              | MPktFinish |          |          |                  |           |  |  |
| C3                | SM2IE       | Interrupt Enable [7:0] |          |                       |            |          |          |                  |           |  |  |
| C4                | SM2FIFOCON  | STOP                   | RepStart | Master Level[1:0]     |            | ClrMFIFO | ClrSFIFO | Slave Level[1:0] |           |  |  |
| C5                | SM2MFIFO    | Master Data FIFO [7:0] |          |                       |            |          |          |                  |           |  |  |
| C6                | SM2MCON     | MasterEn               | RMS      | Read Byte Count[5:0]  |            |          |          |                  |           |  |  |
| C7                | SM2MSTS     | RxTMO                  | TxTMO    | AIFull                | AIEmpty    | WrErr    | NACKRec  | ArbFail          | ClrFinish |  |  |
| C9                | SM2MFIFOSTS | Full                   | Empty    | FIFO Data Length[5:0] |            |          |          |                  |           |  |  |
| CA                | Reserved    |                        |          |                       |            |          |          |                  |           |  |  |
| CB                | Reserved    |                        |          |                       |            |          |          |                  |           |  |  |
| CC                | Reserved    |                        |          |                       |            |          |          |                  |           |  |  |
| CD                | Reserved    |                        |          |                       |            |          |          |                  |           |  |  |

**Gray:** Only with System Reset to initial.



## 6.4.1 Register Description

### 6.4.1.1 System Control Register (SM1/2SCR) (Default Value: 0001\_10?0)

#### Bit 7~6: Reserved (Must Assign Low)

#### Bit 5~3: Baud Rate Select

Select SMBus baud rate.

Input Clock is 24MHz :

When System Clock is 24MHz:

000: 12.5 KHz, 001: 25 KHz, 010: 50 KHz, 011: 100 KHz

100: 400 KHz, 101: 800 KHz, 110: 1.2 MHz, 111: 2.4 MHz

When System Clock is 12MHz:

000: 12.5 KHz, 001: 25 KHz, 010: 50 KHz, 011: 100 KHz

100: 400 KHz, 101: 800 KHz, 110: 1.2 MHz, 111: N/A

When System Clock is 6MHz:

000: 12.5 KHz, 001: 25 KHz, 010: 50 KHz, 011: 100 KHz

100: 400 KHz, 101: 800 KHz, 110: N/A, 111: N/A

Input Clock is 12MHz

When System Clock is 12MHz:

000: 6.25 KHz, 001: 12.5 KHz, 010: 25 KHz, 011: 50 KHz

100: 200 KHz, 101: 400 KHz, 110: 600 KHz, 111: 1.2 MHz

When System Clock is 6MHz:

000: 6.25 KHz, 001: 12.5 KHz, 010: 25 KHz, 011: 50 KHz

100: 200 KHz, 101: 400 KHz, 110: 600 KHz, 111: N/A

When System Clock is 3MHz:

000: 6.25 KHz, 001: 12.5 KHz, 010: 25 KHz, 011: 50 KHz

100: 200 KHz, 101: 400 KHz, 110: N/A, 111: N/A

#### Bit 2: Rx Byte Interrupt Mode

Select the mode that SMBus receive data bytes to generate Master/Slave Data Ready interrupt.

0: Only First Byte and FIFO Full Byte:

Master/Slave Data Ready Interrupt only occurs in receiving first byte after Start phase or Repeat\_Start phase and any byte that make FIFO enter Full state.

1: Every Byte:

Master/Slave Data Ready Interrupt occurs in every time to finish receiving one byte.



**Bit 1: SMBALERT Pin Status (Reserved)**

**Bit 0: SMBALTER Event Control (Reserved)**

Control the occurrence of SMBALTER Event

0: Disable

1: Enable.

#### **6.4.1.2 Interrupt Register (SM1/2IREQ) (Default Value: 0000\_0000)**

**Bit 7: Master Status**

Indicate Master Status Register changed.

**Bit 6: Master FIFO Data Ready Interrupt**

Indicate that FIFO finishes receiving data byte when Master is under MSR (Master at Receiving) mode. About detail description, please refer Bit7@SM1/2SCR.

**Bit 5: Master FIFO Data Request Interrupt**

Indicate that FIFO request micro-processor provides data for transmitting to Slave when Master is under MST (Master at Transmitting) mode and empty.

**Bit 4: Master Packet Finished Interrupt**

Indicate that Master finishes package transmission (Include Rx and Tx).

**Bit 3~0: Reserved**

#### **6.4.1.3 Interrupt Enable Register (SM1/2IE) (Default Value: 0000\_0000)**

**All Bits:**

1: Enable Interrupt.

The content of Interrupt Register via OR operation will convert into Microprocessor Internal Interrupt Source.

0: Disable Interrupt.

Disable convert into Microprocessor Internal Interrupt, but relative interrupt flag will still be produced.

#### **6.4.1.4 FIFO Control Register (SM1/2FIFOCN) (Default Value: 0000\_0000)**

**Bit 7: STOP Tag Flag (Only for Master)**

Indicate that writing byte is the last byte.

**Bit 6: Repeat\_Start Tag Flag (Only for Master)**

Indicate that writing byte is Repeat\_Start Byte.

**Bit 5~4: Master FIFO Threshold Level Select**

00: AE – 2, AF – 6, 01: AE - 3, AF – 5

10: AE – 4, AF – 4, 11: Disable

*Note: AE is Almost Empty Flag, AF is Almost Full Flag.*



### Bit 3: Clear Master FIFO

Clear Master FIFO. Master will stop transfer immediately and generate Stop phase. After SMBus finishes the action, SMBus responds to micro-processor via FIFO Clear Finished Event in Master Status Register.

### Bit 2~0: Reserved

#### 6.4.1.5 Master Data FIFO Register (SM1/2MFIFO) (Default Value: 0000\_0000)

This FIFO register stores the data from Master.

Only allow writing in MST mode, and only allowed to read in MSR mode. Default is MST mode and transforming is through Data\_Ready\_Interrupt.

#### 6.4.1.6 Master Control Register (SM1/2MCON) (Default Value: 0100\_0000)

##### Bit 7: Master Enable

##### Bit 6: Read Mode Select

1: Host Read One Byte Hold Mode.

Master holds bus (drive SCL low) after finishing receiving every byte.

0: Host Read Continue Mode.

Master finishes {Receiving Package -> Stop Phase -> Release Bus} automatically according to read byte count.

*Note: If Read Byte Count initial value is 1, Master will ignore criterion of "Host Read One Byte Hold Mode".*

##### Bit 5~0: Read Byte Count

Indicate Read Byte Count. The allowed maximum is 64 bytes block read.

| Filled Value | Actual Value |
|--------------|--------------|
| 0            | 64           |
| 1~63         | 1~63         |

#### 6.4.1.7 Master Status Register (SM1/2MSTS) (Default Value: 0000\_0000)

##### Bit 7: Master Rx Timeout Event

Indicate Master generates RX\_TIMEOUT (When Master FIFO is full, SCL drive low to generate timeout). After the Master generates Stop Phase, will be back to initial state and clear FIFO.

*Note: If timeout is not generated by the Master, the response will occur in FIFO Clear Finished Event in Master Status Register.*

##### Bit 6: Master Tx Timeout Event

Indicate Master generates TX\_TIMEOUT (When Master FIFO is empty, SCL drive low to generate timeout). After Master generates Stop Phase, will be back to initial state and clear FIFO.

*Note: If timeout is not generated by Master, the response is in FIFO Clear Finished Event in Master Status Register.*

**Bit 5: Master Almost Full Event**

Indicate that Master generate Almost Full Event. It occurs only up to Almost Full level.

**Bit 4: Master Almost Empty Event**

Indicate that Master generate Almost Empty Event. It occurs only down to Almost Empty level.

**Bit 3: Master FIFO Data Write Error Event**

Indicate that Microprocessor writes to Master FIFO, Master FIFO is full or Read Mode.

**Bit 2: NACK Received Event**

Indicate that Master receives NACK. After generating Stop Phase, Master will be back to initial state and clear FIFO.

*Note: Wait for the response of Clear Finished Event in Master Status Register to start next transfer.*

**Bit 1: Bus Arbitration Failed Event**

Indicate that bus arbitration failed. Master will be back to initial state and clear FIFO.

**Bit 0: FIFO Clear Finished Event**

Indicate that Master finishes the request to clear FIFO.

*Note: When Micro Processors has not proposed Master FIFO Clear Request but produces, it indicates the remote device to drive SCL low to generate timeout.*

**6.4.1.8 Master FIFO Status Register (SM1/2MFIFOSTS) (Default Value: 0100\_0000)****Bit 7: Full Flag****Bit 6: Empty Flag****Bit 5~4: Reserved****Bit 3~0: FIFO Data Length**





## 6.5 Internal Interrupt Controller Block

W83L951DG/FG Interrupts occur by 28 sources, 27 external and 25 internal interrupt.

About Interrupt Control, each interrupt is controlled and corresponding to a bit in Interrupt Enable Register (IE1/2/3/4), the Interrupt Priority Control Register (IP1/2/3/4) and the Interrupt Request Register (IREQ1/2/3/4).

An interrupt occurs if the corresponding Interrupt Request occurs and enable bits is HIGH. When several interrupts occur at the same time, the interrupts are received according to priority setting. If interrupts are setting to same priority, then it is decided by hardware internal checking rule.

After Interrupt of EXTINT1, EXTINT2, EXTINT3, SMBUS1, SMBUS2, FAN1 and FAN2 is produced, can't be interrupt by other Interrupt source, so should set as High Propriety.

Table 6-11 Internal Interrupt Controller Register Define

| INTERRUPT BLOCK(17) |       |        |        |        |        |        |        |         |         |
|---------------------|-------|--------|--------|--------|--------|--------|--------|---------|---------|
| INTADDR             | NAME  | 7      | 6      | 5      | 4      | 3      | 2      | 1       | 0       |
| E1                  | IE1   | TimerY | TimerX | Timer2 | Timer1 | OBE1   | IBF1   | OBE0    | IBF0    |
| E2                  | IE2   | CNTR1  | CNTR0  | ADC    | RTC    | KEY-WP | EXINT3 | EXTINT2 | EXTINT1 |
| E3                  | IE3   | FAN2   | FAN1   | CIR    | APS2   | MPS2   | KPS2   | SMBUS2  | SMBUS1  |
| E4                  | IE4   | R      | R      | R      | R      | R      | R      | UARTRX  | UARTTX  |
| E9                  | IREQ1 | TimerY | TimerX | Timer2 | Timer1 | OBE1   | IBF1   | OBE0    | IBF0    |
| EA                  | IREQ2 | CNTR1  | CNTR0  | ADC    | RTC    | KEY-WP | EXINT3 | EXTINT2 | EXTINT1 |
| EB                  | IREQ3 | FAN2   | FAN1   | CIR    | APS2   | MPS2   | KPS2   | SMBUS2  | SMBUS1  |
| EC                  | IREQ4 | R      | R      | R      | R      | R      | R      | UARTRX  | UARTTX  |
| F1                  | IPRO1 | TimerY | TimerX | Timer2 | Timer1 | OBE1   | IBF1   | OBE0    | IBF0    |
| F2                  | IPRO2 | CNTR1  | CNTR0  | ADC    | RTC    | KEY-WP | EXINT3 | EXTINT2 | EXTINT1 |
| F3                  | IPRO3 | FAN2   | FAN1   | CIR    | APS2   | MPS2   | KPS2   | SMBUS2  | SMBUS1  |
| F4                  | IPRO4 | R      | R      | R      | R      | R      | R      | UARTRX  | UARTTX  |



Table 6-12 Internal Interrupt Vector & Trigger Type Table

| SOURCE                          | VECTOR ADDRESS | TRIGGER TYPE  |
|---------------------------------|----------------|---------------|
| Non-mask Interrupt              | 0x0003         | Edge Trigger  |
| LPC Power Fail Interrupt        | 0x000b         | Edge Trigger  |
| Input Buffer 0 Full Interrupt   | 0x0013         | Edge Trigger  |
| Output Buffer 0 Empty Interrupt | 0x001b         | Edge Trigger  |
| Input Buffer 1 Full Interrupt   | 0x0023         | Edge Trigger  |
| Output Buffer 1 Empty Interrupt | 0x002b         | Edge Trigger  |
| Timer 1 Interrupt               | 0x0033         | Edge Trigger  |
| Timer 2 Interrupt               | 0x003b         | Edge Trigger  |
| Timer X Interrupt               | 0x0043         | Edge Trigger  |
| Timer Y Interrupt               | 0x004b         | Edge Trigger  |
| External Interrupt Group 1      | 0x0053         | Level Trigger |
| External Interrupt Group 2      | 0x005b         | Level Trigger |
| External Interrupt Group 3      | 0x0063         | Level Trigger |
| Key Interrupt                   | 0x006b         | Edge Trigger  |
| Real Time Clock Alarm Interrupt | 0x0073         | Edge Trigger  |
| ADC Interrupt                   | 0x007b         | Edge Trigger  |
| CNTR0 Interrupt                 | 0x0083         | Edge Trigger  |
| CNTR1 Interrupt                 | 0x008b         | Edge Trigger  |
| SMBUS 1 Interrupt               | 0x0093         | Level Trigger |
| SMBUS 2 Interrupt               | 0x009b         | Level Trigger |
| Keyboard PS2 Interrupt          | 0x00a3         | Edge Trigger  |
| Mouse PS2 Interrupt             | 0x00ab         | Edge Trigger  |
| Auxiliary PS2 Interrupt         | 0x00b3         | Edge Trigger  |
| CIR Interrupt                   | 0x00bb         | Edge Trigger  |
| FAN 1 Interrupt                 | 0x00c3         | Level Trigger |
| FAN 2 Interrupt                 | 0x00cb         | Level Trigger |
| UART Tx Interrupt               | 0x00d3         | Edge Trigger  |
| UART Rx Interrupt               | 0x00db         | Edge Trigger  |
| Reserved                        | 0x00e3         | N/A           |
| Reserved                        | 0x00eb         | N/A           |
| Reserved                        | 0x00f3         | N/A           |
| Reserved                        | 0x00fb         | N/A           |

## 6.5.1 Register Description

### 6.5.1.1 Interrupt Enable 1 Register (IE1) (Default Value: 0000\_0000)

- 1: Enable. It produces Interrupt Request to Micro-Processor that Interrupt will be produced, and write down in Interrupt Request 1 Register.
- 0: Disable. It does not produce Interrupt Request to Micro-Processor that Interrupt will be produced, but write down in Interrupt Request 1 Register.

### 6.5.1.2 Interrupt Enable 2 Register (IE2) (Default Value: 0000\_0000)

- 1: Enable. It produces Interrupt Request to Micro-Processor that Interrupt will be produced, and write down in Interrupt Request 2 Register.



0: Disable. It does not produce Interrupt Request to Micro-Processor that Interrupt will be produced, but write down in Interrupt Request 2 Register.

### **6.5.1.3 Interrupt Enable 3 Register (IE3) (Default Value: 0000\_0000)**

1: Enable. It produces Interrupt Request to Micro-Processor that Interrupt will be produced, and write down in Interrupt Request 3 Register.

0: Disable. It does not produce Interrupt Request to Micro-Processor that Interrupt will be produced, but write down in Interrupt Request 3 Register.

### **6.5.1.4 Interrupt Enable 4 Register (IE4) (Default Value: 0000\_0000)**

1: Enable. It produces Interrupt Request to Micro-Processor that Interrupt will be produced, and write down in Interrupt Request 4 Register.

0: Disable. It does not produce Interrupt Request to Micro-Processor that Interrupt will be produced, but write down in Interrupt Request 4 Register.

### **6.5.1.5 Interrupt Request 1 Register (IREQ1) (Default Value: 0000\_0000)**

#### **Read:**

1: Requested

0: No Requested

#### **Write:**

1: Clear

0: No Change

### **6.5.1.6 Interrupt Request 2 Register (IREQ2) (Default Value: 0000\_0000)**

#### **Read:**

1: Requested

0: No Requested

#### **Write:**

1: Clear

0: No Change



## **6.5.1.7 Interrupt Request 3 Register (IREQ3) (Default Value: 0000\_0000)**

### **Read:**

1: Requested

0: No Requested

### **Write:**

1: Clear

0: No Change

## **6.5.1.8 Interrupt Request 4 Register (IREQ4) (Default Value: 0000\_0000)**

### **Read:**

1: Requested

0: No Requested

### **Write:**

1: Clear

0: No Change

## **6.5.1.9 Interrupt Priority 1 Register (IPRO1) (Default Value: 0000\_0000)**

1: High Priority

0: Low Priority

## **6.5.1.10 Interrupt Priority 2 Register (IPRO2) (Default Value: 0000\_0000)**

1: High Priority

0: Low Priority

## **6.5.1.11 Interrupt Priority 3 Register (IPRO3) (Default Value: 0000\_0000)**

1: High Priority

0: Low Priority

## **6.5.1.12 Interrupt Priority 4 Register (IPRO4) (Default Value: 0000\_0000)**

1: High Priority

0: Low Priority



## 6.6 GPIOs Block

W83L951DG/FG provides 13 GPIO blocks, and every GPIO block has 8 GPIO that can set individually. I/O Pad has three states by data register and direction register setting. Input register always reads current pad status.

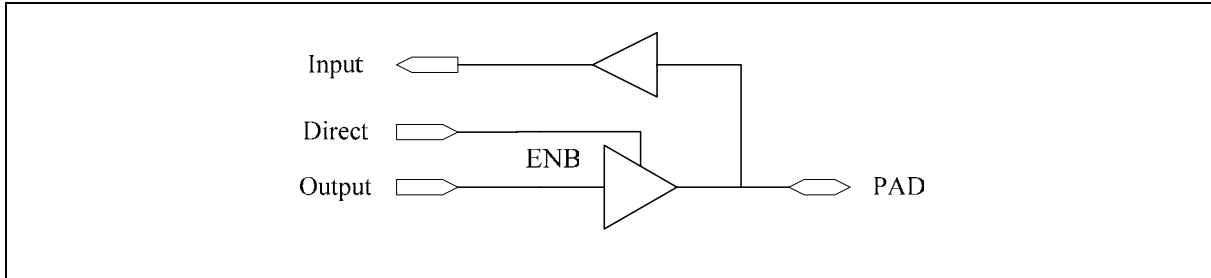

Figure 6-1 GPIO Block Diagram

Table 6-13 GPIOs Type Setup Define

| TYPE       | OUTPUT REGISTER(WRITE) | DIRECTION REGISTER |
|------------|------------------------|--------------------|
| Input      | Don't Care             | 0                  |
| Output     | Output Data            | 1                  |
| Open-Drain | 0                      | Output Data'       |

Table 6-14. GPIOs Control Register Define

| GPIO BLOCK(26) |       |                                   |   |   |   |   |   |   |   |
|----------------|-------|-----------------------------------|---|---|---|---|---|---|---|
| INTADDR        | NAME  | 7                                 | 6 | 5 | 4 | 3 | 2 | 1 | 0 |
| 80             | GPIO0 | GPIO 0 Input/Output Register[7:0] |   |   |   |   |   |   |   |
| 88             | GPIO1 | GPIO 1 Input/Output Register[7:0] |   |   |   |   |   |   |   |
| 90             | GPIO2 | GPIO 2 Input/Output Register[7:0] |   |   |   |   |   |   |   |
| 98             | GPIO3 | GPIO 3 Input/Output Register[7:0] |   |   |   |   |   |   |   |
| A0             | GPIO4 | GPIO 4 Input/Output Register[7:0] |   |   |   |   |   |   |   |
| A8             | GPIO5 | GPIO 5 Input/Output Register[7:0] |   |   |   |   |   |   |   |
| B0             | GPIO6 | GPIO 6 Input/Output Register[7:0] |   |   |   |   |   |   |   |
| B8             | GPIO7 | GPIO 7 Input/Output Register[7:0] |   |   |   |   |   |   |   |
| C0             | GPIO8 | GPIO 8 Input/Output Register[7:0] |   |   |   |   |   |   |   |
| C8             | GPIO9 | GPIO 9 Input/Output Register[7:0] |   |   |   |   |   |   |   |
| D8             | GPIOA | GPIO A Input/Output Register[7:0] |   |   |   |   |   |   |   |
| E8             | GPIOB | GPIO B Input/Output Register[7:0] |   |   |   |   |   |   |   |
| F8             | GPIOC | GPIO C Input/Output Register[7:0] |   |   |   |   |   |   |   |



Continued.

| GPIO BLOCK(26) |       |                                |   |   |   |   |   |   |   |
|----------------|-------|--------------------------------|---|---|---|---|---|---|---|
| INTADDR        | NAME  | 7                              | 6 | 5 | 4 | 3 | 2 | 1 | 0 |
| D1             | GIOD0 | GPIO 0 Direction Register[7:0] |   |   |   |   |   |   |   |
| D2             | GIOD1 | GPIO 1 Direction Register[7:0] |   |   |   |   |   |   |   |
| D3             | GIOD2 | GPIO 2 Direction Register[7:0] |   |   |   |   |   |   |   |
| D4             | GIOD3 | GPIO 3 Direction Register[7:0] |   |   |   |   |   |   |   |
| D5             | GIOD4 | GPIO 4 Direction Register[7:0] |   |   |   |   |   |   |   |
| D6             | GIOD5 | GPIO 5 Direction Register[7:0] |   |   |   |   |   |   |   |
| D7             | GIOD6 | GPIO 6 Direction Register[7:0] |   |   |   |   |   |   |   |
| D9             | GIOD7 | GPIO 7 Direction Register[7:0] |   |   |   |   |   |   |   |
| DA             | GIOD8 | GPIO 8 Direction Register[7:0] |   |   |   |   |   |   |   |
| DB             | GIOD9 | GPIO 9 Direction Register[7:0] |   |   |   |   |   |   |   |
| DC             | GIODA | GPIO A Direction Register[7:0] |   |   |   |   |   |   |   |
| DD             | GIODB | GPIO B Direction Register[7:0] |   |   |   |   |   |   |   |
| DE             | GIODC | GPIO C Direction Register[7:0] |   |   |   |   |   |   |   |

## 6.6.1 GPIO Data Register Description

### 6.6.1.1 GPIO 0 Input/Output Register (GPIO0) (Default Value: 0000\_0000)

**Write:**

Output data register

**Read:**

GPIO pin status whether GPIO function is active or not.

*Note: bit command and byte command have same result.*

*For example "CPL Bit" Instruction*

*Read Pin Status into temp Register.*

*Invert temp register.*

*Write Result to Output Data Register according for bit address, and not influence the value of other bit.*

### 6.6.1.2 GPIO 1 Input/Output Register (GPIO1) (Default Value: 0000\_0000)

**Write:**

Output data register

**Read:**

GPIO pin status whether GPIO function is active or not.

*Note: bit command and byte command have same result*



## 6.6.1.3 GPIO 2 Input/Output Register (GPIO2) (Default Value: 0000\_0000)

### Write:

Output data register

### Read:

GPIO pin status whether GPIO function is active or not.

*Note: bit command and byte command have same result*

## 6.6.1.4 GPIO 3 Input/Output Register (GPIO3) (Default Value: 0000\_0000)

### Write:

Output data register

### Read:

GPIO pin status whether GPIO function is active or not.

*Note: bit command and byte command have same result*

## 6.6.1.5 GPIO 4 Input/Output Register (GPIO4) (Default Value: 0000\_0000)

### Write:

Output data register

### Read:

GPIO pin status whether GPIO function is active or not.

*Note: bit command and byte command have same result*

## 6.6.1.6 GPIO 5 Input/Output Register (GPIO5) (Default Value: 0000\_0000)

### Write:

Output data register

### Read:

GPIO pin status whether GPIO function is active or not.

*Note: bit command and byte command have same result*

## 6.6.1.7 GPIO 6 Input/Output Register (GPIO6) (Default Value: 0000\_0000)

### Write:

Output data register

### Read:

GPIO pin status whether GPIO function is active or not.

*Note: bit command and byte command have same result*



## **6.6.1.8 GPIO 7 Input/Output Register (GPIO7) (Default Value: 0000\_0000)**

### **Write:**

Output data register

### **Read:**

GPIO pin status whether GPIO function is active or not.

Note: bit command and byte command have same result

## **6.6.1.9 GPIO 8 Input/Output Register (GPIO8) (Default Value: 0000\_0000)**

### **Write:**

Output data register

### **Read:**

GPIO pin status whether GPIO function is active or not.

Note: bit command and byte command have same result

## **6.6.1.10 GPIO 9 Input/Output Register (GPIO9) (Default Value: 0000\_0000)**

### **Write:**

Output data register

### **Read:**

GPIO pin status whether GPIO function is active or not.

Note: bit command and byte command have same result

## **6.6.1.11 GPIO A Input/Output Register (GPIOA) (Default Value: 0000\_0000)**

### **Write:**

Output data register

### **Read:**

GPIO pin status whether GPIO function is active or not.

Note: bit command and byte command have same result

## **6.6.1.12 GPIO B Input/Output Register (GPIOB) (Default Value: 0000\_0000)**

### **Write:**

Output data register

### **Read:**

GPIO pin status whether GPIO function is active or not.

Note: bit command and byte command have same result





## **6.6.1.13 GPIO C Input/Output Register (GPIOC) (Default Value: 0000\_0000)**

### **Write:**

Output data register

### **Read:**

GPIO pin status whether GPIO function is active or not.

Note: bit command and byte command have same result

## **6.6.2 GPIO Direction Register Description**

### **6.6.2.1 GPIO 0 Direction Register (GPIOD0) (Default Value: 0000\_0000)**

1: Output,

0: Input.

### **6.6.2.2 GPIO 1 Direction Register (GPIOD1) (Default Value: 0000\_0000)**

1: Output,

0: Input.

### **6.6.2.3 GPIO 2 Direction Register (GPIOD2) (Default Value: 0000\_0000)**

1: Output,

0: Input.

### **6.6.2.4 GPIO 3 Direction Register (GPIOD3) (Default Value: 0000\_0000)**

1: Output,

0: Input.

### **6.6.2.5 GPIO 4 Direction Register (GPIOD4) (Default Value: 0000\_0000)**

1: Output,

0: Input.

### **6.6.2.6 GPIO 5 Direction Register (GPIOD5) (Default Value: 0000\_0000)**

1: Output,

0: Input.

### **6.6.2.7 GPIO 6 Direction Register (GPIOD6) (Default Value: 0000\_0000)**

1: Output,

0: Input.



**6.6.2.8 GPIO 7 Direction Register (GPIOD7) (Default Value: 0000\_0000)**

1: Output,  
0: Input.

**6.6.2.9 GPIO 8 Direction Register (GPIOD8) (Default Value: 0000\_0000)**

1: Output,  
0: Input.

**6.6.2.10 GPIO 9 Direction Register (GPIOD9) (Default Value: 0000\_0000)**

1: Output,  
0: Input.

**6.6.2.11 GPIO A Direction Register (GPIODA) (Default Value: 0000\_0000)**

1: Output,  
0: Input.

**6.6.2.12 GPIO B Direction Register (GPIODB) (Default Value: 0000\_0000)**

1: Output,  
0: Input.

**6.6.2.13 GPIO C Direction Register (GPIODC) (Default Value: 0000\_0000)**

1: Output,  
0: Input.



## 6.7 Watch Dog Block

The watchdog timer gives a mean of returning to the reset state when a program cannot run on a normal loop (for example, because of a software run-away). The watchdog timer consists of an 8-bit timer L and an 8-bit timer H. At reset or writing to the watchdog timer control register WDTCON [7] (START), each watchdog timer H and L is set to 0FFh.

About Watchdog timer H count size selection, we can use Bit 5 of the watchdog timer control register (SIZE) permits selecting a watchdog timer H count source. When this bit is set to LOW, the count source becomes the underflow signal of watchdog timer L.

Table 6-15. Watch Dog Register Define

| WATCH DOG BLOCK(1) |        |          |         |      |                            |   |   |   |      |  |
|--------------------|--------|----------|---------|------|----------------------------|---|---|---|------|--|
| EXTADDR            | NAME   | 7        | 6       | 5    | 4                          | 3 | 2 | 1 | 0    |  |
| 00                 | WDTCON | START    | INTTYPE | SIZE | Clock Prescale Number[4:0] |   |   |   |      |  |
| 01                 | WDTSTS | Reserved |         |      |                            |   |   |   | +WDT |  |

**Gray:** Only with System Reset (Pin Reset + WDT Reset) to Initial.

+: Only with Pin Reset to Initial

### 6.7.1 Register Description

#### 6.7.1.1 Watch Dog Control Register (WDTCON) (Default Value: 0000\_0000)

Reset with Power Reset & Pin Reset.

##### Bit 7: Start

1: Start / Reload

0: Stop

This Bit permits enable/disable the watchdog timer. Write LOW to this bit, the watchdog timer is stopped. Write HIGH to this bit will reload the watchdog timer (watchdog timer H and L is set to 0FFh) even this bit is already be HIGH. After written HIGH, the watchdog timer is running. Once this timer is timed-out the chip is reset. Also the watchdog timer is stopped to prevent the next time-out.

##### Bit 6: Interrupt Type

1: NMI

0: Hardware reset

##### Bit 5: Size

Select the counter size. The counter starts from low to overflow. Then generate interrupt or hardware reset.

1: One Byte Counter. WDT Timeout Limit  $\approx 256/\text{Count Frequency}$

0: Two Byte Counter. WDT Timeout Limit  $\approx 65536/\text{Count Frequency}$



**Bit 4~0: Clock Prescale Number**

Input clock=24MHz : Count frequency is 1MHz / 2(Clock Prescale Number +1).

Input clock=12MHz : Count frequency is 1MHz / 4(Clock Prescale Number +1).

**6.7.1.2 Watch Dog Status Register (WDTSTS) (Default Value: 0000\_0000)**

Reset with Power Reset.

**Bit 7~1: Reserved**

**Bit 0: WDT Reset Finished**

1: Finished, 0: No Happened.



## 6.8 Timer Block

The Keyboard controller has four timers: timer X, timer Y, timer 1, and timer 2. The division ratio of each timer or pre-scalar is given by  $1/n + 1$ , where n is the value in the corresponding timer or pre-scalar latch. All timers are count down. When the timer reaches "00H", an underflow occurs at the next count pulse and the corresponding timer latch is reloaded into the timer and the count is continued. When a timer is underflow, the corresponding interrupt request bit is set to 1.

In Timer 1 and Timer 2, the count source of pre-scalar 1/2 is the oscillator frequency divided by 16. The output of pre-scalar 1/2 is counted for both timer 1 and 2, and a timer underflow sets the interrupt request bit.

Timer X and Timer Y can works in one of four operating modes by setting the timer XY mode register.

Table 6-16.Timer Register Define

| TIMER BLOCK(9) |      |                  |                  |         |       |       |         |   |   |  |
|----------------|------|------------------|------------------|---------|-------|-------|---------|---|---|--|
| EXTADDR        | NAME | 7                | 6                | 5       | 4     | 3     | 2       | 1 | 0 |  |
| 10             | PRE1 | TM1ST            | Prescale 1 [6:0] |         |       |       |         |   |   |  |
| 11             | T1   | Timer 1 [7:0]    |                  |         |       |       |         |   |   |  |
| 12             | PRE2 | TM2ST            | Prescale 2 [6:0] |         |       |       |         |   |   |  |
| 13             | T2   | Timer 2 [7:0]    |                  |         |       |       |         |   |   |  |
| 18             | TM   | TMYST            | CNTR1            | TMYMODE | TMXST | CNTR0 | TMXMODE |   |   |  |
| 19             | PREX | Prescale X [7:0] |                  |         |       |       |         |   |   |  |
| 1A             | TX   | Timer X[7:0]     |                  |         |       |       |         |   |   |  |
| 1B             | PREY | Prescale Y [7:0] |                  |         |       |       |         |   |   |  |
| 1C             | TY   | Timer Y [7:0]    |                  |         |       |       |         |   |   |  |

### 6.8.1 Register Description

#### 6.8.1.1 Clock Prescale Number of Timer 1 (PRE1) (Default Value: 0111\_1111)

##### Bit 7: Timer 1 Start Bit

Write: Start Timer 1 counter.

1: Enable (Prescale Counter Reload & Start, but Timer 1 Data Keep)

0: Disable

Read: Always Read 'LOW'.



## **Bit 6~0: Clock Prescale Number**

Write: Prescale Counter Reload.

Read: Current Prescale Counter Value

### **6.8.1.2 Timer 1 Register (T1) (Default Value: 1111\_1111)**

#### **Bit 7~0:**

Write: Timer 1 Counter Reload.

Read: Current Timer 1 Counter Value

Note: In writing, due to the effect of internal frequency XIN/16, 0~16 system clock error occurs in first prescale period width.

### **6.8.1.3 Clock Prescale Number of Timer 2 (PRE2) (Default Value: 0111\_1111)**

#### **Bit 7: Timer 2 Start Bit**

1: Start (Prescale Counter Reload & Start, but Timer 2 Data Keep)

0: Stop

#### **Bit 6~0: Clock Prescale Number**

Write: Prescale Counter Reload.

### **6.8.1.4 Timer 2 Register (T2) (Default Value: 1111\_1111)**

#### **Bit 7~0:**

Write: Timer 2 Reload.

Note: In writing, due to the effect of internal frequency XIN/16, 0~16 system clock error occurs in first prescale period width.

### **6.8.1.5 Timer X/Y Mode Register (TM) (Default Value: 0000\_0000)**

#### **Bit 7: Timer Y Start Bit**

Start internal Time Y counter and

1: Enable (Prescale Y & Timer Y Data Keep after Stop)

0: Disable

#### **Bit 6: CNTR1 active edge selection bit**

0: Interrupt at falling edge Count at rising edge in event counter mode.

1: Interrupt at rising edge Count at falling edge in event counter mode.

#### **Bit 5-4: Timer Y operating bit**

00: Timer mode

The Timer Y can select the count by XIN/16.

01: Pulse output mode (Disable GP83 Function, Pin Direct Force "Output")

Timer Y counts XIN/16. Whenever the contents of the timer reach "00H", the signal output from the CNTR1 pin is inverted. If the CNTR1 active edge selection bit is 0, the pin is "H" after initial. If it is 1, the pin is 'L' after initial. When using a timer in this mode, set the corresponding direction register of port GP83 to output mode.

10: Event count mode (Disable GP83 Function, Pin Direct Force "Input")



Operating on event counter mode is the almost same as in timer mode, except that the timer counts signals input through the CNTR1. When the CNTR1 active edge selection bit is 0, the rising edge on the CNTR1 pin is counted. When the CNTR1 active edge selection bit is 1, the falling edge on the CNTR1 pin is counted.

11: Pulse width measurement mode (Disable GP83 Function, Direct Force "Input")

If the CNTR1 active edge selection bit is 0, the timer counts  $XIN/16$  while the CNTR1 pin is H. If the CNTR1 active edge selection bit is 1, the timer counts while the CNTR1 pin is 'L'.

### **Bit 3: Timer X Start Bit**

1: Enable (Prescale X & Timer X Data Keep)

0: Disable

### **Bit 2: CNTR0 active edge selection bit**

0: Interrupt at falling edge Count at rising edge in event counter mode.

1: Interrupt at rising edge Count at falling edge in event counter mode.

### **Bit 1-0: Timer X operating bit**

00: Timer mode

The Timer X only counts  $XIN/16$ .

01: Pulse output mode (Disable GP82 Function, Direct Force "Output")

Timer X counts  $XIN/16$ . Whenever the contents of the timer reach "00H", the signal output from the CNTR0 pin is inverted. If the CNTR0 active edge selection bit is 0, the pin is "H" after initial. If it is 1, the pin is 'L' after initial. When using a timer in this mode, set the corresponding direction register of port GP82 to output mode.

10: Event count mode (Disable GP82 Function, Direct Force "Input")

Operating on event counter mode is the almost same as in timer mode, except that the timer counts signals input through the CNTR0. When the CNTR0 active edge selection bit is 0, the rising edge on the CNTR0 pin is counted. When the CNTR0 active edge selection bit is 1, the falling edge on the CNTR0 pin is counted.

11: Pulse width measurement mode (Disable GP82 Function, Direct Force "Input")

If the CNTR0 active edge selection bit is 0, the timer counts  $XIN/16$  while the CNTR0 pin is H. If the CNTR0 active edge selection bit is 1, the timer counts while the CNTR0 pin is 'L'.

*Note: The count can be stopped by setting a "0" to the timer X (or timer Y) count start bit in any mode. The corresponding interrupt request bit is set each time a timer underflows.*

## **6.8.1.6 Clock Prescale Number of Timer X (PREX) (Default Value: 1111\_1111)**

### **Bit 7~0: Clock Prescale Number**

Write: Prescale Counter Reload.

Read: Current Prescale Counter Value

Note: In writing, due to the effect of internal frequency  $XIN/16$ , 0~16 system clock error occurs in first prescale period width.



## **6.8.1.7 Timer X Register (TX) (Default Value: 1111\_1111)**

### **Bit 7~0:**

Write: Timer X Reload.

Read: Current Timer X Counter Value

Note: In writing, due to the effect of internal frequency  $XIN/16$ , 0~16 system clock error occurs in first prescale period width.

## **6.8.1.8 Clock Prescale Number of Timer Y (PREY) (Default Value: 1111\_1111)**

### **Bit 7~0: Clock Prescale Number**

Write: Prescale Counter Reload.

Note: In writing, due to the effect of internal frequency  $XIN/16$ , 0~16 system clock error occurs in first prescale period width.

Read: Current Prescale Counter Value

## **6.8.1.9 Timer Y Register (TY) (Default Value: 1111\_1111)**

### **Bit 7~0:**

Write: Timer Y Reload.

Read: Current Timer X Counter Value





## 6.9 Pulse Width Modulator Block

W83L 951D provides 4 Pulse Width Modulator Output.

8-bit PWM has two: PWM1 and PWM2. The fixed resolution is about 64us(Input clock=24MHz) or 128us(Input clock=12MHz).

16-bit PWM has two: PWM3 and PWM4. The minimum resolution can be selected by frequency select in PWM Control Register.

Table 6-17.Pulse Width Modulator Register Define

| PULSE WIDTH MEASURER BLOCK(13) |        |                                  |                   |   |          |   |                   |   |   |
|--------------------------------|--------|----------------------------------|-------------------|---|----------|---|-------------------|---|---|
| EXTADDR                        | NAME   | 7                                | 6                 | 5 | 4        | 3 | 2                 | 1 | 0 |
| 20                             | PWMCON | Reserved                         | PWM4 Freq. Select |   | Reserved |   | PWM3 Freq. Select |   |   |
| 21                             | PWM1P  | PWM 1 Period Register [7:0]      |                   |   |          |   |                   |   |   |
| 22                             | PWM1H  | PWM 1 High Level Register [7:0]  |                   |   |          |   |                   |   |   |
| 23                             | PWM2P  | PWM 2 Period Register [7:0]      |                   |   |          |   |                   |   |   |
| 24                             | PWM2H  | PWM 2 High Level Register [7:0]  |                   |   |          |   |                   |   |   |
| 25                             | PWM3PL | PWM 3 Period Register [7:0]      |                   |   |          |   |                   |   |   |
| 26                             | PWM3PH | PWM 3 Period Register [15:8]     |                   |   |          |   |                   |   |   |
| 27                             | PWM3HL | PWM 3 High Level Register [7:0]  |                   |   |          |   |                   |   |   |
| 28                             | PWM3HH | PWM 3 High Level Register [15:8] |                   |   |          |   |                   |   |   |
| 29                             | PWM4PL | PWM 4 Period Register [7:0]      |                   |   |          |   |                   |   |   |
| 2A                             | PWM4PH | PWM 4 Period Register [15:8]     |                   |   |          |   |                   |   |   |
| 2B                             | PWM4HL | PWM 4 High Level Register [7:0]  |                   |   |          |   |                   |   |   |
| 2C                             | PWM4HH | PWM 4 High Level Register [15:8] |                   |   |          |   |                   |   |   |

Gray: Only with System Reset to initial.

Note:

If {PWM High Level Register} = 0, the output keeps in low level.

If {PWM High Level Register} >= {PWM Period Register}, the PWM1/PWM2 output will keep in high level with 1us low pulse, PWM3/PWM4 output will keep in high level without pulse.

If PWM1/PWM2 is {PWM Period Level Register} > {PWM High Level Register} > 0, then

Period Width:  $64 \times \{PWM\ Period\ Level\ Register\} + 4units.$

Low Width :  $64 \times (\{PWM\ Period\ Level\ Register\} - \{PWM\ High\ Level\ Register\}) + 1unit.$

High Width :  $64 \times \{PWM\ High\ Level\ Register\} + 3 units.$



*The unit is 1us in PWM1/PWM2.*

*PWM 3/PWM4 is {PWM Period Level Register} > {PWM High Level Register} >0, then*

*Period Width: {PWM Period Level Register} + 4units.*

*Low Width : {PWM Period Level Register} – {PWM High Level Register} + 1unit.*

*High Width : {PWM High Level Register} + 3units.*

*The unit is 1/F in PWM 3/PWM4. And F is defined in PWM Control Register.*

*PWM 1/PWM2/PWM3/PWM4 is default low.*

## 6.9.1 Register Description

### 6.9.1.1 PWM Control Register (PWMCON) (Default Value: 0000\_0000)

**Bit 7: Reserved**

**Bit 6~4: PWM 4 Frequency Select**

Input clock=24MHz :

111: Reserved, 110: 375 KHz, 101: 750 KHz, 100: 1.5 MHz.

011: 3 MHz, 010: 6 MHz, 001: 12 MHz, 000: 24 MHz.

Input clock=12MHz :

111: Reserved, 110: Reserved, 101: 375 KHz, 100: 750KHz.

011: 1.5 MHz, 010: 3 MHz, 001: 6 MHz, 000: 12 MHz.

**Bit 3: Reserved**

**Bit 2~0: PWM 3 Frequency Select**

Input clock=24MHz :

111: Reserved, 110: 375 KHz, 101: 750 KHz, 100: 1.5 MHz.

011: 3 MHz, 010: 6 MHz, 001: 12 MHz, 000: 24 MHz.

Input clock=12MHz :

111: Reserved, 110: Reserved, 101: 375 KHz, 100: 750KHz.

011: 1.5 MHz, 010: 3 MHz, 001: 6 MHz, 000: 12 MHz.

### 6.9.1.2 PWM 1 Period Register (PWM1P) (Default Value: 0000\_0000)

Use the 8-bit register to control width of a full period output.



## **6.9.1.3 PWM 2 Period Register (PWM2P) (Default Value: 0000\_0000)**

Use the 8-bit register to control width of a full period output.

## **6.9.1.4 PWM 3 Period Register (PWM3PH, PWM3PL) (Default Value: 0000h)**

Use the 16-bit register to control width of a full period output.

## **6.9.1.5 PWM 4 Period Register (PWM4PH, PWM4PL) (Default Value: 0000h)**

Use the 16-bit register to control width of a full period output.

## **6.9.1.6 PWM 1 High Level Register (PWM1H) (Default Value: 0000\_0000)**

PWM1H is defined as high signal width for PWM1 output. It is an 8-bit register.

## **6.9.1.7 PWM 2 High Level Register (PWM2H) (Default Value: 0000\_0000)**

PWM2H is defined as high signal width for PWM2 output. It is an 8-bit register.

## **6.9.1.8 PWM 3 High Level Register (PWM3HH, PWM3HL) (Default Value: 0000\_0000)**

(PWM3HH, PWM3HL) is defined as high signal width for PWM3 output. It is a 16-bit register.

## **6.9.1.9 PWM 4 High Level Register (PWM4HH, PWM4HL) (Default Value: 0000\_0000)**

(PWM4HH, PWM4HL) is defined as high signal width for PWM4 output. It is a 16-bit register.



## 6.10 UART Block

W83L951DG/FG supports one Universal asynchronous serial I/O mode (UART) .Eight serial data transfer formats can be selected, for vary selection of Stop bit, Parity, Parity check, Data length, and the transfer formats used by a transmitter and receiver must be identical.

The transmitter and receiver shift registers each have a buffer, but the two buffers have the same address in memory. Since the shift register cannot be written to or read from directly, transmit data is written to the transmit buffer register, and receive data is read from the receive buffer register. The transmit buffer register can also hold the next data to be transmitted, and the receive buffer register can hold a byte while the next byte is being received.

Table 6-18.UART Register Define

| UART Block(5) |         |                                     |          |         |          |      |      |         |          |
|---------------|---------|-------------------------------------|----------|---------|----------|------|------|---------|----------|
| ExtAddr       | Name    | 7                                   | 6        | 5       | 4        | 3    | 2    | 1       | 0        |
| 30            | UARTCON | TxEn                                | TS       | RxEn    | PARE     | PARS | STPS | CHAS    | Reserved |
| 31            | UARTSTS | ParErr                              | FrameErr | OverErr | Reserved |      |      | RxBFull | TxBFull  |
| 32            | BRGH    | Baud Rate Generator High Byte[7:0]  |          |         |          |      |      |         |          |
| 33            | BRGL    | Baud Rate Generator Low Byte[7:0]   |          |         |          |      |      |         |          |
| 34            | UARTBUF | UART Transmit / Receive Buffer[7:0] |          |         |          |      |      |         |          |

*Gray*: Only with System Reset to initial.

### 6.10.1 Register Description

#### 6.10.1.1 UART Control Register (UARTCON) (Default Value: 0000\_0000)

##### Bit 7: Transmit enable bit (TE)

0: Transmit disabled. 1: Transmit enable.

##### Bit 6: Transmit Speed up bit (TS) (Reserved)

0: Disable.

1: Enable.

##### Bit 5: Receive enable bit (RE)

0: Receive disable. 1: Receive enable.

##### Bit 4: Parity enable bit (PARE).

0: Parity Bit disable. 1: Parity Bit enable.

##### Bit 3: Parity selection bit (PARS).

0: Odd parity. 1: Even parity.

##### Bit 2: Stop bit length selection bit (STPS)

0: 1 stop bit. 1: 2 stop bits.



**Bit 1: Character length selection bit (CHAS) .**

0: 8 bits 1: 7 bits.

**Bit 0: User Define Register**

## 6.10.1.2 UART Status Register (UARTSTS) (Default Value: 0000\_0000)

**Bit 7: Parity Error Status for Packet at Receive Buffer (PE)**

Read: 0 - No error, 1 - Parity error

**Bit 6: Framing Error Status for Packet at Receive Buffer (FE)**

Read: 0 - No error, 1 - Framing error

**Bit 5: Overrun Error Interrupt (OE)**

For UART Rx Interrupt, users need to write this bit to clear.

Read:

0 - No error

1 - Overrun error

Write:

0 - No Chang

1 - Clear

**Bit 4~2: No use (return 'L' when read)**

**Bit 1: Receive Buffer Full Status Flag (RBF)**

Receive Buffer Full generates the interrupt. Read buffer can clear the flag.

0: Buffer empty

1: Buffer full

**Bit 0: Transmit Buffer Full Status Flag (TBF)**

Transmit Buffer Empty generates the interrupt. Write buffer can clear the flag. And next byte is allowed to write into the buffer.

0: Buffer empty

1: Buffer full



### **6.10.1.3 Baud Rate Generator High/Low Byte Register (BRGH/BRGL) (Default Value: 0000\_0000\_0000\_0000)**

Input clock=24MHz :

Baud Rate Period Width =  $(N+1) / 3\text{MHz}$ .

And N = {BRGH, BRGL}

Input clock=12MHz :

Baud Rate Period Width =  $2(N+1) / 3\text{MHz}$ .

And N = {BRGH, BRGL}

### **6.10.1.4 UART Transmit / Receive Buffer (UARTBUF) (Default Value: 0000\_0000)**

Read: Receive Buffer

Write: Transmit Buffer



## 6.11 Consumer Infrared Communications Receiver Block

The CIRC implements hardware-level decoding for the NEC Consumer IR Remote Control format. The hardware decoder may be used to generate a wake-up event or to send parts of the received message frame to the FIFO. The No Care Custom Code (NCCC), No Care Data Code (NCDC), PME Wake and Frame bits of the Consumer IR Control register configure the hardware decoder.

About NEC Consumer IR Format, the NEC Consumer IR Remote Control format specifies a 38 kHz carrier, 13ms of sync framing, and 32 bits of pulse-position modulated (PPM) message data. The message data includes an 8 bit Custom Code field, an 8 bit Custom Code' field, an 8 bit Data Code field, and an 8 bit Data Code' field. A single frame of the NEC PPM Consumer Remote Control signal is shown in Figure 14-1.

The Custom Code fields in this protocol uniquely address message frames for specific devices. The Custom Code fields can be used as a 16 bit address or as an 8 bit address followed by the bit-wise complement of the Custom Code field Custom Code. The Data Code field is an 8 bit command code, Data Code' is the bit-wise complement of Data Code.

Note: The CIRC hardware can decode NEC protocol framing (sync pulse, 32 bit PPM message data) at any data rate, depending on the programmed Bit Rate Divider (BRD).

Table 6-19. Consumer Infrared Communications Receiver Register Define

| CIR BLOCK(3) |          |                         |     |     |        |    |    |    |       |
|--------------|----------|-------------------------|-----|-----|--------|----|----|----|-------|
| EXTADDR      | NAME     | 7                       | 6   | 5   | 4      | 3  | 2  | 1  | 0     |
| 40           | CIRCON   | DFE                     | SFE | REP | FINISH | DM | SM | RM | RXINV |
| 41           | CIRBRD   | Baud Rate Divider[7:0]  |     |     |        |    |    |    |       |
| 42           | CIRDATA1 | CIR Receive Data 1[7:0] |     |     |        |    |    |    |       |
| 43           | CIRDATA2 | CIR Receive Data 2[7:0] |     |     |        |    |    |    |       |
| 44           | CIRDATA3 | CIR Receive Data 3[7:0] |     |     |        |    |    |    |       |
| 45           | CIRDATA4 | CIR Receive Data 4[7:0] |     |     |        |    |    |    |       |

*Gray: Only with System Reset to initial.*

### 6.11.1 Register Description

#### 6.11.1.1 CIR Configure Register (CIRCON) (Default Value: 0000\_0000)

##### Bit 7: Data Frame Error Status Flag (Write 'HIGH' to Clear)

When Data Frame Error flag occurs, CIR Interrupt is generated. Write the bit can clear Data Frame Error Flag.

Read:

- 0 - No error
- 1 - Data frame Error



Write:

- 0 - No Change
- 1 - Clear

**Bit 6: Start Frame Error Status Flag (Write 'HIGH' to Clear)**

When Start Frame Error flag occurs, CIR Interrupt is generated. Write the bit can clear Start Frame Error Flag.

Read:

- 0 - No error
- 1 - Start Frame Error

Write:

- 0 - No Change
- 1 - Clear

**Bit 5: Repeat Status Flag (Write 'HIGH' to Clear)**

When Repeat Flag occurs, CIR Interrupt is generated. Write the bit can clear Repeat Flag.

Read:

- 0 - No happened
- 1 - Repeat Packet Received.

Write:

- 0 - No Change
- 1 - Clear

**Bit 4: Finish Status Flag (Write 'HIGH' to Clear)**

When Finish Flag occurs, CIR Interrupt is generated. Write the bit can clear Finish Flag.

Read:

- 0 - No happened
- 1 - Packet Received is finish.

Write:

- 0 - No Chang
- 1 - Clear

**Bit 3: Data Frame Error Interrupt Mask Enable**

- 0 - Enable.
- 1 - Disable.

**Bit 2: Start Frame Error Interrupt Mask Enable**

- 0 - Enable.
- 1 - Disable.





## Bit 1: Repeat Interrupt Mask Enable

0 – Enable.

1 – Disable.

## Bit 0: Rx Signal Invert Enable

Enable CIR Rx signal Convert Function

0 – Enable.

1 – Disable.

### 6.11.1.2 Baud Rate Divider (CIRBRD) (Default Value: 0101\_0101)

Input clock=24MHz :

The Transmit and Receive Bit Rate Divider register is used to extract a serial NRZ data stream for the CIRC SCE. The divider is eight bits wide. The input clock to the Bit Rate Divider is 100 KHz (Carrier Frequency Divider input clock 16). The relationship between the Bit Rate Divider (BRD) and the Bit Rate (Fb) is as follows:

$$\text{BRD} = (.1\text{MHz}/\text{Fb}) - 1$$

For example, program the Bit Rate Divider with 55 ('37'Hex) for a .562ms Remote Control bit cell like for the NEC remote control frame format: Fb = 1.786 KHz. This is ~.5% accuracy. Table 9 contains representative BRD vs. BitRate relationships. The Bit Rate range is 100 KHz to 390.625Hz.

Input clock=12MHz :

The Transmit and Receive Bit Rate Divider register is used to extract a serial NRZ data stream for the CIRC SCE. The divider is eight bits wide. The input clock to the Bit Rate Divider is 50 KHz (Carrier Frequency Divider input clock 16). The relationship between the Bit Rate Divider (BRD) and the Bit Rate (Fb) is as follows:

$$\text{BRD} = (.05\text{MHz}/\text{Fb}) - 1$$

For example, program the Bit Rate Divider with 55 ('37'Hex) for a .562ms Remote Control bit cell like for the NEC remote control frame format: Fb = 0.893 KHz. This is ~.5% accuracy. Table 9 contains representative BRD vs. BitRate relationships. The Bit Rate range is 50 KHz to 190Hz.

# W83L951DG/W83L951FG

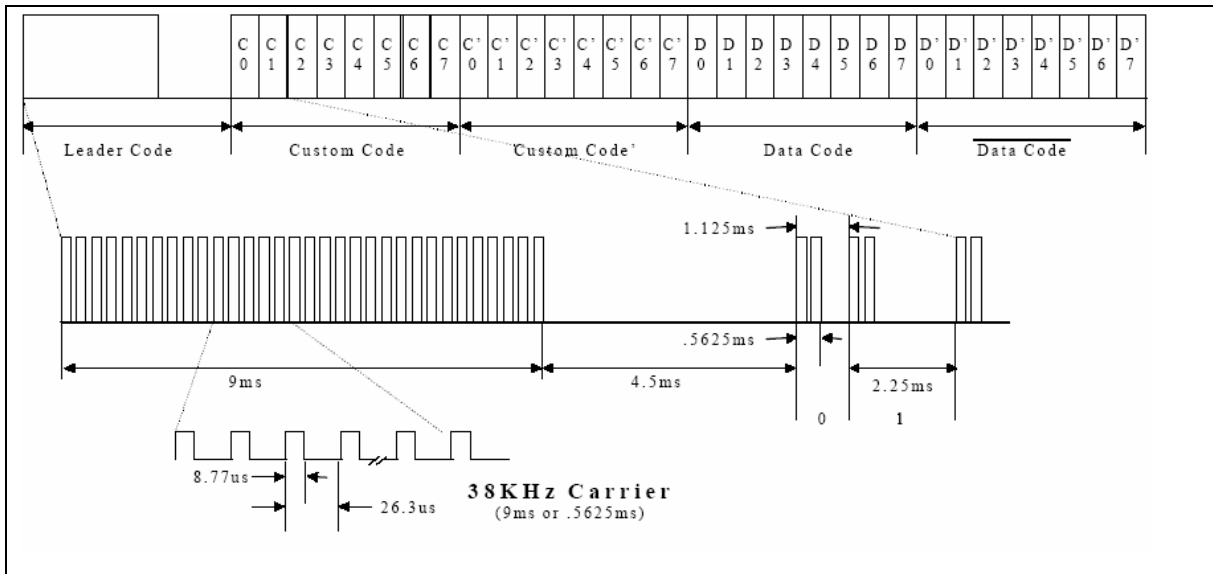

Figure 6-2.NEC CIR Frame Format

Table 6-20.Bit Rate Divider (BRD) V.S Bit Rate (Fb)

| INPUT CLOCK=12MHZ |          |     |          |     |          |     |          |
|-------------------|----------|-----|----------|-----|----------|-----|----------|
| BRD               | FB (KHZ) | BRD | FB (KHZ) | BRD | FB (KHZ) | BRD | FB (KHZ) |
| 003               | 12.5     | 067 | 0.7355   | 131 | 0.379    | 195 | 0.255    |
| 007               | 6.25     | 071 | 0.6945   | 135 | 0.3675   | 199 | 0.25     |
| 011               | 4.1665   | 075 | 0.658    | 139 | 0.357    | 203 | 0.245    |
| 015               | 3.125    | 079 | 0.625    | 143 | 0.347    | 207 | 0.2405   |
| 019               | 2.5      | 083 | 0.595    | 147 | 0.338    | 211 | 0.236    |
| 023               | 2.0835   | 087 | 0.568    | 151 | 0.329    | 215 | 0.2315   |
| 027               | 1.7855   | 091 | 0.5435   | 155 | 0.3205   | 219 | 0.2275   |
| 031               | 1.5625   | 095 | 0.521    | 159 | 0.3125   | 223 | 0.223    |
| 035               | 1.389    | 099 | 0.5      | 163 | 0.305    | 227 | 0.2195   |
| 039               | 1.25     | 103 | 0.481    | 167 | 0.2975   | 231 | 0.2155   |
| 043               | 1.1365   | 107 | 0.463    | 171 | 0.2905   | 235 | 0.212    |
| 047               | 1.0415   | 111 | 0.4465   | 175 | 0.284    | 239 | 0.2085   |
| 051               | 0.9615   | 115 | 0.431    | 179 | 0.278    | 243 | 0.205    |
| 055               | 0.893    | 119 | 0.4165   | 183 | 0.2715   | 247 | 0.2015   |
| 059               | 0.8335   | 123 | 0.403    | 187 | 0.266    | 251 | 0.1985   |
| 063               | 12.5     | 127 | 0.781    | 191 | 0.521    | 255 | 0.19     |

# W83L951DG/W83L951FG



Continued.

| INPUT CLOCK=24MHZ |          |     |          |     |          |     |          |
|-------------------|----------|-----|----------|-----|----------|-----|----------|
| BRD               | FB (KHZ) | BRD | FB (KHZ) | BRD | FB (KHZ) | BRD | FB (KHZ) |
| BRD               | Fb (kHz) | BRD | Fb (kHz) | BRD | Fb (kHz) | BRD | Fb (kHz) |
| 003               | 25.000   | 067 | 1.471    | 131 | 0.758    | 195 | 0.510    |
| 007               | 12.500   | 071 | 1.389    | 135 | 0.735    | 199 | 0.500    |
| 011               | 8.333    | 075 | 1.316    | 139 | 0.714    | 203 | 0.490    |
| 015               | 6.250    | 079 | 1.250    | 143 | 0.694    | 207 | 0.481    |
| 019               | 5.000    | 083 | 1.190    | 147 | 0.676    | 211 | 0.472    |
| 023               | 4.167    | 087 | 1.136    | 151 | 0.658    | 215 | 0.463    |
| 027               | 3.571    | 091 | 1.087    | 155 | 0.641    | 219 | 0.455    |
| 031               | 3.125    | 095 | 1.042    | 159 | 0.625    | 223 | 0.446    |
| 035               | 2.778    | 099 | 1.000    | 163 | 0.610    | 227 | 0.439    |
| 039               | 2.500    | 103 | 0.962    | 167 | 0.595    | 231 | 0.431    |
| 043               | 2.273    | 107 | 0.926    | 171 | 0.581    | 235 | 0.424    |
| 047               | 2.083    | 111 | 0.893    | 175 | 0.568    | 239 | 0.417    |
| 051               | 1.923    | 115 | 0.862    | 179 | 0.556    | 243 | 0.410    |
| 055               | 1.786    | 119 | 0.833    | 183 | 0.543    | 247 | 0.403    |
| 059               | 1.667    | 123 | 0.806    | 187 | 0.532    | 251 | 0.397    |
| 063               | 1.563    | 127 | 0.781    | 191 | 0.521    | 255 | 0.391    |

### 6.11.1.3 CIR Receive Data 1(CIRDATA1) (Default Value: 0000\_0000)

Read: CIR 1st Received Data Buffer

### 6.11.1.4 CIR Receive Data 1/2/3/4(CIRDATA1/2/3/4) (Default Value: 0000\_0000)

Read: CIR 2nd Received Data Buffer

### 6.11.1.5 CIR Receive Data 1/2/3/4(CIRDATA1/2/3/4) (Default Value: 0000\_0000)

Read: CIR 3rd Received Data Buffer

### 6.11.1.6 CIR Receive Data 1/2/3/4(CIRDATA1/2/3/4) (Default Value: 0000\_0000)

Read: CIR 4th Received Data Buffer



## 6.12 A/D Converter Block

W83L951DG/FG provides 8 A/D inputs. Analog input pin is selected in A/D Converter Register 0. The A-D conversion register is a read-only register that stores the result of an A-D conversion. When reading this register during an A-D conversion, the previous conversion result is read.

Table 6-21 A/D Convert Register Define

| A/D CONVERT BLOCK(4) |         |              |                     |     |      |          |              |     |     |
|----------------------|---------|--------------|---------------------|-----|------|----------|--------------|-----|-----|
| EXTADDR              | NAME    | 7            | 6                   | 5   | 4    | 3        | 2            | 1   | 0   |
| 50                   | AD1     | ADCST        | Analog Input Select |     | ADCC | Reserved | Analog [1:0] |     |     |
| 51                   | AD2     | Analog [9:2] |                     |     |      |          |              |     |     |
| 54                   | PADMODE | AD7          | AD6                 | AD5 | AD4  | AD3      | AD2          | AD1 | AD0 |

*Gray*: Only with System Reset to initial.

### 6.12.1 Register Description

A/D converter is 10-bit converter. The  $V_{REF}$  is Input of VREF pin.

The formula: A/D converter result = (Analog [9:0] / 1024) ×  $V_{REF}$

#### 6.12.1.1 A/D Converter Register 1 (AD1) (Default Value: 0000\_00??)

##### Bit 7: ADC Start Bit

1: Start (Only one time)

0: No change.

When A/D Conversion Complete Status Bit is high, write 1 to this bit to start A/D convert. And ADC Start Bit keeps low until hardware receives this request and can receive next request. And ADC Start Bit changes from low to high at the time.

##### Bit 6~4: Analog Input Pin Select

000: GP60, 001: GP61, 010: GP62, 011: GP63,

100: GP64, 101: GP65, 110: GP66, 111: GP67.

##### Bit 3: A/D Conversion Complete Status Bit (Read Only)

0: Conversion in progress.

1: Conversion completed.

##### Bit 2: Reserved

##### Bit 1~0: A/D Converter Result [1:0]

A/D converter result bit1 is LSB.

When A/D Conversion Complete Status Bit is high, A/D Converter Result is valid.



### 6.12.1.2 A/D Converter Register 2 (AD2) (Default Value: ???\_???)

#### Bit 7~0: A/D Converter Result [9:2]

A/D Converter Result bit 9 is MSB.

When A/D Conversion Complete Status Bit is high, A/D Converter Result is valid.

### 6.12.1.3 Pad Mode Register (PADMODE) (Default Value: 0000\_0000)

#### Bit 7~0: Pad mode select

0: Normal Mode

1: AD Mode

## 6.13 D/A Converter Block

The keyboard controller has two internal D-A converters (DA2 and DA1) with 8-bit resolution. The result of D-A conversion is output to the DA2 or DA1 pin.

Table 6-22.D/A Converter Register Define

| A/D CONVERT BLOCK(4) |      |                              |   |   |   |   |   |   |   |
|----------------------|------|------------------------------|---|---|---|---|---|---|---|
| EXTADDR              | NAME | 7                            | 6 | 5 | 4 | 3 | 2 | 1 | 0 |
| 52                   | DA1  | D/A 1 Convert Register [7:0] |   |   |   |   |   |   |   |
| 53                   | DA2  | D/A 2 Convert Register [7:0] |   |   |   |   |   |   |   |

Note:

Gray: Only with System Reset to initial.

### 6.13.1 Register Description

#### 6.13.1.1 D-A conversion register 1(DA1) (Default Value: 0000\_0000)

$$V_{GP57} = V_{REF} \times (N/256)$$

VREF is the reference voltage.

#### 6.13.1.2 D-A conversion register 2(DA2) (Default Value: 0000\_0000)

$$V_{GP56} = V_{REF} \times (N/256)$$

VREF is the reference voltage.



## 6.14 Fan Tachometer Block

Fan Tachometer Block provides two groups of Fan Tachometer, can be by GP40, GP41 inputs the wave form and calculates automatically that corresponding Count of cycle of rotational speed is counted. When real RPM is lower than setting value, interrupt request will occur.

Table 6-23.Fan Tachometer Register Define

| FAN BLOCK(2) |      |                  |   |   |   |   |   |   |   |
|--------------|------|------------------|---|---|---|---|---|---|---|
| EXTADDR      | NAME | 7                | 6 | 5 | 4 | 3 | 2 | 1 | 0 |
| 00           | FAN1 | Fan 1 Count[7:0] |   |   |   |   |   |   |   |
| 01           | FAN2 | Fan 2 Count[7:0] |   |   |   |   |   |   |   |

Note:

Gray: Only with System Reset to initial.

### 6.14.1 Register Description

#### 6.14.1.1 FAN 1/2 Count/Limit Register (FAN1/2) (Default Value: ???\_???)

##### Read:

Input clock=24MHz :

$$\text{Current Count. RPM} = (60 \times 1 \times 10e6) / (2 \times \text{Count} \times 256) = 117187.5/\text{Count}$$

Input clock=12MHz :

$$\text{Current Count. RPM} = (60 \times 1 \times 10e6) / (4 \times \text{Count} \times 256) = 58593/\text{Count}.$$

##### Write:

Set Count of tolerance of minimum RPM. When real RPM is lower than setting value, interrupt request will occur. The relation between RPM and Count is as follows:

Input clock=24MHz :

$$\text{RPM} = (60 \times 1 \times 10e6) / (2 \times \text{Count} \times 256) = 117187.5/\text{Count}.$$

$$\text{Count} = 117187.5/\text{RPM}.$$

Input clock=12MHz :

$$\text{RPM} = (60 \times 1 \times 10e6) / (4 \times \text{Count} \times 256) = 58593/\text{Count}.$$

$$\text{Count} = 58593/\text{RPM}.$$



## 6.15 Real Time Clock Generator Block

Base on 32.768KHz, Real Time Clock Generator Block finishes counts which include seconds, minutes, and hours automatically. It also provides alarm function.

When {RTCHR, RTCMIN, RTCSEC} and {RTCHRAL, RTCMINAL, RTCSECAL} are equal, interrupt will occur to Microprocessor automatically.

Table 6-24. Real Time Clock Generator Register Define

| REAL TIME CLOCK BLOCK(6) |          |                                 |   |   |   |   |   |   |   |
|--------------------------|----------|---------------------------------|---|---|---|---|---|---|---|
| EXTADDR                  | NAME     | 7                               | 6 | 5 | 4 | 3 | 2 | 1 | 0 |
| 70                       | RTCSEC   | RTC Seconds Register[7:0]       |   |   |   |   |   |   |   |
| 71                       | RTCSECAL | RTC Seconds Alarm Register[7:0] |   |   |   |   |   |   |   |
| 72                       | RTCMIN   | RTC Minutes Register[7:0]       |   |   |   |   |   |   |   |
| 73                       | RTCMINAL | RTC Minutes Alarm Register[7:0] |   |   |   |   |   |   |   |
| 74                       | RTCHR    | RTC Hours Register[7:0]         |   |   |   |   |   |   |   |
| 75                       | RTCHRAL  | RTC Hours Alarm Register[7:0]   |   |   |   |   |   |   |   |

Note:

Gray: Only with System Reset to initial.

*RTCSEC, RTCMIN, RTCHR should initial after local reset.*

### 6.15.1 Register Description

#### 6.15.1.1 RTC Second Register (RTCSEC) (Default Value: 0000\_0000)

Read: Indicate RTC second value at present.

Write: Set RTC second value at present.

#### 6.15.1.2 RTC Second Alarm Register (RTCSECAL) (Default Value: 0000\_0000)

Read: Indicate RTC second alarm at present.

Write: Set RTC second alarm value at present.

#### 6.15.1.3 RTC Minute Register (RTCMIN) (Default Value: 0000\_0000)

Read: Indicate RTC minute value at present.

Write: Set RTC minute value at present.



## **6.15.1.4 RTC Minute Alarm Register (RTCMINAL) (Default Value: 0000\_0000)**

Read: Indicate RTC minute alarm value at present.

Write: Set RTC minute alarm value at present.

## **6.15.1.5 RTC Hour Register (RTCHR) (Default Value: 0000\_0000)**

Read: Indicate RTC hour value at present.

Write: Set RTC hour value at present.

## **6.15.1.6 RTC Hour Alarm Register (RTCHRAL) (Default Value: 0000\_0000)**

Read: Indicate RTC hour alarm minute value at present.

Write: Set RTC hour alarm value at present.





## 6.16 External Interrupt Control Block

About External Interrupt, in W83L951DG/FG, External Interrupt Group1 (EXTINT1[7:0]), External Interrupt Group2 (EXTINT2[7:0]) and External Interrupt Group3 (EXTINT3[7:0]) interrupt source pins are same as GPA[7:0], GPB[7:0] and GPC[7:0].

Table 6-25. External Interrupt Control Register Define

| INTERRUPT BLOCK(17) |            |       |       |       |       |       |       |       |       |
|---------------------|------------|-------|-------|-------|-------|-------|-------|-------|-------|
| EXTADDR             | NAME       | 7     | 6     | 5     | 4     | 3     | 2     | 1     | 0     |
| 80                  | EXTINTE1   | INT17 | INT16 | INT15 | INT14 | INT13 | INT12 | INT11 | INT10 |
| 81                  | EXTINTE2   | INT27 | INT26 | INT25 | INT24 | INT23 | INT22 | INT21 | INT20 |
| 82                  | EXTINTE3   | INT37 | INT36 | INT35 | INT34 | INT33 | INT32 | INT31 | INT30 |
| 83                  | EXTINTREQ1 | INT17 | INT16 | INT15 | INT14 | INT13 | INT12 | INT11 | INT10 |
| 84                  | EXTINTREQ2 | INT27 | INT26 | INT25 | INT24 | INT23 | INT22 | INT21 | INT20 |
| 85                  | EXTINTREQ3 | INT37 | INT36 | INT35 | INT34 | INT33 | INT32 | INT31 | INT30 |
| 88                  | EXTINTT1   | INT17 | INT16 | INT15 | INT14 | INT13 | INT12 | INT11 | INT10 |
| 89                  | EXTINTT2   | INT27 | INT26 | INT25 | INT24 | INT23 | INT22 | INT21 | INT20 |
| 8A                  | EXTINTT3   | INT33 |       | INT32 |       | INT31 |       | INT30 |       |
| 8B                  | EXTINTT4   | INT37 |       | INT36 |       | INT35 |       | INT34 |       |

Note: All register initial after system reset.

### 6.16.1 Register Description

#### 6.16.1.1 External Interrupt Enable 1/2/3 Register (EXTINTE1/2/3) (Default Value: 0000\_0000)

1: Enable.

In enable state, external interrupt source will cause external interrupt request to generate the interrupt to Microprocessor.

0: Disable.

#### 6.16.1.2 External Interrupt Request 1/2/3 Register (EXTINTREQ1/2/3) (Default Value: 0000\_0000)

##### Bit7~0: External Interrupt Request

Read: 1: Requested, 0: No Requested.

Write: 1: Clear Request, 0: No Change



### **6.16.1.3 External Interrupt Trigger Select 1 Register (EXTINTT1) (Default Value: 0000\_0000)**

#### **Bit 7~0:INT17~10 Trigger Type**

Indicate the trigger type of External Interrupt 17~10.

1: Rising Edge

0: Falling Edge.

### **6.16.1.4 External Interrupt Trigger Select 2 Register (EXTINTT2) (Default Value: 0000\_0000)**

#### **Bit 7~0:INT27~20 Trigger Type**

Indicate the trigger type of External Interrupt 27~20.

1: Rising Edge

0: Falling Edge.

### **6.16.1.5 External Interrupt Trigger Select 3 Register (EXTINTT3) (Default Value: 0000\_0000)**

#### **Bit 7~6:INT33 Trigger Type**

Indicate the trigger type of External Interrupt 33.

1x: Rising Edge& Falling Edge,

01: Rising Edge,

00: Falling Edge

#### **Bit 5~4:INT32 Trigger Type**

Indicate the trigger type of External Interrupt 32.

1x: Rising Edge& Falling Edge,

01: Rising Edge,

00: Falling Edge

#### **Bit 3~2:INT31 Trigger Type**

Indicate the trigger type of External Interrupt 31.

1x: Rising Edge& Falling Edge,

01: Rising Edge,

00: Falling Edge

#### **Bit 1~0:INT30 Trigger Type**

Indicate the trigger type of External Interrupt 30.

1x: Rising Edge& Falling Edge,

01: Rising Edge

00: Falling Edge



## **6.16.1.6 External Interrupt Trigger Select 4 Register (EXTINTT4) (Default Value: 0000\_0000)**

### **Bit 7~6:INT37 Trigger Type**

Indicate the trigger type of External Interrupt 37.

1x: Rising Edge& Falling Edge,

01: Rising Edge

00: Falling Edge

### **Bit 5~4:INT36 Trigger Type**

Indicate the trigger type of External Interrupt 36.

1x: Rising Edge& Falling Edge,

01: Rising Edge

00: Falling Edge

### **Bit 3~2:INT35 Trigger Type**

Indicate the trigger type of External Interrupt 35.

1x: Rising Edge& Falling Edge,

01: Rising Edge

00: Falling Edge

### **Bit 1~0:INT34 Trigger Type**

Indicate the trigger type of External Interrupt 34.

1x: Rising Edge& Falling Edge,

01: Rising Edge

00: Falling Edge



## 6.17 Flash Memory

The W83L951DG/FG has a 64KByte, 3.3-volt only CMOS flash memory. The byte-wide ( $\times 8$ ) data appears on DQ7–DQ0. The device can be programmed and erased in-system with a standard 3.3V power supply. A 12-volt  $V_{PP}$  is not required. The unique cell architecture of the Flash results in fast program/erase operations with extremely low current consumption (compared to other comparable 3.3-volt flash memory products). The device can also be programmed and erased by using standard EPROM programmers.

### 6.17.1 External Programming Mode

The context of flash in Winbond Keyboard controller is empty by default. At the first use, you must program the flash by external writer device. For programming the flash by external device, the Winbond Keyboard controller must enter the flash-programming mode by TEST# Pin is connected to GND. RESET# Pin is connected to GND. FA [7:0] and FD [7:0] port is combined to GP07 to GP00. FA [7:0] is latched by the ALE (GP34).

In External Programming Mode, W83L951DG/FG protects Internal Flash data, so W83L951DG/FG will close “Read Command”. Under this condition, users must run “Erase Command” to use “Read Command”.

### 6.17.2 Internal Programming Mode

In W83L951DG/FG, in addition to access internal flash by outside, it provides to access SFR by Microprocessor. When Enable Memory Bit of Memory Mapping Control Register is high, and PC is F800~FFFFh, Microprocessor can access Internal Flash by SFR.

Table 6-26. Internal Programming Flash Register Define

| INTERNAL PROGRAMMING FLASH |       |         |     |     |          |   |   |   |            |
|----------------------------|-------|---------|-----|-----|----------|---|---|---|------------|
| INTADDR                    | NAME  | 7       | 6   | 5   | 4        | 3 | 2 | 1 | 0          |
| F9                         | FCON  | CEB     | OEB | WEB | Reserved |   |   |   | EXCHANG_GP |
| FA                         | FADDH | A[15:8] |     |     |          |   |   |   |            |
| FB                         | FADDL | A[7:0]  |     |     |          |   |   |   |            |
| FC                         | FDATA | DQ[7:0] |     |     |          |   |   |   |            |

#### 6.17.2.1 Flash Control Register (FCON) (Default Value: 0000\_0000)

##### 6.17.2.2 Bit7: Flash Chip Select Enable (CEB)

Like CE# Pin. Refer to next section for further details.

##### Bit6: Flash Output Enable (OEB)

Like OE# Pin. Refer to next section for further details.

##### Bit5: Flash Write Enable (WEB)

Like WE# Pin. Refer to next section for further details.

##### Bit4~Bit1: Reserved

##### Bit0: Exchange GPIOA/B/C to GPIO1/0/3 Function (Reserved)



### 6.17.2.3 Flash Address High Byte Register (FADDH) (Default Value: 0000\_0000)

Address [15:8] Input, Like A [15:8] Pin. Refer to next section for further details.

### 6.17.2.4 Flash Address Low Byte Register (FADDL) (Default Value: 0000\_0000)

Address [7:0] Input, Like A [7:0] Pin. Refer to next section for further details.

### 6.17.2.5 Flash Data Register (FDATA) (Default Value: 0000\_0000)

Write: Data Input

Read: Data Output

Like DQ [7:0] Pin. Refer to next section for further details.

## 6.17.3 Device Bus Operation

### 6.17.3.1 Read Mode

The read operation of the Internal Flash is controlled by #CE and #OE, both of which have to be low for the host to obtain data from the outputs. #CE is used for device selection. When #CE is high, the chip is de-selected and only standby power will be consumed. #OE is the output control and is used to gate data from the output pins. The data bus is in high impedance state when either #CE or #OE is high. Refer to the timing waveforms for further details.

### 6.17.3.2 Write Mode

Device erasure and programming are accomplished via the command register. The contents of the register serve as inputs to the internal state machine. The state machine outputs dictate the function of the device. The command register itself does not occupy any addressable memory location. The register is a latch used to store the commands, along with the address and data information needed to execute the command. The command register is written by bringing #WE to logic low state, while #CE is at logic low state and #OE is at logic high state. Addresses are latched on the falling edge of #WE or #CE, whichever happens later; while data is latched on the rising edge of #WE or #CE, whichever happens first. Standard microprocessor write timings are used.

Refer to AC Write Characteristics and the Erase/Programming Waveforms for specific timing parameters.

### 6.17.3.3 Output Disable Mode

With the #OE input at a logic high level ( $V_{IH}$ ), output from the device is disabled. This will cause the output pins to be in a high impedance state.

### 6.17.3.4 Write Pulse "Glitch" Protection

Noise pulses of less than 10 ns (typical) on #OE, #CE, or #WE will not initiate a write cycle.

## 6.17.4 Command Definitions

Device operations are selected by writing specific address and data sequences into the command register. Writing incorrect address and data values or writing them in the improper sequence will reset the device to the read mode. "Command Definitions" defines the valid register command sequences.



## 6.17.4.1 Read Command

The device will automatically power-up in the read state. In this case, a command sequence is not required to read data. Standard microprocessor read cycles will retrieve array data. This default value ensures that no spurious alteration of the memory content occurs during the power transition. The device will automatically return to read state after completing an Embedded Program or Embedded Erase algorithm.

Refer to the AC Read Characteristics and Waveforms for the specific timing parameters.

## 6.17.4.2 Byte Program Command

The device is programmed on a byte-by-byte basis. Programming is a four-bus-cycle operation. The program command sequence is initiated by writing two "unlock" write cycles, followed by the program set-up command. The program address and data are written next, which in turn initiate the embedded program algorithm. Addresses are latched on the falling edge of #CE or #WE, whichever happens later and the data is latched on the rising edge of #CE or #WE, whichever happens first. The rising edge of #CE or #WE (whichever happens first) begins programming using the Embedded Program Algorithm. Upon executing the algorithm, the system is not required to provide further controls or timings. The device will automatically provide adequate internally generated program pulses and verify the programmed cell margin.

The automatic programming operation is completed when the data on DQ7 (also used as Data Polling) is equivalent to the data written to this bit at which time the device returns to the read mode and addresses are no longer latched (see "Hardware Sequence Flags"). Therefore, the device requires that a valid address to the device be supplied by the system at this particular instance of time for Data Polling operations. Data Polling must be performed at the memory location which is being programmed.

Any commands written to the chip during the Embedded Program Algorithm will be ignored. If a hardware reset occurs during the programming operation, the data at that particular location will be corrupted.

Programming is allowed in any sequence and across sector boundaries. Beware that a data "0" cannot be programmed back to a "1". Attempting to program 0 back to 1, the toggle bit will stop toggling. Only erase operations can convert "0"s to "1"s.

Refer to the Programming Command Flow Chart using typical command strings and bus operations.

## 6.17.4.3 Chip Erase Command

Chip erase is a six-bus-cycle operation. There are two "unlock" write cycles, followed by writing the "set-up" command. Two more "unlock" write cycles are asserted, followed by the chip erase command.

Chip erase does not require the user to program the device prior to erase. Upon executing the Embedded Erase Algorithm command sequence the device will automatically erase and verify the entire memory for an all one data pattern. The erase is performed sequentially on each sectors at the same time (see "Feature"). The system is not required to provide any controls or timings during these operations.

The automatic erase begins on the rising edge of the last #WE pulse in the command sequence and terminates when the data on DQ7 is "1" at which time the device returns to read the mode.

Refer to the Erase Command Flow Chart using typical command strings and bus operations.



## 6.17.5 Write Operation Status

### 6.17.5.1 DQ7: Data Polling

The W39L040 device features Data Polling as a method to indicate to the host that the embedded algorithms are in progress or completed.

During the Embedded Program Algorithm, an attempt to read the device will produce the complement of the data last written to DQ7. Upon completion of the Embedded Program Algorithm, an attempt to read the device will produce the true data last written to DQ7.

During the Embedded Erase Algorithm, an attempt to read the device will produce a "0" at the DQ7 output.

Upon completion of the Embedded Erase Algorithm, an attempt to read the device will produce a "1" at the DQ7 output. For chip erase, the Data Polling is valid after the rising edge of the sixth pulse in the six #WE write pulse sequences. For sector erase, the Data Polling is valid after the last rising edge of the sector erase #WE pulse. Data Polling must be performed at sector addresses within any of the sectors being erased. Otherwise, the status may not be valid.

Just prior to the completion of Embedded Algorithm operations DQ7 may change asynchronously while the output enable (#OE) is asserted low. This means that the device is driving status information on DQ7 at one instant of time and then that byte's valid data at the next instant of time. Depending on when the system samples the DQ7 output, it may read the status or valid data. Even if the device has completed the Embedded Algorithm operations and DQ7 has a valid data, the data outputs on DQ0–DQ6 may be still invalid. The valid data on DQ0–DQ7 will be read on the successive read attempts.

The Data Polling feature is only active during the Embedded Programming Algorithm, Embedded Erase Algorithm, or sector erase time-out (see "Command Definitions").

### 6.17.5.2 DQ6: Toggle Bit

The Flash also features the "Toggle Bit" as a method to indicate to the host system that the embedded algorithms are in progress or completed.

During an Embedded Program or Erase Algorithm cycle, successive attempts to read (#OE toggling) data from the device at any address will result in DQ6 toggling between one and zero. Once the Embedded Program or Erase Algorithm cycle is completed, DQ6 will stop toggling and valid data will be read on the next successive attempt. During programming, the Toggle Bit is valid after the rising edge of the fourth #WE pulse in the four write pulse sequence. For chip erase, the Toggle Bit is valid after the rising edge of the sixth #WE pulse in the six write pulse sequence. For sector/page erase, the Toggle Bit is valid after the last rising edge of the sector/page erase #WE pulse. The Toggle Bit is active during the sector/page erase time-out.

Either #CE or #OE toggling will cause DQ6 to toggle.



## 6.17.6 Table of Operating Modes

Table 6-27. Device Bus Operations

| MODE           | #CE | #OE | #WE | A0 | A1 | DQ0~DQ7 |
|----------------|-----|-----|-----|----|----|---------|
| Read           | VIL | VIL | VIH | A0 | A1 | Dout    |
| Write          | VIL | VIH | VIL | A0 | A1 | Din     |
| Standby        | VIH | X   | X   | X  | X  | High Z  |
| Output Disable | VIL | VIH | VIH | X  | X  | High Z  |

Table 6-28. Command Define

| COMMAND DESCRIPTION | NO. OF CYCLE | 1 <sup>ST</sup> | 2 <sup>ND</sup> | 3 <sup>RD</sup> | 4 <sup>TH</sup> | 5 <sup>TH</sup> | 6 <sup>TH</sup> |
|---------------------|--------------|-----------------|-----------------|-----------------|-----------------|-----------------|-----------------|
|                     |              | ADDR, DATA      |                 |                 |                 |                 |                 |
| Read                | 1            | Ain, Dout       |                 |                 |                 |                 |                 |
| Byte Program        | 4            | 5555, AA        | 2AAA, 55        | 5555, A0        | Ain, Din        |                 |                 |
| Chip Erase          | 6            | 5555, AA        | 2AAA, 55        | 5555, 80        | 5555, AA        | 2AAA, 55        | 5555, 10        |
| Page Erase          | 6            | 5555 AA         | 2AAA 55         | 5555 80         | 5555 AA         | 2AAA 55         | PA 50           |
| Product ID Entry    | 3            | 5555 AA         | 2AAA 55         | 5555 90         |                 |                 |                 |
| Product ID Exit 1   | 3            | 5555 AA         | 2AAA 55         | 5555 F0         |                 |                 |                 |
| Product ID Exit 2   | 1            | XXXX F0         |                 |                 |                 |                 |                 |

**Notes:**

1. Address Format: A14 ~ A0(Hex); Data Format: DQ7 ~ DQ0(Hex)
2. Either one the two Product ID Exit commands can be used.
3. PA: Page Address = FXXXh to 0XXXh for page 15 to page 0.



6.17.7 Embedded Algorithm

6.17.7.1 Embedded Programming Algorithm

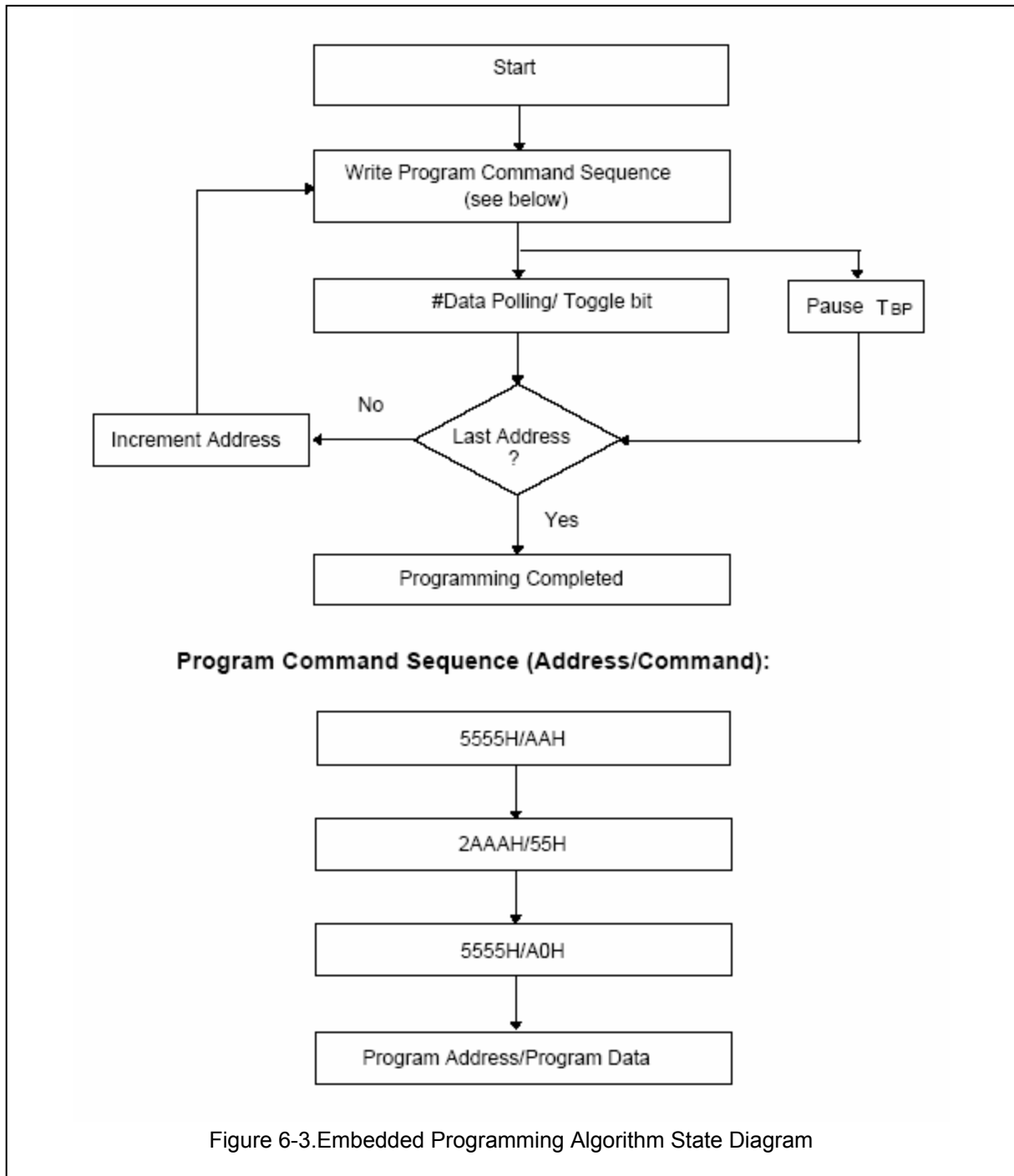

6.17.7.2 Embedded Erase Algorithm

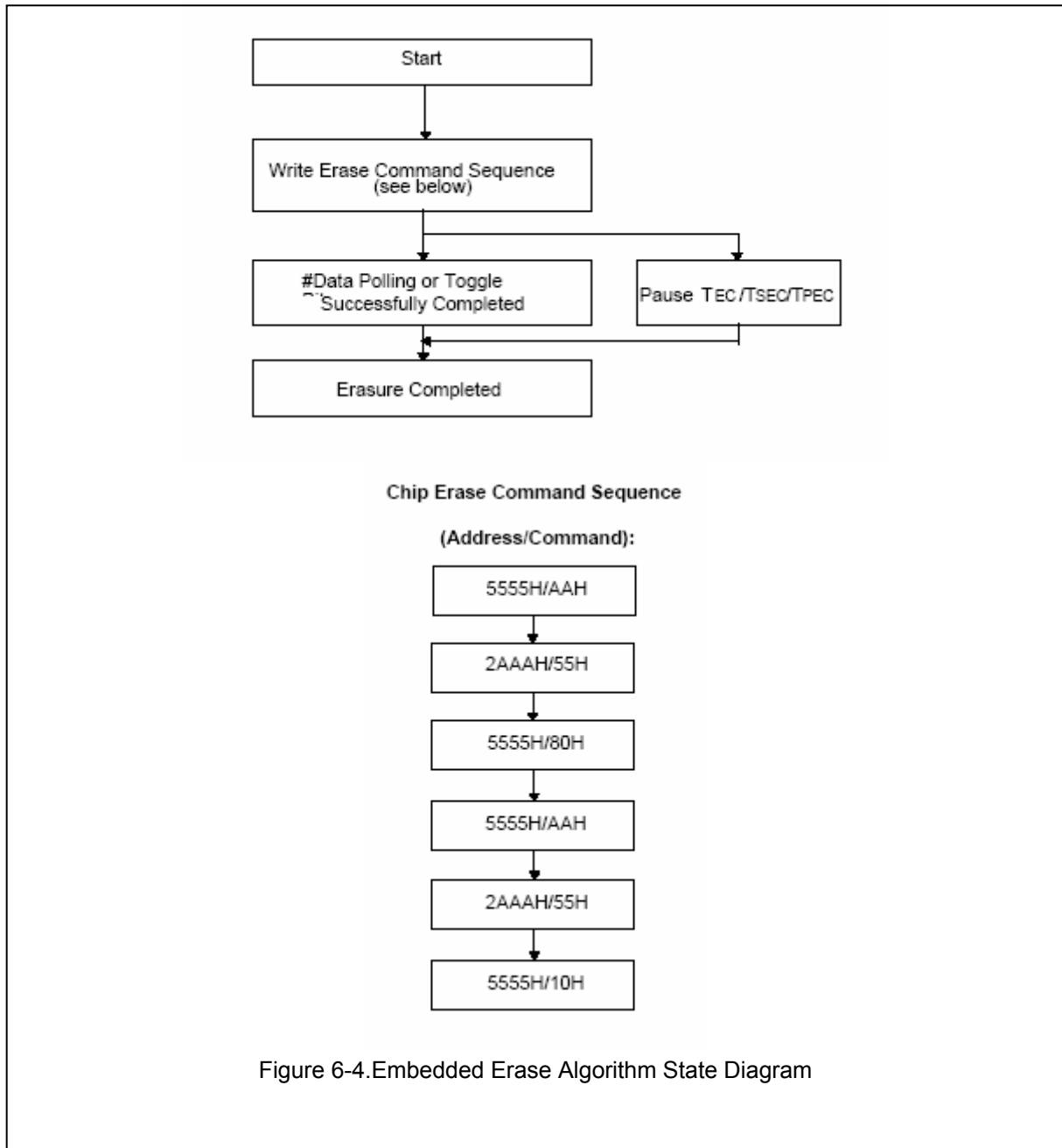
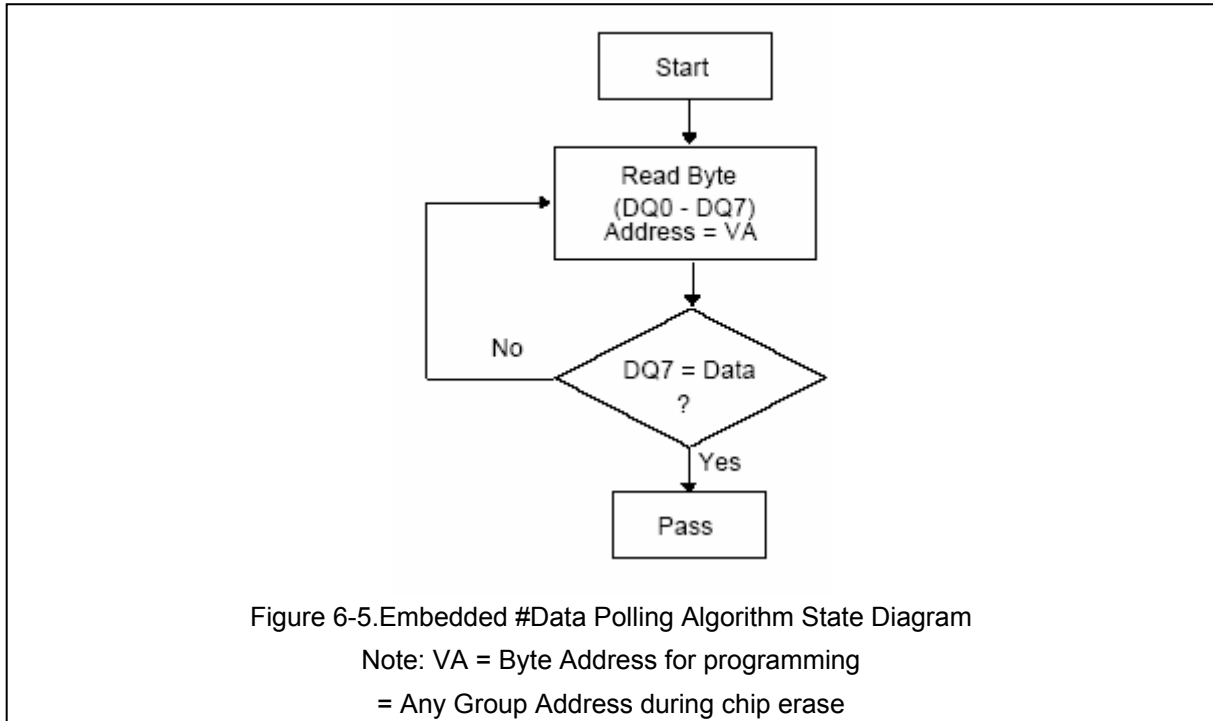
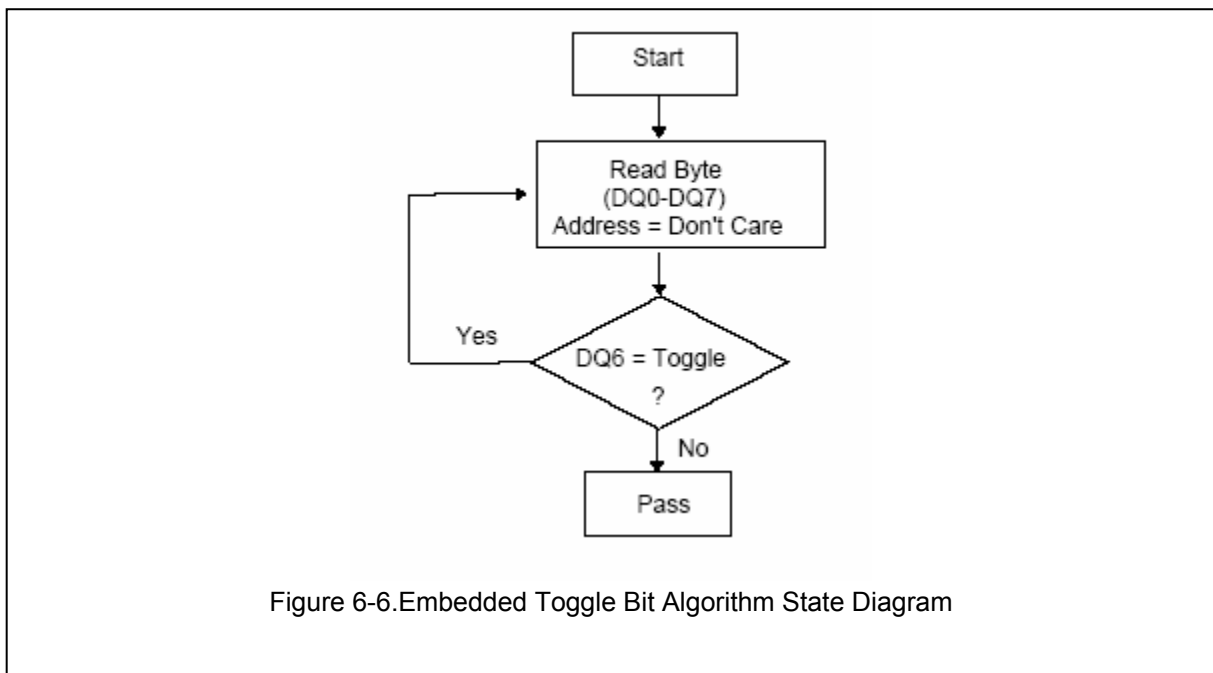

Figure 6-4.Embedded Erase Algorithm State Diagram

## 6.17.7.3 Embedded #Data Polling Algorithm



## 6.17.7.4 Embedded Toggle Bit Algorithm





### 6.17.8 Timing Parameters

Table 6-29. Read Cycle Timing Parameters Table

| PARAMETER                       | SYMBOL | MIN. | MAX. | UNIT |
|---------------------------------|--------|------|------|------|
| Read Cycle Time                 | TRC    | 90   | -    | ns   |
| Chip Enable Access Time         | TCE    | -    | 90   | ns   |
| Address Access Time             | TAA    | -    | 90   | ns   |
| Output Enable Access Time       | TOE    | -    | 45   | ns   |
| #CE Low to Active Output        | TCLZ   | 0    | -    | ns   |
| #OE Low to Active Output        | TOLZ   | 0    | -    | ns   |
| #CE High to High-Z Output       | TCHZ   | -    | 25   | ns   |
| #OE High to High-Z Output       | TOHZ   | -    | 25   | ns   |
| Output Hold from Address Change | TOH    | 0    | -    | ns   |

Note: (VDD = 3.3V ±0.3V, VSS = 0V, TA = 0 to 70° C or -40 to 85° C)

Table 6-30. Write Cycle Timing Parameters Table

| PARAMETER                    | SYMBOL | MIN. | TYP. | MAX. | UNIT |
|------------------------------|--------|------|------|------|------|
| Address Setup Time           | TAS    | 0    | -    | -    | nS   |
| Address Hold Time            | TAH    | 40   | -    | -    | nS   |
| #WE and #CE Setup Time       | TCS    | 0    | -    | -    | nS   |
| #WE and #CE Hold Time        | TCH    | 0    | -    | -    | nS   |
| #OE High Setup Time          | TOES   | 0    | -    | -    | nS   |
| #OE High Hold Time           | TOEH   | 0    | -    | -    | nS   |
| #CE Pulse Width              | TCP    | 100  | -    | -    | nS   |
| #WE Pulse Width              | TWP    | 100  | -    | -    | nS   |
| #WE High Width               | TWPH   | 100  | -    | -    | nS   |
| Data Setup Time              | TDS    | 40   | -    | -    | nS   |
| Data Hold Time               | TDH    | 10   | -    | -    | nS   |
| Byte Programming Time        | TBP    | -    | 35   | 50   | μS   |
| Chip Erase Cycle Time        | TEC    | -    | 50   | 100  | mS   |
| Sector/Page Erase Cycle Time | TEP    | -    | 12.5 | 25   | mS   |

Table 6-31. Power-up Timing Parameters Table

| PARAMETER                   | SYMBOL     | TYPICAL | UNIT    |
|-----------------------------|------------|---------|---------|
| Power-up to Read Operation  | TPU. READ  | 100     | $\mu$ S |
| Power-up to Write Operation | TPU. WRITE | 5       | mS      |

## 6.17.9 Timing Waveforms

The Timing Waveforms don't contain ALE(GP34 and TS(GP33). If using External Mode to access, TS pin must keep low. And use ALE(GP34) to do Low Address Byte(GP0) latch. ALE is high active and pulse width is at least 50ns. Low Address Byte(GP0) must be stable before ALE changes state from high to low.

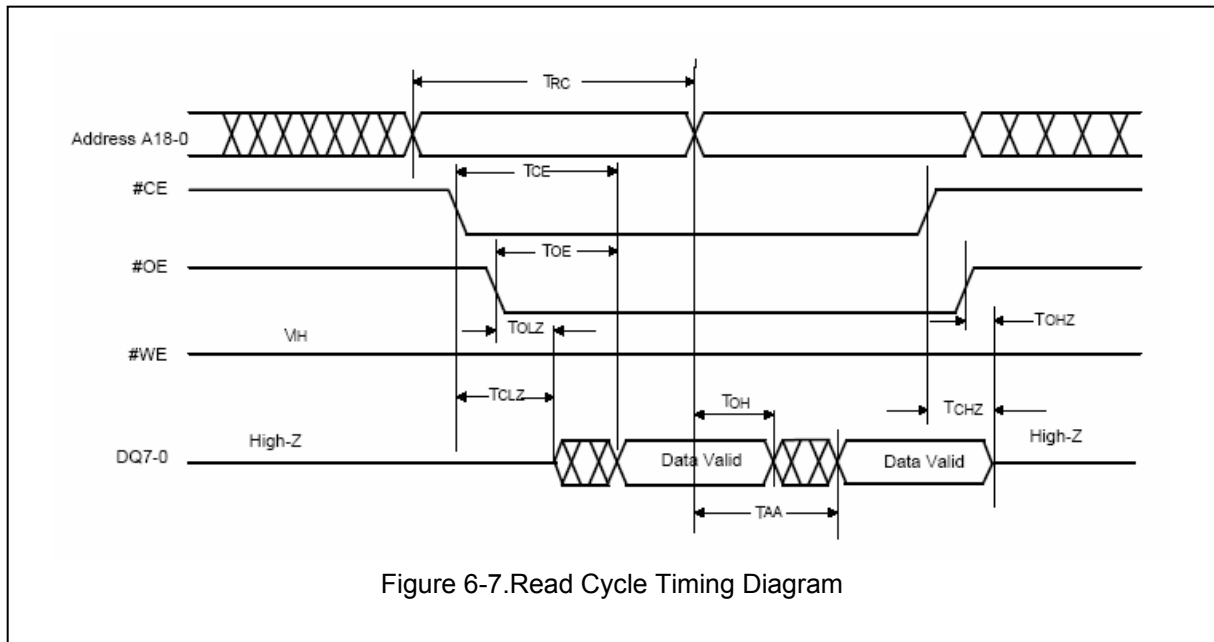

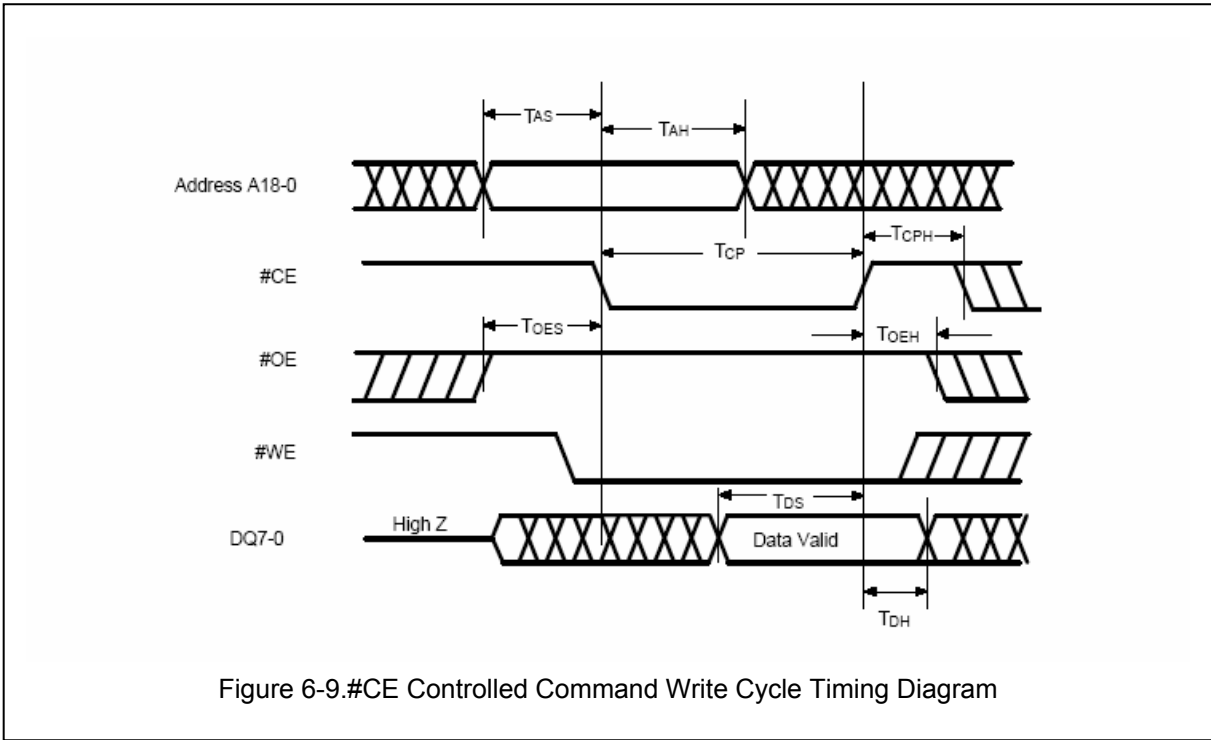
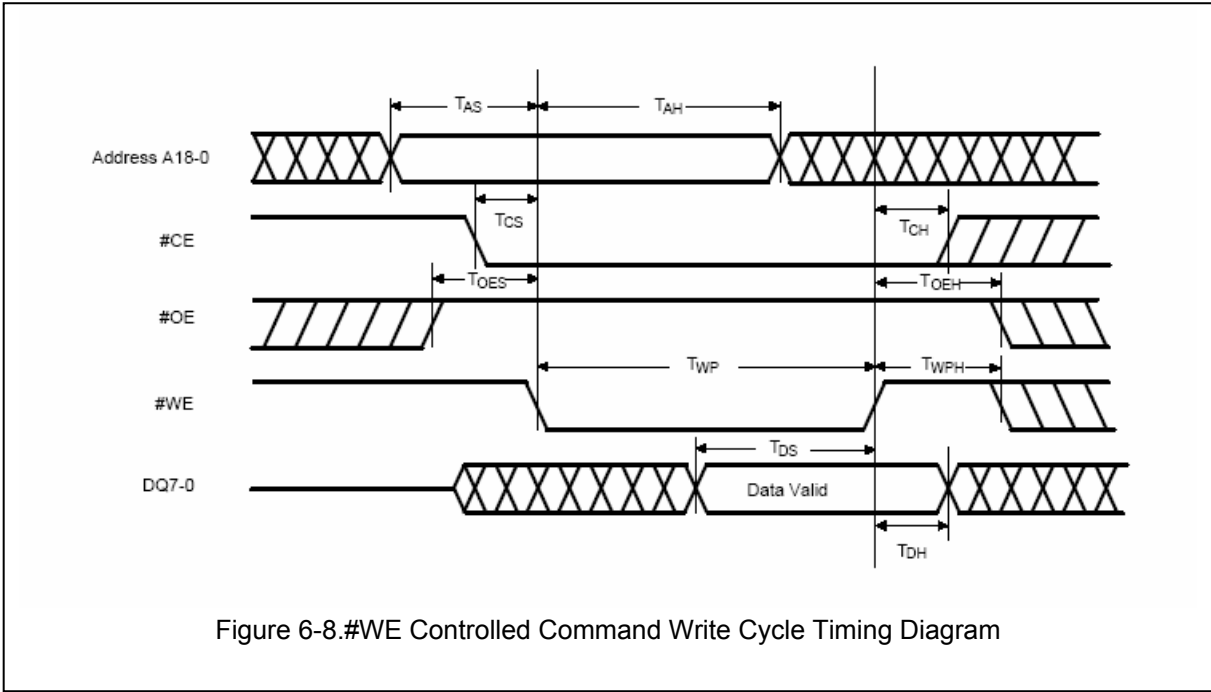

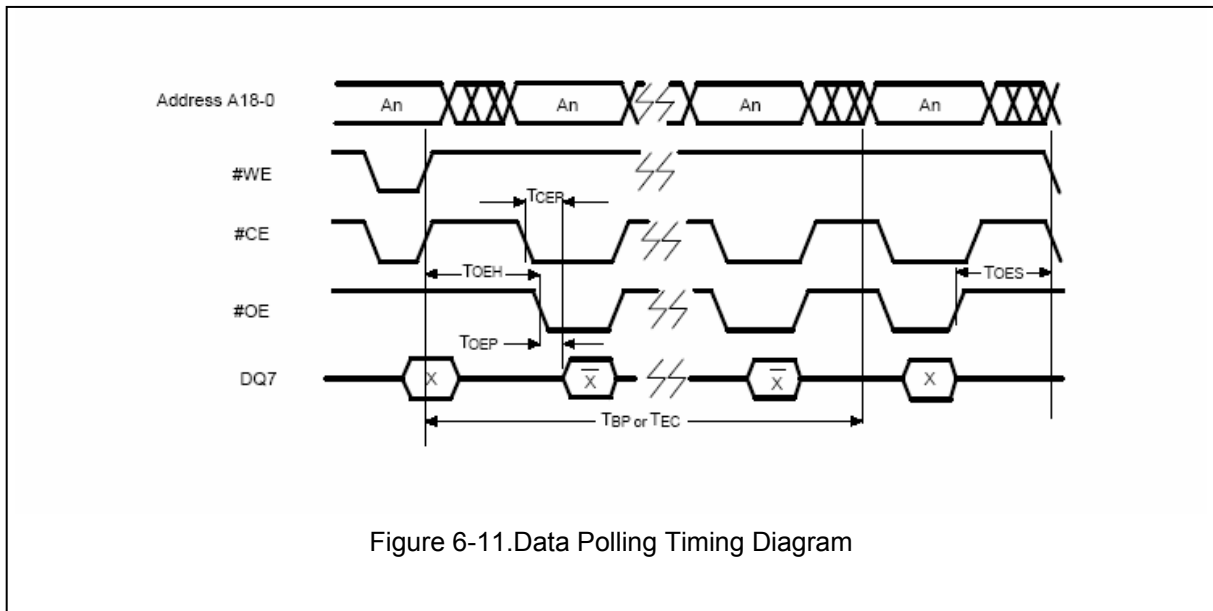
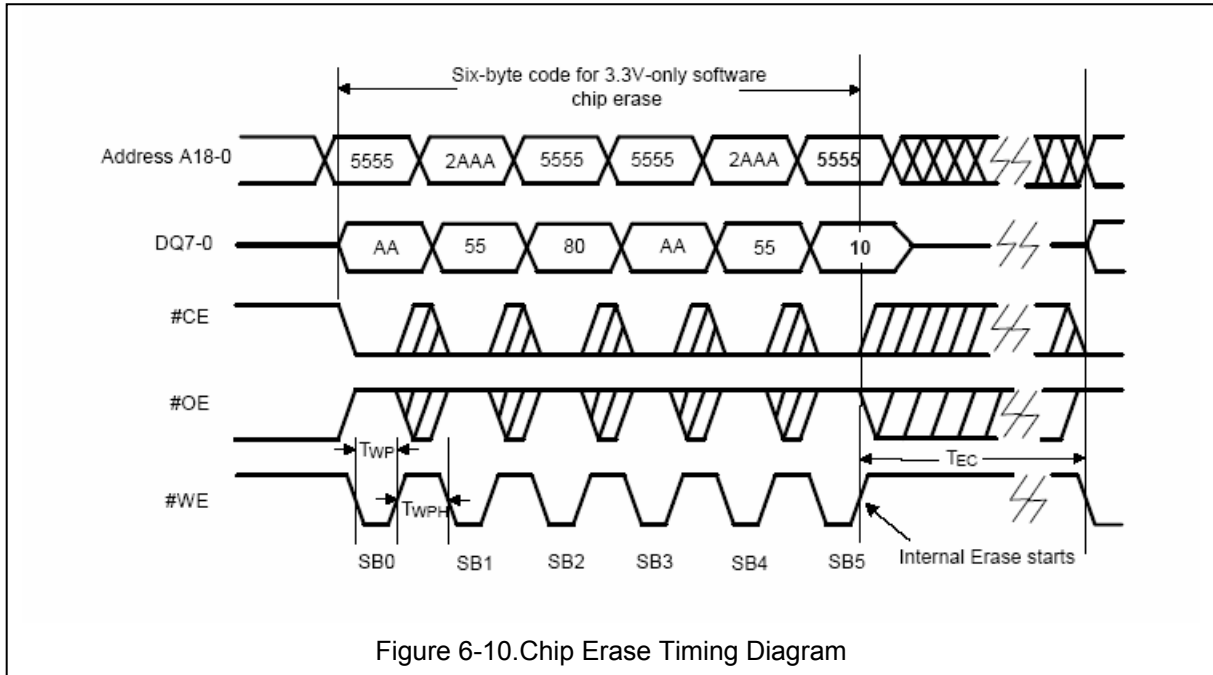

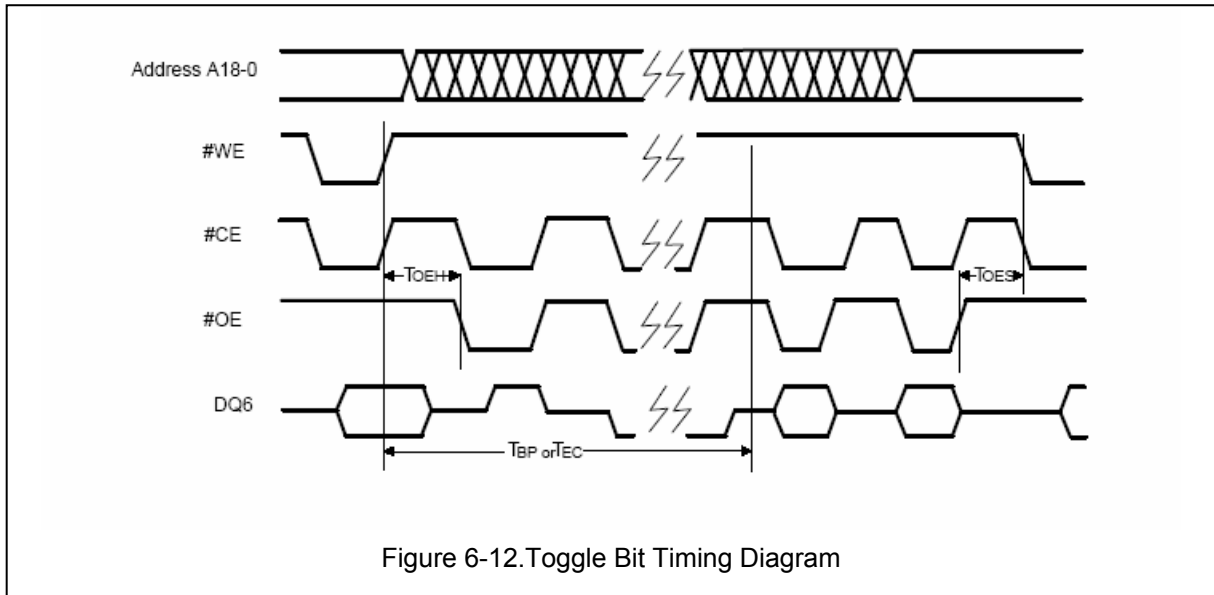

Figure 6-12. Toggle Bit Timing Diagram





## 7. SPECIFICATIONS

### 7.1 Absolute Maximum Ratings

Table 7-1 Absolute Maximum Rating Table

| PARAMETER             | RATING       | UNIT |
|-----------------------|--------------|------|
| Power Supply Voltage  | -0.5 to +4.6 | V    |
| Input Voltage         | 3.3 ± 10%    | V    |
| Operating Temperature | 0 to +70     | ° C  |
| Storage Temperature   | -55 to +125  | ° C  |

**Note:** Exposure to conditions beyond those listed under Absolute Maximum Ratings may adversely affect the life and reliability of the device.

### 7.2 Analog Characteristics

#### 7.2.1 ADC Characteristics

| PARAMETER                   | MIN | TYP | MAX  | UNIT |
|-----------------------------|-----|-----|------|------|
| Resolution                  |     | 10  |      | Bit  |
| Input Accuracy              |     |     | ±3   | LSB  |
| Input Voltage Range         |     |     | AVcc | V    |
| Voltage Conversion Duration |     |     | 1    | ms   |

#### 7.2.2 DAC Characteristics

| PARAMETER            | MIN | TYP | MAX  | UNIT |
|----------------------|-----|-----|------|------|
| Resolution           |     | 8   |      | Bit  |
| Offset Error         |     |     | ±2   | LSB  |
| Output Voltage Range |     |     | AVcc | V    |
| DAC Enable Delay     |     |     | 10   | μs   |

### 7.3 Power Supply Current Consumption

Table 7-2 Power Supply Current Consumption Table

| PARAMETER       | TYPICAL | UNIT | PIN CONDITIONS   |
|-----------------|---------|------|------------------|
| Normal Mode     | 30      | mA   | Output , No Load |
| Power Down Mode | 10      | uA   |                  |



## 7.4 DC Characteristics

(Ta = 0° C to 70° C, VDD = 3.3V ± 10%, VSS = 0V)

| I/O <sub>12tsm</sub> —Bi-directional pin, TTL level, Schmitt-trigger input, selectable 250uA/12mA sink capability, 12mA source capability |      |      |      |      |      |                       |
|---|------|------|------|------|------|-----------------------|
| PARAMETER   | SYM. | MIN. | TYP. | MAX. | UNIT | CONDITIONS            |
| Input Low Voltage   | VIL  |      |      | 0.8  | V    |                       |
| Input High Voltage  | VIH  | 2.0  |      |      | V    |                       |
| Input High Leakage  | ILIH |      |      | +1   | μA   | VIN = VDD             |
| Input Low Leakage   | ILIL |      |      | -1   | μA   | VIN = 0 V             |
| Output Low Voltage  | VOL  |      |      | 0.4  | V    | IOL = 12 mA           |
| Output High Voltage   | VOH  | 2.4  |      |      | V    | IOH = -12 mA / -250uA |

(Ta = 0° C to 70° C, VDD = 3.3V ± 10%, VSS = 0V)

| I/O <sub>12tsai</sub> — Bi-directional pin, TTL level, Schmitt-trigger input, Analog Input, 12mA source-sink capability |      |      |      |      |      |              |
|---|------|------|------|------|------|--------------|
| PARAMETER   | SYM. | MIN. | TYP. | MAX. | UNIT | CONDITIONS   |
| Input Low Voltage   | VIL  |      |      | 0.8  | V    |              |
| Input High Voltage  | VIH  | 2.0  |      |      | V    |              |
| Input High Leakage  | ILIH |      |      | +1   | μA   | VIN = VDD    |
| Input Low Leakage   | ILIL |      |      | -1   | μA   | VIN = 0 V    |
| Output Low Voltage  | VOL  |      |      | 0.4  | V    | IOL = 12 mA  |
| Output High Voltage   | VOH  | 2.4  |      |      | V    | IOH = -12 mA |

(Ta = 0° C to 70° C, VDD = 3.3V ± 10%, VSS = 0V)

| I/O <sub>12tsao</sub> — Bi-directional pin, TTL level, Schmitt-trigger input, Analog Output, 12mA source-sink capability |      |      |      |      |      |              |
|--|------|------|------|------|------|--------------|
| PARAMETER  | SYM. | MIN. | TYP. | MAX. | UNIT | CONDITIONS   |
| Input Low Voltage  | VIL  |      |      | 0.8  | V    |              |
| Input High Voltage   | VIH  | 2.0  |      |      | V    |              |
| Input High Leakage   | ILIH |      |      | +1   | μA   | VIN = VDD    |
| Input Low Leakage  | ILIL |      |      | -1   | μA   | VIN = 0 V    |
| Output Low Voltage   | VOL  |      |      | 0.4  | V    | IOL = 12 mA  |
| Output High Voltage  | VOH  | 2.4  |      |      | V    | IOH = -12 mA |

# W83L951DG/W83L951FG



(Ta = 0° C to 70° C, VDD = 3.3V ± 10%, VSS = 0V)

| I/O <sub>16tsh</sub> — Bi-directional pin, TTL level, Schmitt-trigger input, 5V Tolerant, 16mA source-sink capability |      |      |      |      |      |              |
|---|------|------|------|------|------|--------------|
| PARAMETER   | SYM. | MIN. | TYP. | MAX. | UNIT | CONDITIONS   |
| Input Low Voltage   | VIL  |      |      | 0.8  | V    |              |
| Input High Voltage  | VIH  | 2.0  |      |      | V    |              |
| Input High Leakage  | ILIH |      |      | +1   | μA   | VIN = VDD    |
| Input Low Leakage   | ILIL |      |      | -1   | μA   | VIN = 0 V    |
| Output Low Voltage  | VOL  |      |      | 0.4  | V    | IOL = 16 mA  |
| Output High Voltage   | VOH  | 2.4  |      |      | V    | IOH = -16 mA |

(Ta = 0° C to 70° C, VDD = 3.3V ± 10%, VSS = 0V)

| I/O <sub>24ts</sub> — Bi-directional pin, TTL level, Schmitt-trigger input, 16mA source-sink capability |      |      |      |      |      |              |
|---|------|------|------|------|------|--------------|
| PARAMETER   | SYM. | MIN. | TYP. | MAX. | UNIT | CONDITIONS   |
| Input Low Voltage   | VIL  |      |      | 0.8  | V    |              |
| Input High Voltage  | VIH  | 2.0  |      |      | V    |              |
| Input High Leakage  | ILIH |      |      | +1   | μA   | VIN = VDD    |
| Input Low Leakage   | ILIL |      |      | -1   | μA   | VIN = 0 V    |
| Output Low Voltage  | VOL  |      |      | 0.4  | V    | IOL = 24 mA  |
| Output High Voltage   | VOH  | 2.4  |      |      | V    | IOH = -24 mA |

(Ta = 0° C to 70° C, VDD = 3.3V ± 10%, VSS = 0V)

| I <sub>ts</sub> — Input pin, TTL level, Schmitt-trigger input |      |      |      |      |      |            |
|---|------|------|------|------|------|------------|
| PARAMETER   | SYM. | MIN. | TYP. | MAX. | UNIT | CONDITIONS |
| Input Low Voltage   | VIL  |      |      | 0.8  | V    |            |
| Input High Voltage  | VIH  | 2.0  |      |      | V    |            |
| Input High Leakage  | ILIH |      |      | +1   | μA   | VIN = VDD  |
| Input Low Leakage   | ILIL |      |      | -1   | μA   | VIN = 0 V  |

# W83L951DG/W83L951FG



## 8. ORDERING INSTRUCTION

| PART NUMBER | PACKAGE TYPE           | PRODUCTION FLOW          |
|-------------|------------------------|--------------------------|
| W83L951DG   | 128PIN LQFP (LEADFREE) | Commercial, 0°C to +70°C |
| W83L951FG   | 128PIN QFP (LEADFREE)  | Commercial, 0°C to +70°C |



## 9. HOW TO READ THE TOP MARKING

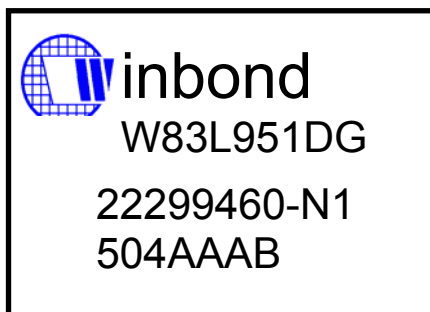

1st line: Winbond logo

2nd line: W83L951DG, chip part number for Leadfree product

3rd line: Manufacture tracking code 22299460-N1

4th line: Tracking code 504 A A AB

**504**: Packages made in '03, week 04

**A**: Assembly house ID; A means ASE, O means OSE, G means GR...

**A**: IC revision

**AB**: Internal version

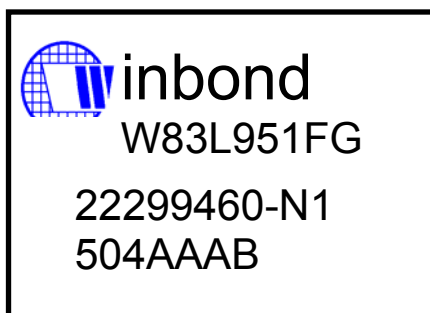

1st line: Winbond logo

2nd line: W83L951FG, chip part number for Leadfree product

3rd line: Manufacture tracking code 22299460-N1

4th line: Tracking code 504 A A AB

**504**: Packages made in '03, week 04

**A**: Assembly house ID; A means ASE, O means OSE, G means GR...

**A**: IC revision

**AB**: Internal version

# W83L951DG/W83L951FG



## 10. PACKAGE DIMENSIONS

Winbond provides two packages for customers that contain 128-pin LQFP and 128-pin QFP.

### 128-pin LQFP

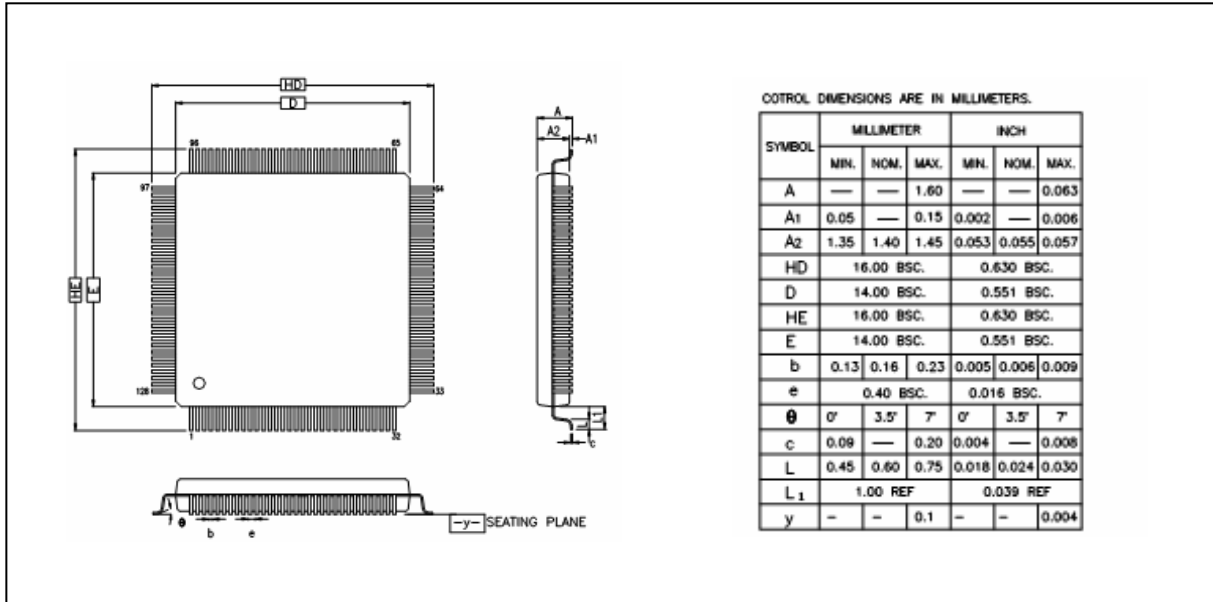

### 128pin- QFP

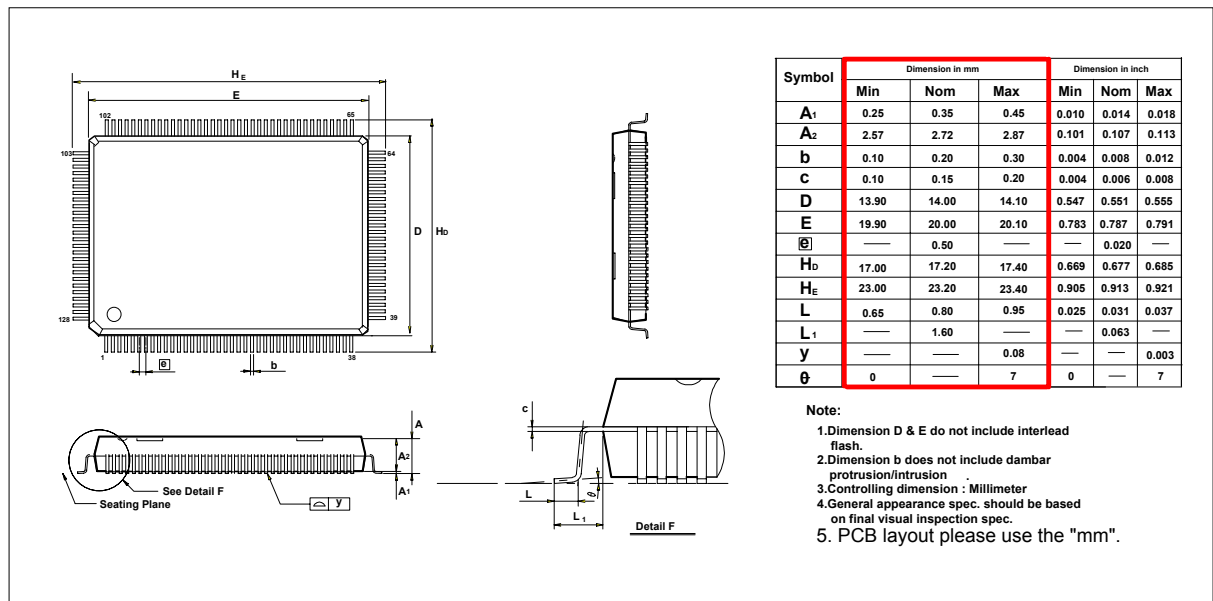

# W83L951DG/W83L951FG



## 11. DEMO CIRCUITS

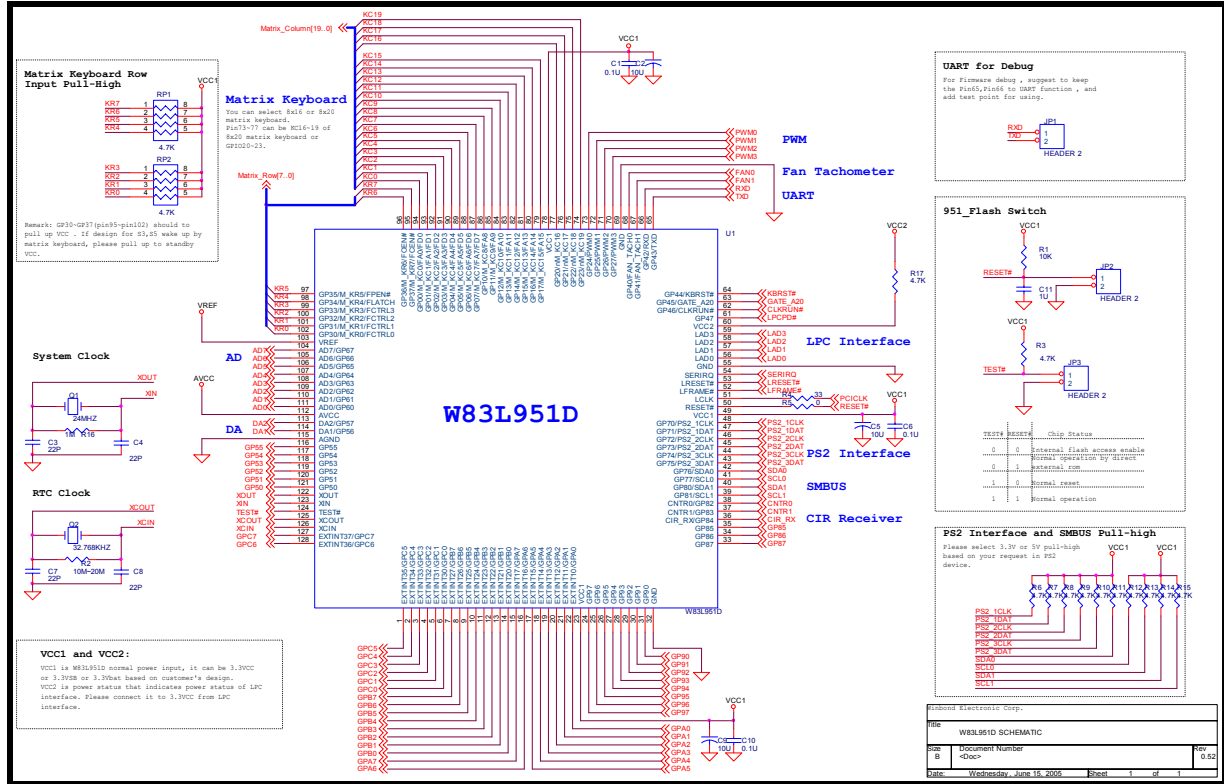



## Important Notice

Winbond products are not designed, intended, authorized or warranted for use as components in systems or equipment intended for surgical implantation, atomic energy control instruments, airplane or spaceship instruments, transportation instruments, traffic signal instruments, combustion control instruments, or for other applications intended to support or sustain life. Further more, Winbond products are not intended for applications wherein failure of Winbond products could result or lead to a situation wherein personal injury, death or severe property or environmental damage could occur.

Winbond customers using or selling these products for use in such applications do so at their own risk and agree to fully indemnify Winbond for any damages resulting from such improper use or sales.



### Headquarters

No. 4, Creation Rd. III,  
Science-Based Industrial Park,  
Hsinchu, Taiwan  
TEL: 886-3-5770066  
FAX: 886-3-5665577  
<http://www.winbond.com.tw/>

### Taipei Office

9F, No.480, Rueiguang Rd.,  
Neihu District, Taipei, 114,  
Taiwan, R.O.C.  
TEL: 886-2-8177-7168  
FAX: 886-2-8751-3579

### Winbond Electronics Corporation America

2727 North First Street, San Jose,  
CA 95134, U.S.A.  
TEL: 1-408-9436666  
FAX: 1-408-5441798

### Winbond Electronics Corporation Japan

7F Daini-ueno BLDG, 3-7-18  
Shinyokohama Kohoku-ku,  
Yokohama, 222-0033  
TEL: 81-45-4781881  
FAX: 81-45-4781800

### Winbond Electronics (Shanghai) Ltd.

27F, 2299 Yan An W. Rd. Shanghai,  
200336 China  
TEL: 86-21-62365999  
FAX: 86-21-62365998

### Winbond Electronics (H.K.) Ltd.

Unit 9-15, 22F, Millennium City,  
No. 378 Kwun Tong Rd.,  
Kowloon, Hong Kong  
TEL: 852-27513100  
FAX: 852-27552064

*Please note that all data and specifications are subject to change without notice.  
All the trademarks of products and companies mentioned in this datasheet belong to their respective owners.*