

**OBSOLETE PRODUCT**  
Contact factory for replacement model

# WPC03R

# 3 WATT REGULATED WIDE INPUT RANGE DC/DC CONVERTER

ISO9001  
CERTIFIED



## FEATURES

- Low Cost, High Performance
- Small DIP Package
- Full Power to +85°C
- Extended Temperature Range: -40°C to +85°C
- Industry Standard Pinouts
- Full Short Circuit Protection
- High Capacitive Loading Capability
- Protected Against High Input Voltage

## DESCRIPTION

The WPC03R is a family of high performance DC/DC converters that offers regulated outputs over input voltage ranges of 9-18V, 18-36V and 34-72V while offering a wide operating temperature range of -40°C to +85°C without derating.

Each WPC03R contains input filtering to minimize conducted noise. The design utilizes surface mounted components, including magnetics, to provide enhanced reliability.

The converter is designed to meet the requirements of EN60950 with the “L” pinout having 1,500 VDC isolation. All WPC03R converters are designed to withstand input voltage transients to 200% of nominal input voltage. An additional feature is the ability of the WPC03R to drive high capacitive loads.

## APPLICATIONS

- Telecommunications
- Battery Powered Systems
- Portable Instruments
- Transportation Equipment
- Distributed Power Systems

## SIMPLIFIED CIRCUIT SCHEMATIC

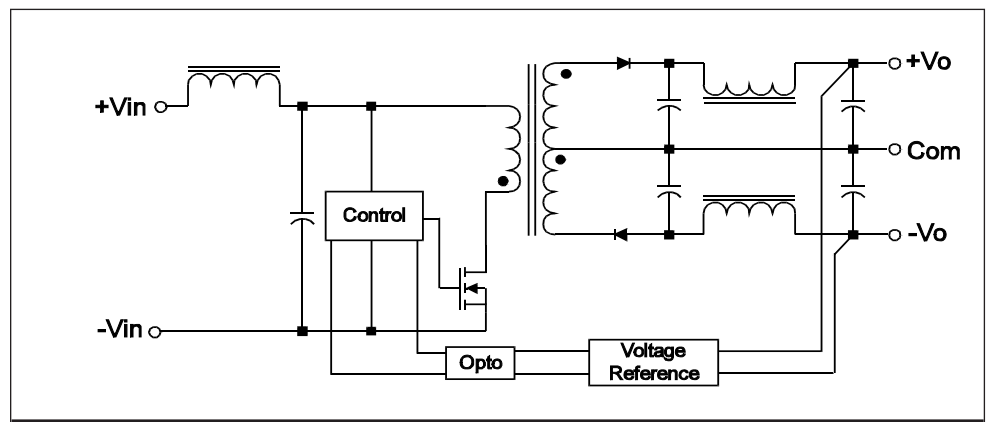

## ABSOLUTE MAXIMUM RATINGS

Output Short Circuit Protection-----Continuous
Internal Power Dissipation-----1.5W
Max Case Temperature-----+100°C

## ELECTRICAL SPECIFICATIONS

Specifications typical at  $T_A=25^\circ\text{C}$ , nominal input voltage, rated output current unless otherwise stated.

Model	Nominal Input Voltage (Volts)	Rated Output Voltage (Volts)	Output Current (mA)		Max Input Current (mA) Rated Load	Max Capacitive Load ( $\mu\text{F}$ )	Efficiency %
			Min Load (See Note 1)	Rated Load			
WPC03R12S05	12	5.0	60	600	448	600	77
WPC03R12S12	12	12.0	24	250	445	250	80
WPC03R12S15	12	15.0	20	200	445	200	81
WPC03R12D05	12	$\pm 5.0$	$\pm 30$	$\pm 300$	470	$\pm 300$	74
WPC03R12D12	12	$\pm 12.0$	$\pm 12$	$\pm 125$	475	$\pm 125$	76
WPC03R12D15	12	$\pm 15.0$	$\pm 10$	$\pm 100$	475	$\pm 100$	77
WPC03R24S05	24	5.0	60	600	230	600	74
WPC03R24S12	24	12.0	24	250	230	250	75
WPC03R24S15	24	15.0	20	200	225	200	76
WPC03R24D05	24	$\pm 5.0$	$\pm 30$	$\pm 300$	240	$\pm 300$	73
WPC03R24D12	24	$\pm 12.0$	$\pm 12$	$\pm 125$	235	$\pm 125$	74
WPC03R24D15	24	$\pm 15.0$	$\pm 10$	$\pm 100$	230	$\pm 100$	75
WPC03R48S05	48	5.0	60	600	120	600	74
WPC03R48S12	48	12.0	24	250	118	250	75
WPC03R48S15	48	15.0	20	200	116	200	76
WPC03R48D05	48	$\pm 5.0$	$\pm 30$	$\pm 300$	120	$\pm 300$	73
WPC03R48D12	48	$\pm 12.0$	$\pm 12$	$\pm 125$	118	$\pm 125$	76
WPC03R48D15	48	$\pm 15.0$	$\pm 10$	$\pm 100$	116	$\pm 100$	77

**NOTE 1:** Although minimum load specifications are indicated for load measurement purposes, all models will operate under no-load conditions.

## ORDERING INFORMATION

Device Family _____	WPC03R	xyzz	-
Indicates wide input power 3W regulated DC/DC			
Model Number _____			
Selected from Table of Electrical Characteristics			
xx=input voltage			
y=number of outputs: S=single, D=dual			
zz=output voltage			
Pinout option E or L _____			

## COMMON SPECIFICATIONS

Specifications typical at  $T_A=25^{\circ}\text{C}$ , nominal input voltage, rated output current unless otherwise stated.

Parameter	Conditions	Min	Typ	Max	Units
Input					
Voltage Range		9	12	18	Vdc
		18	24	36	Vdc
		34	48	72	Vdc
Reflected Ripple Current			50		mA p-p
Isolation					
Safety Standards	Designed to meet requirements of EN60950, EN41003 & UL1950				
Rated Voltage	"L" Pinout	1500			Vdc
	"E" Pinout	1000			Vdc
Test Voltage—60 Hz, 10 secs	"L" Pinout	1500			Vpk
	"E" Pinout	1000			Vpk
Resistance			10		GΩ
Capacitance			220		pF
Leakage Current	$V_{iso}=240\text{Vac}$ , 60 Hz		30		μArms
Output					
Rated Power				3	W
Voltage Setpoint Accuracy				+3.0	%
Temperature Coefficient			±0.02		%/°C
Line Regulation-singles	Low line to high line			±1.5%	%
Line Regulation-duals	Low line to high line			±1.5%	%
Load Regulation-singles	Min load to rated load			+2%	%
Load Regulation-duals	Min load to rated load			±2%	%
Ripple & Noise	BW=5 Hz to 20 MHz		50	100	mV p-p
General					
Switching Frequency	Variable Frequency Min - Max	70		225	kHz
MTTF per MIL-HDBK-217, Rev F	$T_A=25^{\circ}$		1,000,000		Hours
Weight			12		g
Temperature					
Operation		-40		+85	°C
Storage		-55		+125	°C

## THROUGH-HOLE SOLDERING INFORMATION

These devices are intended for wave soldering or manual soldering.

**They are not intended to be subject to surface mount processes under any circumstances.**

The normal wave soldering process can be used with these devices where the device is subjected to a maximum wave temperature of 260°C for a period of no more than 10 seconds. Within this time and temperature range, the integrity of the device's plastic body will not be compromised and internal temperatures within the converter will not exceed 175°C. Care should be taken to control manual soldering limits identical to that of wave soldering.

# MECHANICAL SPECIFICATIONS

## PINOUT “E”

Pin Number	Pin Function	
	Singles	Duals
1	+Vin	+Vin
2	No connection	-Vout
3	No connection	Common
10	-Vout	Common
11	+Vout	+Vout
12	-Vin	-Vin
13	-Vin	-Vin
14	+Vout	+Vout
15	-Vout	Common
22	No connection	Common
23	No connection	-Vout
24	+Vin	+Vin

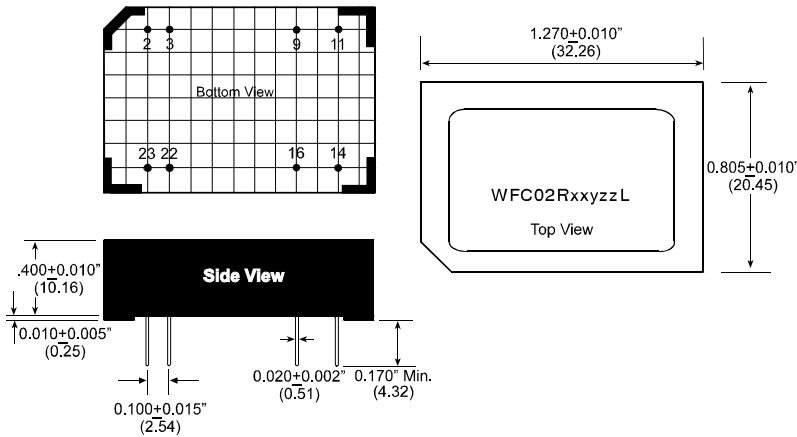
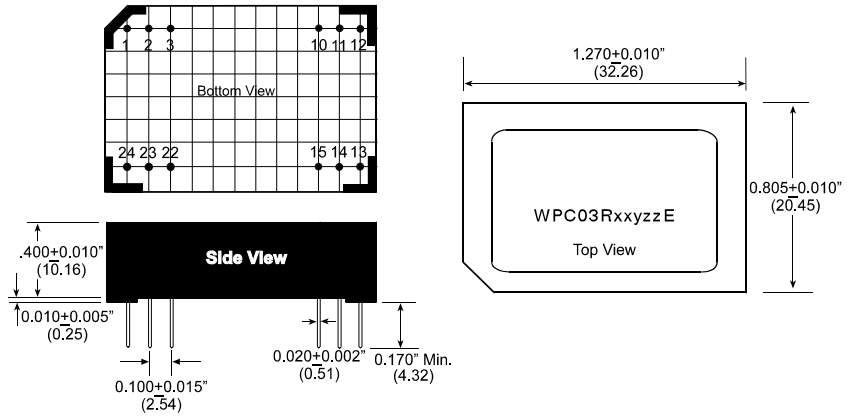

## PINOUT “L”

Pin Number	Pin Function	
	Singles	Duals
2	-Vin	-Vin
3	-Vin	-Vin
9	No connection	Common
11	No connection	-Vout
14	+Vout	+Vout
16	-Vout	Common
22	+Vin	+Vin
23	+Vin	+Vin

## TECHNICAL INFORMATION

### Notes:

- All dimensions in inches and (millimeters).
- Units are encapsulated in a low thermal resistance molding compound which has excellent chemical resistance, wide operating temperature range, and good electrical properties under high humidity environments. The encapsulant and outer shell of the unit have UL94V-0 ratings. Lead material is matte tin 100 microinches min., over nickel, 40-80 microinches.
- GRID: 0.100 inches, (2.54 mm).
- Pin Placement Tolerance:  $\pm 0.015''$ , ( $\pm 381$  mm).



Murata Power Solutions, Inc.

11 Cabot Boulevard, Mansfield, MA 02048-1151 U.S.A.

Tel: (508) 339-3000 (800) 233-2765 Fax: (508) 339-6356

www.murata-ps.com email: sales@murata-ps.com ISO 9001 & ISO 14001 REGISTERED

Murata Power Solutions, Inc. makes no representation that the use of its products in the circuits described herein, or the use of other technical information contained herein, will not infringe upon existing or future patent rights. The descriptions contained herein do not imply the granting of licenses to make, use, or sell equipment constructed in accordance therewith. Specifications are subject to change without notice. © 2009 Murata Power Solutions, Inc.

**USA:** Mansfield (MA), Tel: (508) 339 3000, email: sales@murata-ps.com

**Canada:** Toronto, Tel: (866) 740 1232, email: toronto@murata-ps.com

**UK:** Milton Keynes, Tel: +44 (0)1908 615232, email: mk@murata-ps.com

**France:** Montigny Le Bretonneux, Tel: +33 (0)1 34 60 01 01, email: france@murata-ps.com

**Germany:** München, Tel: +49 (0)89-544334-0, email: ped.munich@murata-ps.com

**Japan:** Tokyo, Tel: 3-3779-1031, email: sales\_tokyo@murata-ps.com

Osaka, Tel: 6-6354-2025, email: sales\_osaka@murata-ps.com

**China:** Shanghai, Tel: +86 215 027 3678, email: shanghai@murata-ps.com

Guangzhou, Tel: +86 208 221 8066, email: guangzhou@murata-ps.com

**Singapore:** Parkway Centre, Tel: +65 6348 9096, email: singapore@murata-ps.com