

## 1A Driver Transistor Built-In, Step-Up DC/DC Converters

## ■ GENERAL DESCRIPTION

The XC9128/XC9129 series are synchronous step-up DC/DC converters with a  $0.2\Omega$  (TYP.) N-channel driver transistor and a synchronous  $0.2\Omega$  (TYP.) P-channel switching transistor built-in. A highly efficient and stable current can be supplied up to 1.0A by reducing ON resistance of the built-in transistors. With a high switching frequency of 1.2MHz, a small inductor is selectable making the series ideally suited for applications requiring low profile or space saving solutions. With the MODE pin, the series provides mode selection of PWM control or PFM/PWM automatic switching control. In the PWM/PFM automatic switching mode, the series switches from PWM to PFM to reduce switching loss when load current is small. When load current is large, the series switches automatically to the PWM mode so that high efficiency is achievable over a wide range of load conditions. The series also provides small output ripple from light to large loads by using the built-in circuit which enables the smooth transition between PWM and PFM. With an adaptor enable function of the XC9128 series, when a voltage higher than the input voltage is applied to the output, the input and the output become isolated making it possible for the IC to work in parallel with the likes of an AC adaptor.

## ■ APPLICATIONS

- Digital audio equipment
- Digital cameras, Video equipment
- Computer Mice
- Various multi-function power supplies using alkali cells (1 to 3 cells), nickel hydride batteries, or single lithium cells

## ■ FEATURES

## High Efficiency, Large Current Step-Up Converter

<b>Output Current</b>	: 150mA @ $V_{OUT}=3.3V$ , $V_{IN}=0.9V$ 500mA @ $V_{OUT}=3.3V$ , $V_{IN}=1.8V$
<b>Input Voltage Range</b>	: 0.8V~6.0V
<b>Output Voltage Setting Range</b>	: 1.8V~5.3V (Externally set) Set up freely with a reference voltage supply of 0.45V ( $\pm 0.010V$ ) & external components
<b>Oscillation Frequency</b>	: 1.2MHz (Fixed oscillation frequency accuracy $\pm 15\%$ )
<b>Input Current</b>	: 1.0A
<b>Maximum Current Limit Control</b>	: 1.2A (MIN.), 2.0A (MAX.) : PWM, PWM/PFM control externally selectable
<b>High Speed</b>	: 100mV @ $V_{OUT}=3.3V$ , $V_{IN}=1.8V$ , $I_{OUT}=10mA \rightarrow 100mA$
<b>Transient Response</b>	: Thermal shutdown
<b>Protection Circuits</b>	: Integral latch method (Over current limit)
<b>Soft-Start Time</b>	: 5ms (TYP.) internally set
<b>Ceramic Capacitor Compatible</b>	
<b>Adaptor Enable Function (XC9128 series)</b>	
<b>Packages</b>	: MSOP-10, USP-10B, SOP-8
<b>Flag Output (XC9128 series)</b>	: Open-drain output

## ■ TYPICAL APPLICATION CIRCUIT

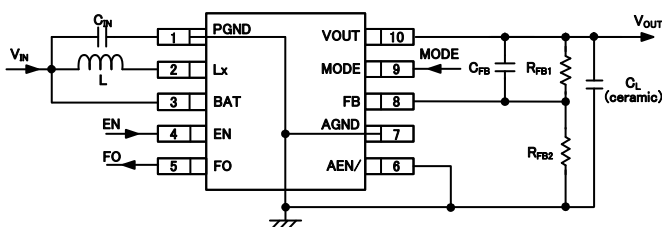

## ■ TYPICAL PERFORMANCE CHARACTERISTICS

- Efficiency vs. Output Current

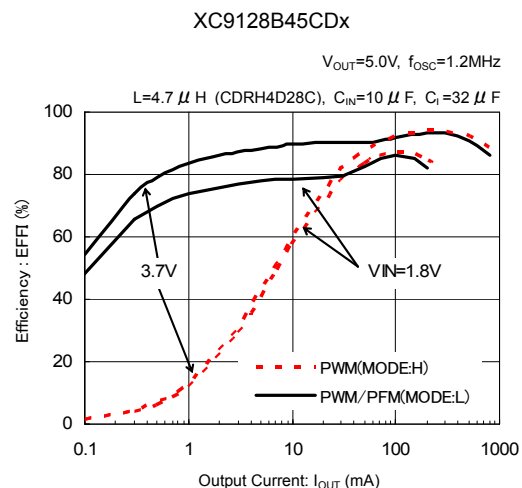

## PIN CONFIGURATION

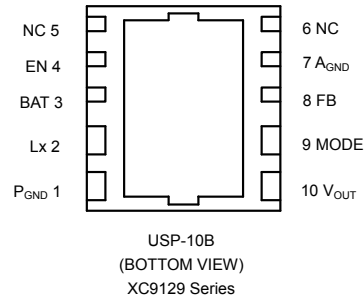
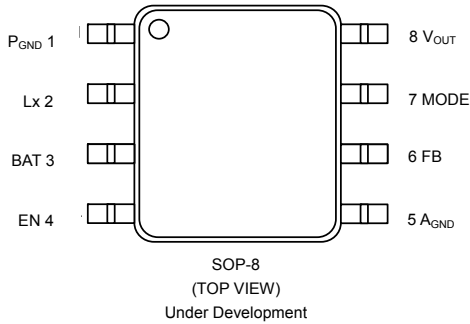
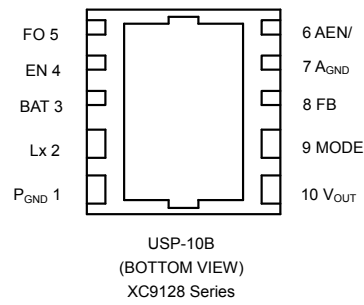
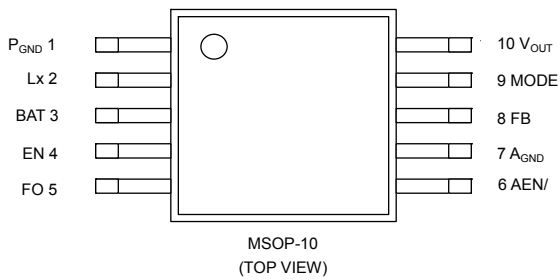

## PIN ASSIGNMENT

PIN NUMBER				PIN NAME	FUNCTION
MSOP-10*	USP-10B* (XC9128)	USP-10B* (XC9129)	SOP-8 **		
1	1	1	1	PGND	Power Ground
2	2	2	2	Lx	Output of Internal Power Switch
3	3	3	3	BAT	Battery Input
4	4	4	4	EN	Chip Enable
5	5	-	-	FO	Flag Output
6	6	-	-	AEN/	Adaptor Enable
7	7	7	5	AGND	Analog Ground
8	8	8	6	FB	Output Voltage Monitor
9	9	9	7	MODE	Mode Switch
10	10	10	8	VOUT	Output Voltage
-	-	5, 6	-	NC	No Connection

\* For MSOP-10 and USP-10B packages, please short the GND pins (pins 1 and 7).

\*The dissipation pad for the USP-10B package should be solder-plated following the recommended mount pattern and metal masking so as to enhance mounting strength and heat release. If the pad needs to be connected to other pins, it should be connected to the Ground pins (pins 1 and 7).

\*\* For SOP-8 package, please short the GND pins (pins 1 and 5).

## FUNCTION CHART

### 1. EN, AEN/ Pin Function

#### ●XC9128 Series

EN PIN	AEN/ PIN	FB PIN VOLTAGE	IC OPERATIONAL STATE	SOFT-START FUNCTION
L→H	L	-	Operation	Available
H	H→L	Lower than 0.45 × 0.8V	Operation	Available
H	H→L	Higher than 0.45 × 0.95V	Operation	Not Available
H	H	-	Step-Up Operation Shut-Down	-
L	L	-	Disable	-
L	H	-	Disable	-

\* Do not leave the EN and AEN/ Pins open.

#### ●XC9129 Series

EN PIN	IC OPERATIONAL STATE
H	Operation
L	Disable

\* Do not leave the EN Pin open.

### 2. MODE Pin Function

#### ●XC9128/XC9129 Series

MODE PIN	FUNCTION
H	PWM Control
L	PWM/PFM Automatic Switching Control

## PRODUCT CLASSIFICATION

#### ●Ordering Information

XC9128①②③④⑤⑥-⑦ \*<sup>1)</sup>.... MSOP-10, USP-10B

XC9129①②③④⑤⑥-⑦ \*<sup>1)</sup>.... USP-10B

SOP-8 (Under Development)

DESIGNATOR	DESCRIPTION	SYMBOL	DESCRIPTION
①	Transistor Built-In, Output Voltage Freely Set (FB voltage), Integral Protection Type	B	With integral protection
		D	Without integral protection
②③	Reference Voltage	45	Fixed reference voltage 0.45V
			②=4, ③=5
④	Oscillation Frequency	C	1.2MHz
⑤⑥-⑦	Packages Taping Type * <sup>2)</sup>	AR	MSOP-10
		AR-G	MSOP-10 (Halogen & Antimony free)
		DR	USP-10B
		DR-G	USP-10B (Halogen & Antimony free)
		SR	SOP-8 (under development)

<sup>(1)</sup> The "-G" suffix indicates that the products are Halogen and Antimony free as well as being fully RoHS compliant.

<sup>(2)</sup> The device orientation is fixed in its embossed tape pocket. For reverse orientation, please contact your local Torex sales office or representative. (Standard orientation: ⑤R-⑦, Reverse orientation: ⑤L-⑦)

## ■ BLOCK DIAGRAM

### ● XC9128 Series

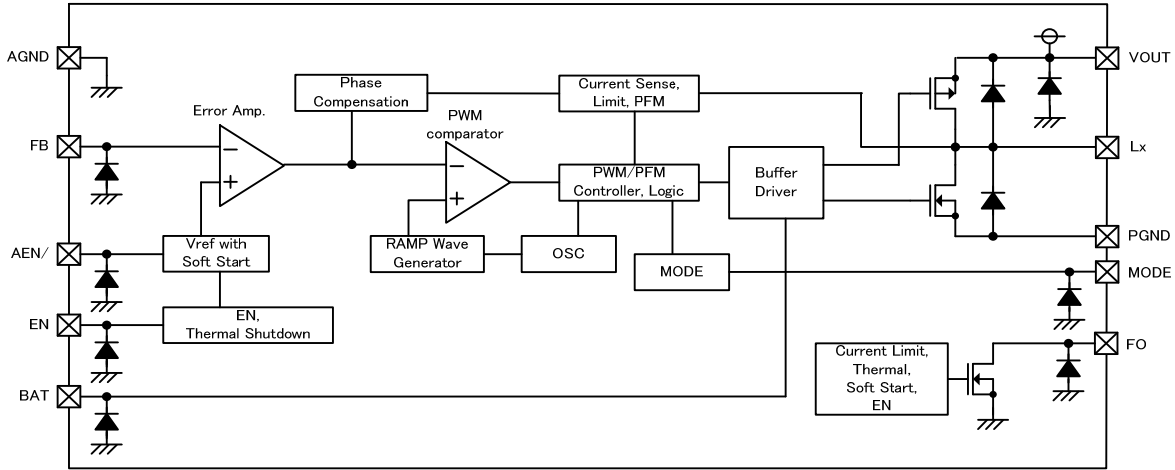

\* XC9129 Series

The XC9129 series does not have AEN/ pin and FO pin.

## ■ ABSOLUTE MAXIMUM RATINGS

Ta=25°C

PARAMETER	SYMBOL	RATINGS	UNITS
V <sub>OUT</sub> Pin Voltage	V <sub>OUT</sub>	- 0.3~6.5	V
AEN/ Pin Voltage <sup>(*)2</sup>	V <sub>AEN/</sub>	- 0.3~6.5	V
FO Pin Voltage <sup>(*)2</sup>	V <sub>FO</sub>	- 0.3~6.5	V
FO Pin Current <sup>(*)2</sup>	I <sub>FO</sub>	10	mA
FB Pin Voltage	V <sub>FB</sub>	- 0.3~6.5	V
BAT Pin Voltage	V <sub>BAT</sub>	- 0.3~6.5	V
MODE Pin Voltage	V <sub>MODE</sub>	- 0.3~6.5	V
EN Pin Voltage	V <sub>EN</sub>	- 0.3~6.5	V
L <sub>x</sub> Pin Voltage	V <sub>Lx</sub>	- 0.3~V <sub>OUT</sub> +0.3	V
L <sub>x</sub> Pin Current	I <sub>Lx</sub>	2000	mA
Power Dissipation	MSOP-10	P <sub>d</sub>	350 <sup>(*)1</sup>
	USP-10B		150
	SOP-8 (Under Development)		300
Operating Temperature Range	T <sub>opr</sub>	- 40~+85	°C
Storage Temperature Range	T <sub>stg</sub>	- 55~+125	°C

AGND, PGND is the standard voltage for all of voltages.

\*1: When implemented on a PCB.

\*2: The XC9129 series does not have AEN/ pin and FO pin. These pins are available only in the XC9128 series.

## ■ ELECTRICAL CHARACTERISTICS

XC9128/XC9129 Series

Topr=25 °C

PARAMETER	SYMBOL	CONDITIONS	MIN.	TYP.	MAX.	UNITS	CIRCUIT
Input Voltage	V <sub>IN</sub>	-	-	-	6.0	V	-
FB Voltage	V <sub>FB</sub>	V <sub>OUT</sub> =V <sub>IN</sub> =3.3V, V <sub>FO</sub> =0V <sup>(*)</sup> Voltage to start oscillation during V <sub>FB</sub> =0.46V → 0.44V	0.44	0.45	0.46	V	④
Output Voltage Setting Range	V <sub>OUTSET</sub>	-	1.8	-	5.3	V	①
Operation Start Voltage	V <sub>ST1</sub>	Connect to external components, R <sub>L</sub> =1kΩ	-	-	0.8	V	①
		Connect to external components, R <sub>L</sub> =33Ω	-	-	0.9 <sup>(*)</sup>	V	①
Oscillation Start Voltage	V <sub>ST2</sub>	Voltage to start oscillation during V <sub>IN</sub> =0V → 1V, R <sub>L</sub> =1kΩ	-	0.8	-	V	①
Operation Hold Voltage	V <sub>HLD</sub>	Connect to external components, R <sub>L</sub> =1kΩ	-	0.7	-	V	①
Supply Current 1	I <sub>DD1</sub>	V <sub>IN</sub> = V <sub>OUT</sub> = 3.3V, V <sub>FB</sub> =0.45×0.9	-	3	6	mA	②
Supply Current 2 (XC9128)	I <sub>DD2</sub>	V <sub>IN</sub> = V <sub>OUT</sub> = 3.3V	-	30	80	μA	②
Supply Current 2 (XC9129)		V <sub>FB</sub> =0.45×1.1 (Oscillation stop), V <sub>MODE</sub> =0V	-	28	78		
Input Pin Current	I <sub>BAT</sub>	V <sub>IN</sub> = 3.3V, V <sub>OUT</sub> = 1.8V, V <sub>EN</sub> =0V	-	2	10	μA	③
Stand-by Current	I <sub>STB</sub>	V <sub>IN</sub> = V <sub>OUT</sub> = 3.3V, V <sub>EN</sub> =0V	-	2	10	μA	②
Oscillation Frequency	f <sub>OSC</sub>	V <sub>IN</sub> = V <sub>OUT</sub> = 3.3V, V <sub>FO</sub> =0V <sup>(*)</sup> , V <sub>FB</sub> =0.45×0.9	1.02	1.20	1.38	MHz	④
Maximum Duty Cycle	D <sub>MAX</sub>	V <sub>IN</sub> = V <sub>OUT</sub> = 3.3V, V <sub>FO</sub> =0V <sup>(*)</sup> , V <sub>FB</sub> =0.45×0.9	85	92	96	%	④
Minimum Duty Cycle	D <sub>MIN</sub>	V <sub>IN</sub> = V <sub>OUT</sub> = 3.3V, V <sub>FO</sub> =0V <sup>(*)</sup> , V <sub>FB</sub> =0.45×1.1	-	-	0	%	④
PFM Switching Current	I <sub>PFM</sub>	Connect to external components, V <sub>MODE</sub> =0V, R <sub>L</sub> =330Ω	-	250	400	mA	①
Efficiency <sup>(*)</sup>	EFFI	Connect to external components, R <sub>L</sub> =33Ω	-	93	-	%	①
Lx SW "Pch" ON Resistance	R <sub>LxP</sub>	V <sub>IN</sub> =V <sub>Lx</sub> =V <sub>OUT</sub> +50mV, V <sub>FB</sub> =0.45 × 1.1 <sup>(*)</sup>	-	0.20	0.35 <sup>(*)</sup>	Ω	⑤
Lx SW "Nch" ON Resistance	R <sub>LxN</sub>	V <sub>IN</sub> =V <sub>OUT</sub> =3.3V, Lx =50mV <sup>(*)</sup>	-	0.20 <sup>(*)</sup>	0.35 <sup>(*)</sup>	Ω	⑦
Lx Leak Current	I <sub>LXL</sub>	V <sub>IN</sub> =V <sub>OUT</sub> = V <sub>Lx</sub> , V <sub>FB</sub> =0V	-	1	-	μA	⑤
Current Limit <sup>(*)</sup>	I <sub>LIM</sub>	V <sub>OUT</sub> >2.5V	1.2	1.5	2.0	A	①
Integral Latch Time (XC9128) <sup>(*)</sup>	t <sub>LAT</sub>	Time to stop oscillation during R <sub>L</sub> =33Ω → 3.3Ω, V <sub>FO</sub> =L → H	-	3.5	-	ms	①
Integral Latch Time (XC9129) <sup>(*)</sup>		Time to stop oscillation during R <sub>L</sub> =33Ω → 3.3Ω					
Soft-Start Time 1	t <sub>SS1</sub>	Time to start oscillation during V <sub>EN</sub> =0V → V <sub>IN</sub> at V <sub>IN</sub> = V <sub>OUT</sub> = 3.3V, V <sub>FO</sub> =0V, V <sub>FB</sub> =0.45×0.95	1.7	5.3	10.5	ms	④
Soft-Start Time 2 <sup>(*)</sup>	t <sub>SS2</sub>	V <sub>IN</sub> = V <sub>OUT</sub> = 3.3V, V <sub>FO</sub> =0V, V <sub>FB</sub> =0.45×0.95 Time to start oscillation during V <sub>AEN</sub> =V <sub>IN</sub> →0V.	-	0.02	0.04	ms	④
Soft-Start Time 3 <sup>(*)</sup>	t <sub>SS3</sub>	V <sub>IN</sub> = V <sub>OUT</sub> = 3.3V, V <sub>FO</sub> =0V, V <sub>FB</sub> =0.45×0.8 Time to start oscillation during V <sub>AEN</sub> =V <sub>IN</sub> →0V	1.7	5.3	10.5	ms	④
Thermal Shutdown Temperature	T <sub>TSD</sub>	-	-	150	-	°C	-
Hysteresis Width	T <sub>HYS</sub>	-	-	20	-	°C	-
Output Voltage Drop Protection <sup>(*)</sup>	V <sub>LVP</sub>	V <sub>IN</sub> = 3.3V Voltage to stop oscillation during V <sub>OUT</sub> =1.56V→1.3V	1.3	1.48	1.56	V	⑥
FO Output Current <sup>(*)</sup>	I <sub>FO_OUT</sub>	V <sub>IN</sub> = V <sub>OUT</sub> = 3.3V, V <sub>FO</sub> =0.25V	1.3	1.7	2.2	mA	④
FO Leakage Current <sup>(*)</sup>	I <sub>FO_Leak</sub>	V <sub>IN</sub> = V <sub>OUT</sub> = 3.3V, V <sub>EN</sub> =0V, V <sub>FO</sub> =1V	-	0	1	μA	④

## ELECTRICAL CHARACTERISTICS (Continued)

●XC9128/XC9129 Series (Continued)

Topr=25 °C

PARAMETER	SYMBOL	CONDITIONS	MIN.	TYP.	MAX.	UNITS	CIRCUIT
EN "H" Voltage	VENH	$V_{IN}=V_{OUT}=3.3V, V_{FO}=0V$ <sup>(*)8</sup> Voltage to start oscillation during $V_{FB}=0.45 \times 0.9, V_{EN}=0.2V \rightarrow 0.65V$	0.65	-	6.0	V	④
EN "L" Voltage	VENL	$V_{IN}=V_{OUT}=3.3V, V_{FO}=0V$ <sup>(*)8</sup> Voltage to stop oscillation during $V_{FB}=0.45 \times 0.9,$ $V_{EN}=0.65V \rightarrow 0.2V$	-	-	0.2	V	④
MODE "H" Voltage	VMODEH	$R_L=330\Omega$ , Voltage operates at PWM control	0.65	-	6.0	V	①
MODE "L" Voltage	VMODEL	$R_L=330\Omega$ , Voltage operates at PFM control	AGND	-	0.2	V	①
AEN/ Voltage <sup>(*)7</sup>	VAEN/	$V_{IN}=V_{OUT}=3.3V, V_{FO}=0V$ Voltage to start oscillation during $V_{AEN/}=0.9V \rightarrow 0.7V$	0.7	0.8	0.9	V	④
EN "H" Current	IENH	$V_{IN}=V_{OUT}=V_{FB}=V_{EN}=6.0V$	-	-	0.1	$\mu A$	②
EN "L" Current	IENL	$V_{IN}=V_{OUT}=V_{FB}=6.0V, V_{EN}=0V$	-0.1	-	-	$\mu A$	②
MODE "H" Current	IMODEH	$V_{IN}=V_{OUT}=V_{FB}=V_{MODE}=6.0V$	-	-	0.1	$\mu A$	②
MODE "L" Current	IMODEL	$V_{IN}=V_{OUT}=V_{FB}=6.0V, V_{MODE}=0V$	-0.1	-	-	$\mu A$	②
AEN/ "H" Current <sup>(*)7</sup>	IAEN/H	$V_{IN}=V_{OUT}=V_{FB}=V_{AEN/}=6.0V$	-	-	0.1	$\mu A$	②
AEN/ "L" Current <sup>(*)7</sup>	IAEN/L	$V_{IN}=V_{OUT}=6.0V, V_{EN}=0V, V_{AEN/}=0V$	-0.1	-	-	$\mu A$	②
FB "H" Current	IFBH	$V_{IN}=V_{OUT}=V_{FB}=6.0V$	-	-	0.1	$\mu A$	②
FB "L" Current	IFBL	$V_{IN}=V_{OUT}=6.0V, V_{FB}=0V$	-0.1	-	-	$\mu A$	②

Test Conditions:

For the Circuit No.1, unless otherwise stated,  $V_{IN}=1.8V, V_{EN}=V_{MODE}=V_{FO}=3.3V, V_{AEN/}=0V$  <sup>(\*)8</sup>  
 For the Circuit No.2, unless otherwise stated,  $V_{IN}=1.8V, V_{FB}=0V, V_{EN}=V_{MODE}=3.3V, V_{AEN/}=0V$  <sup>(\*)8</sup>  
 For the Circuit No.3, unless otherwise stated,  $V_{IN}=1.8V, V_{OUT}=V_{EN}=V_{MODE}=3.3V, V_{FB}=0V$   
 For the Circuit No.4, unless otherwise stated,  $V_{IN}=1.8V, V_{FB}=0V, V_{EN}=V_{MODE}=V_{pull}=V_{FO}=3.3V, V_{AEN/}=0V$  <sup>(\*)8</sup>  
 For the Circuit No.5, unless otherwise stated,  $V_{IN}=3.3V, V_{AEN/}=0V$  <sup>(\*)8</sup>  
 For the Circuit No.6, unless otherwise stated,  $V_{EN}=V_{MODE}=V_{pull}=V_{FO}=3.3V, V_{FB}=0V$  <sup>(\*)8</sup>  
 For the Circuit No.7, unless otherwise stated,  $V_{EN}=V_{MODE}=3.3V$

External Components:

For the Circuit No.1,  $R_{FB1}=270k\Omega, R_{FB2}=43k\Omega, C_{FB}=12pF, L=4.7\mu H$  (LTF5022 TDK),  $C_{L1}=22\mu F$  (ceramic),  $C_{L2}=10\mu F$  (ceramic),  $C_{IN}=10\mu F$  (ceramic)  
 For the Circuit No.2,3,  $C_{IN}=1\mu F$  (ceramic)  
 For the Circuit No.4,6,  $C_{IN}=1\mu F$  (ceramic),  $R_{pull}=300\Omega$   
 For the Circuit No.5,  $C_{IN}=1\mu F$  (ceramic),  $C_{OUT}=1\mu F$  (ceramic)  
 For the Circuit No.7,  $C_{IN}=1\mu F$  (ceramic),  $C_{OUT}=1\mu F$  (ceramic), SBD =XBS304S17 (TOREX),  $R_{pull}=0.5\Omega$

\*1 : Designed value

\*2 : Efficiency ={(output voltage) X (output current)} ÷ {(input voltage) X (input current)} X 100

\*3 :  $L_x$  SW "P-ch" ON resistance=( $V_{Lx}-V_{OUT}$  pin test voltage) ÷100mA

\*4 : Testing method of  $L_x$  SW "N-ch" ON resistance is stated at test circuits.

\*5 : Current flowing through the Nch driver transistor is limited.

\*6 : The XC9128D/XC9129D series does not have integral latch protection and  $V_{LVP}$  function.  
 This is only available with the XC9128B/XC9129B series.

\*7 : The XC9129 series does not have FO and AEN/ pins. These pins are only available in the XC9128 series.

\*8 : The XC9129 series does not have FO and AEN/ pins. The AEN/FO functions are only effective for the test of the XC9128 series.

## TYPICAL APPLICATION CIRCUIT

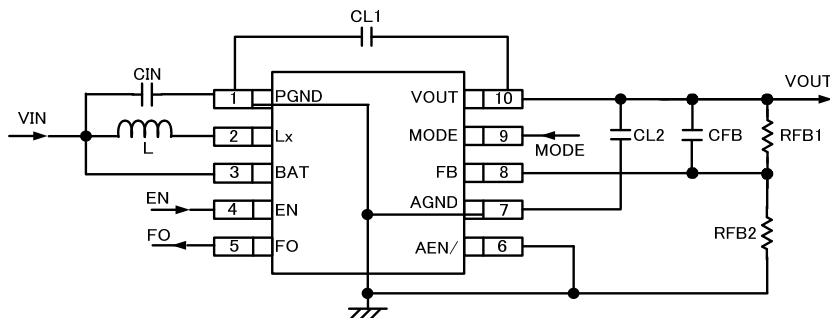

### <Output Voltage Setting>

Output voltage can be set by adding external split resistors. Output voltage is determined by the following equation, based on the values of  $R_{FB1}$  and  $R_{FB2}$ . The sum of  $R_{FB1}$  and  $R_{FB2}$  should normally be 500k $\Omega$  or less.

$$V_{OUT} = 0.45 \times (R_{FB1} + R_{FB2}) / R_{FB2}$$

The value of  $C_{FB}$ , speed-up capacitor for phase compensation, should be  $f_{ZFB} = 1 / (2 \times \pi \times C_{FB1} \times R_{FB1})$  which is in the range of 10 kHz to 50 kHz. Adjustments are depending on application, inductance (L), load capacitance (CL) and dropout voltage.

### [Example of calculation]

When  $R_{FB1} = 270\text{k}\Omega$ ,  $R_{FB2} = 43\text{k}\Omega$ ,

$$V_{OUT1} = 0.45 \times (270\text{k} + 43\text{k}) / 43\text{k} = 3.276\text{V}$$

### [Typical example]

VOUT (V)	RFB1 (k $\Omega$ )	RFB2 (k $\Omega$ )	CFB (pF)
1.8	300	100	10
2.5	270	59	12
3.3	270	43	12
5.0	180	17.8	15

### [External Components]

1.2MHz:

L : 4.7  $\mu$  H (CDRH4D28C SUMIDA)

CL1: 22  $\mu$  F (ceramic)

CL2: 10  $\mu$  F (ceramic)

CIN: 10 $\mu$ F (ceramic)

\*  $C_{L1}$  should be selected in 10 $\mu$ F or higher.

Capacitance  $C_{L1} + C_{L2}$  is recommended 30 $\mu$ F or higher. (Ceramic capacitor compatible)

If  $C_{L1}$  is lower than 10 $\mu$ F, operation may be unstable.

In case of the usage  $C_{L1} + C_{L2} < 30\mu\text{F}$ , output ripple may increase so that we recommend that you fully check actual performance on the board.

\* If using Tantalum or Electrolytic capacitors please be aware that ripple voltage will be higher due to the larger ESR (Equivalent Series Resistance) values of those types of capacitors. Please also note that the IC's operation may become unstable with such capacitors so we recommend that you fully check actual performance.

## OPERATIONAL EXPLANATION

The XC9128/XC9129 series consists of a reference voltage source, ramp wave circuit, error amplifier, PWM comparator, phase compensation circuit, N-channel driver transistor, P-channel synchronous rectification switching transistor and current limiter circuit. The error amplifier compares the internal reference voltage with the FB pin feed back voltage via resistors RFB1 and RFB2. Phase compensation is performed on the resulting error amplifier output, to input a signal to the PWM comparator to determine the turn-on time of the N-channel driver transistor during PWM operation. The PWM comparator compares, in terms of voltage level, the signal from the error amplifier with the ramp wave from the ramp wave circuit, and delivers the resulting output to the buffer driver circuit to cause the Lx pin to output a switching duty cycle. This process is continuously performed to ensure stable output voltage. The current feedback circuit monitors the N-channel driver transistor's turn-on current for each switching operation, and modulates the error amplifier output signal to provide multiple feedback signals. This enables a stable feedback loop even when a low ESR capacitor, such as a ceramic capacitor, is used, ensuring stable output voltage.

### <Reference Voltage Source>

The source provides the reference voltage to ensure stable output of the DC/DC converter.

### <Ramp Wave Circuit>

The ramp wave circuit determines switching frequency. The frequency is fixed internally at 1.2MHz. The Clock generated is used to produce ramp waveforms needed for PWM operation, and to synchronize all the internal circuits.

### <Error Amplifier>

The error amplifier is designed to monitor output voltage. The amplifier compares the reference voltage with the feedback voltage divided by the internal resistors (RFB1 and RFB2). When the FB pin is lower than the reference voltage, output voltage of the error amplifier increases. The gain and frequency characteristics of the error amplifier are optimized internally.

### < Maximum Current Limit>

The current limiter circuit monitors the maximum current flowing through the N-channel driver transistor connected to the Lx pin, and features a combination of the current limit and latch function.

- ① When the driver current is greater than a specific level (equivalent to peak coil current), the maximum current limit function starts to operate and the pulses from the Lx pin turn off the N-channel driver transistor at any given time.
- ② When the driver transistor is turned off, the limiter circuit is then released from the maximum current limit detection state.
- ③ At the next pulse, the driver transistor is turned on. However, the transistor is immediately turned off in the case of an over current state.
- ④ When the over current state is eliminated, the IC resumes its normal operation.

The XC9128B/XC9129B series waits for the over current state to end by repeating the steps ① through ③. If an over current state continues for several ms and the above three steps are repeatedly performed, the IC performs the function of latching the OFF state of the N-channel driver transistor, and goes into operation suspension mode. After being put into suspension mode, the IC can resume operation by turning itself off once and then re-starting via the EN pin, or by restoring power to the V<sub>IN</sub> pin.

The XC9128D/XC9129D series does not have this latch function, so operation steps ① through ③ repeat until the over current state ends.

Integral latch time may be released from a over current detection state because of the noise. Depending on the state of a substrate, it may result in the case where the latch time may become longer or the operation may not be latched. Please locate an input capacitor as close as possible.

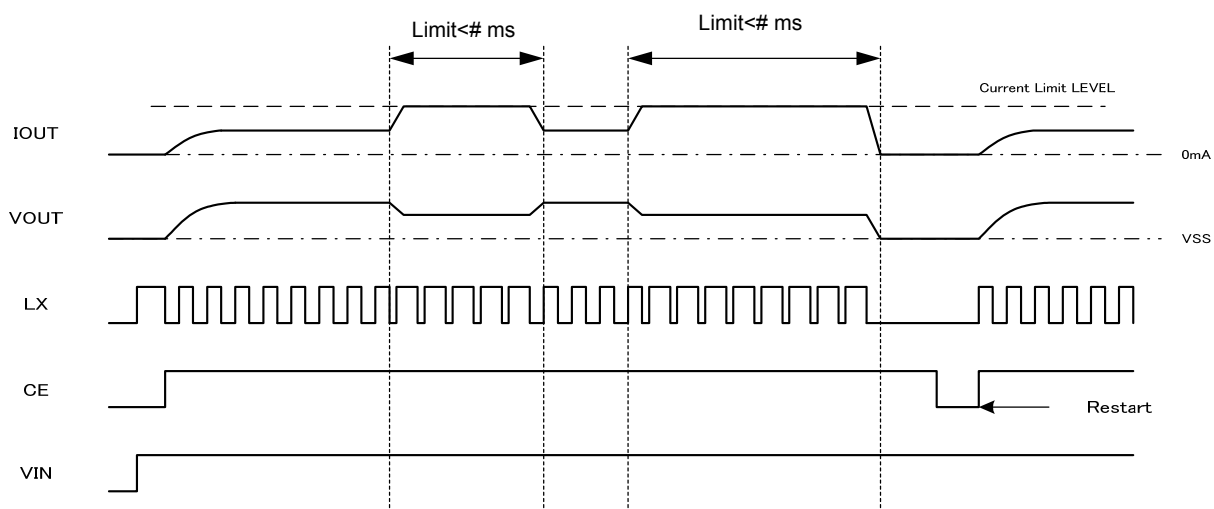



## ■ OPERATIONAL EXPLANATION (Continued)

### <Thermal Shutdown>

For protection against heat damage, the thermal shutdown function monitors chip temperature. When the chip's temperature reaches 150°C (TYP.), the thermal shutdown circuit starts operating and the driver transistor will be turned off. At the same time, the output voltage decreases. When the temperature drops to 130°C (TYP.) after shutting off the current flow, the IC performs the soft start function to initiate output startup operation.

### <MODE>

The MODE pin operates in PWM mode by applying a high level voltage and in PFM/PWM automatic switching mode by applying a low level voltage.

### <Shut-Down>

The IC enters chip disable state by applying low level voltage to the EN pin. At this time, the P-ch synchronous switching transistor turns on when  $V_{IN} > V_{OUT}$  and vice versa the transistor turns off when  $V_{IN} < V_{OUT}$ .

### <Adaptor Enable>

While the XC9128 series using step-up DC/DC converters in parallel with an added power source such as AC adaptors, the circuit needs the step-up DC/DC converter to be transient-efficient for sustaining output voltage in case the added power source runs down. The AEN/ pin voltage determines whether the added power source is supplied or not so that high-speed following operation is possible. The IC starts operating although the driver transistor is off when a high level voltage is applied to the AEN/ pin after a high level voltage is also applied to the EN pin. If the AEN/ pin voltage changes from high level to low level while the EN pin sustains a high level voltage, the step-up operation starts with high-speed following mode (without soft-start). The XC9129 series does not have adaptor enable function.

### <Error Flag >

For the XC9128 series, the FO pin becomes high impedance during over current state, over temperature state, soft-start period, and shut-down period.

The XC9129 series does not have flag out function.

## ■ NOTE ON USE

1. Please do not exceed the stated absolute maximum ratings values.
2. The DC/DC converter / controller IC's performance is greatly influenced by not only the ICs' characteristics, but also by those of the external components. Care must be taken when selecting the external components.
3. Make sure that the PCB GND traces are as thick as possible, as variations in ground potential caused by high ground currents at the time of switching may result in instability of the IC.
4. Please mount each external component as close to the IC as possible and use thick, short traces to reduce the circuit impedance.
5. When the device is used in high step-up ratio, the current limit function may not work during excessive load current. In this case, the maximum duty cycle limits maximum current.
6. When the adaptor enable function is used in the below circuit, please use a diode with low reverse bias current. The sum of  $R_{AEN1}$ 's and  $R_{AEN2}$ 's resistance should be set to manage the reverse bias current.

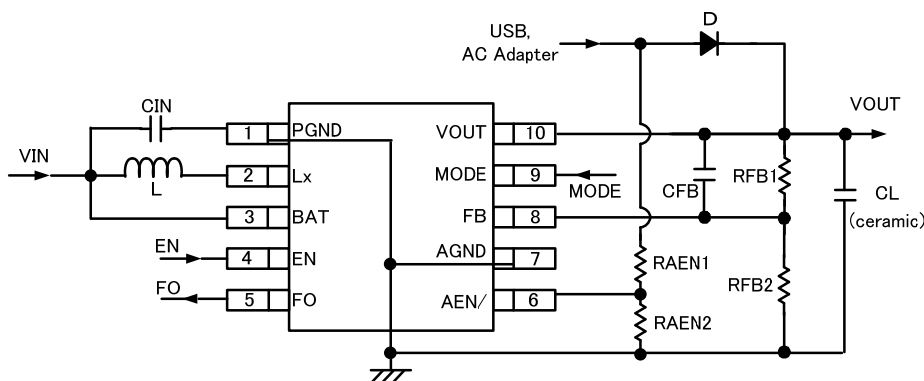

## NOTE ON USE (Continued)

### 7. P-ch synchronous switching transistor operation

The parasitic diode of the P-ch synchronous transistor is placed between Lx (anode) and V<sub>OUT</sub> (cathode), so that the power line can not be turned off from Lx to V<sub>OUT</sub>. On the other hand, the power line switch from V<sub>OUT</sub> to Lx is shown in the table below.

#### ●XC9128 Series

EN Pin	AEN/Pin	P-channel Synchronous Switch Transistor Operation
H	H	OFF
H	L	Switching
L	H	OFF
L	L	Undefined

#### ●XC9129 Series

EN Pin	P-channel Synchronous Switch Transistor Operation
H	Switching
L	Undefined

With the XC9128B/XC9129B series, when step-up operation stops as a result of the latch condition working when the maximum current limit level is reached, the synchronous P-channel transistor will remain ON.

8. The maximum current limiter controls the limit of the N-channel driver transistor by monitoring current flow. This function does not limit the current flow of the P-channel synchronous transistor.
9. The integral latch time of the XC9128B/XC9129B series could be released from the maximum current detection state as a result of board mounting conditions. This may extend integral latch time or the level required for latch operation to function may not be reached. Please connect the output capacitor as close to the IC as possible.
10. With the XC9128B/XC9129B series, when the EN pin is left open or applied in the range of 0.2V~0.65V, the integral latch or the V<sub>LVP</sub> may not be able to release. Please make sure that the EN pin voltage is less than 0.2V or more than 0.65V, or use the XC9128D/XC9129D series which does not have the integral latch and the LVP functions.
11. With the XC9128B/XC9129B series, please make the V<sub>OUT</sub> pin voltage become more than 1.5V within the soft-start time, otherwise the V<sub>LVP</sub> is detected. Also, the operation may become unstable, please test and verify the operation in the actual circuits thoroughly before use.
12. When used in small step-up ratios, the device may skip pulses during PWM control mode.

# TEST CIRCUITS \*1

< Circuit No.1 >

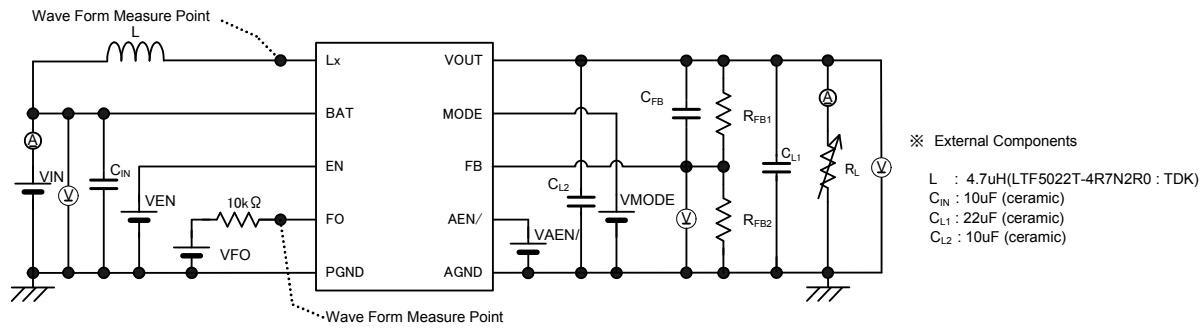

< Circuit No.2 >

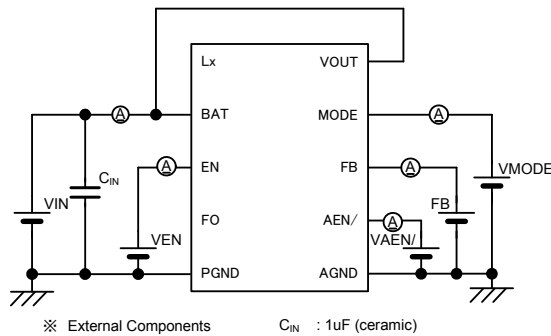

< Circuit No.3 >

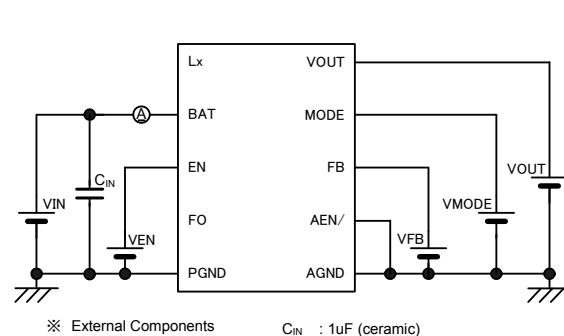

< Circuit No.4 >

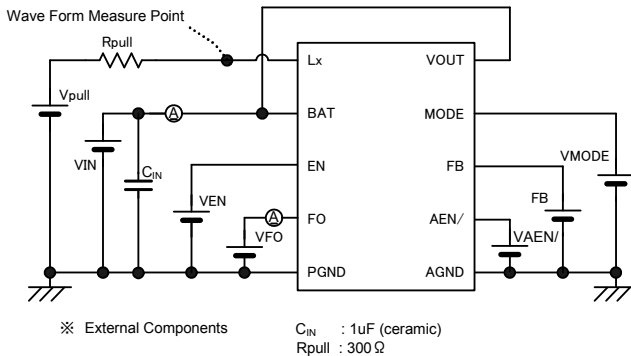

< Circuit No.5 >

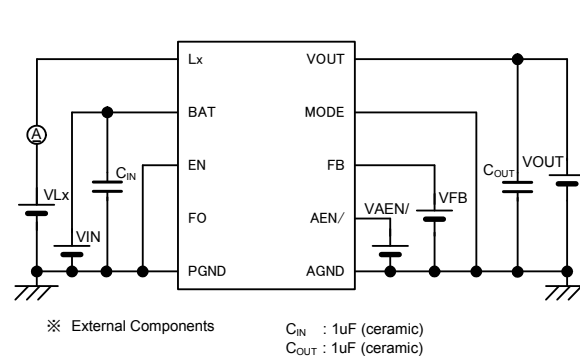

< Circuit No.6 >

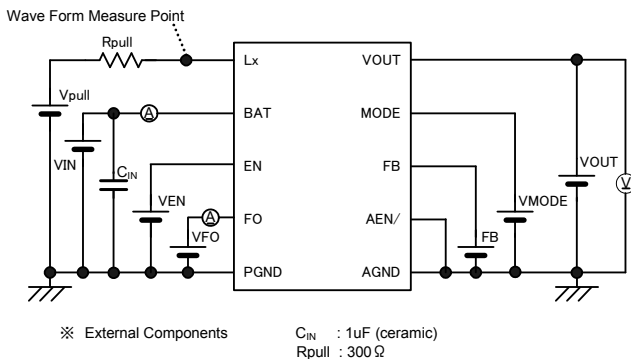

< Circuit No.7 >

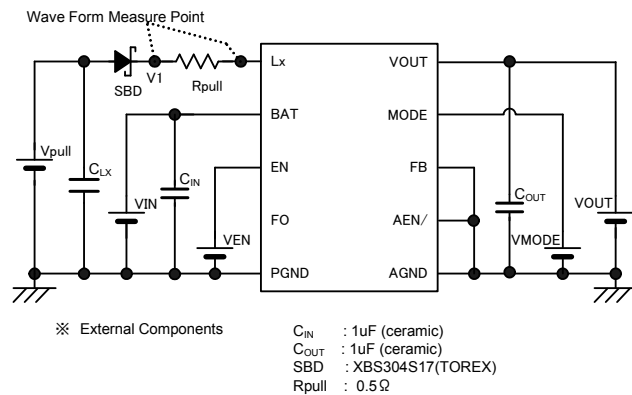

### Measurement method for ON resistance of the Lx switch

Using the layout of circuit No.7 above, set the L<sub>x</sub> pin voltage to 50mV by adjusting the V<sub>pull</sub> voltage whilst the N-ch driver transistor is turned on. Then, measure the voltage difference between both ends of R<sub>pull</sub>. ON Resistance is calculated by using the following formula:

$$R_{LXN} = 0.05 \div ((V1 - 0.05) \div 0.5)$$

where V1 is a voltage between SBD and R<sub>pull</sub>. L<sub>x</sub> pin voltage and V1 are measured by an oscilloscope.

\*1: The XC9129 series does not have the AEN/ pin and the FO pin. When the XC9129 series is measured, the FO and AEN pins are not effective in the above mentioned test circuits, they are NC.

# XC9128/XC9129 Series

## PACKAGING INFORMATION

### ●MSOP-10

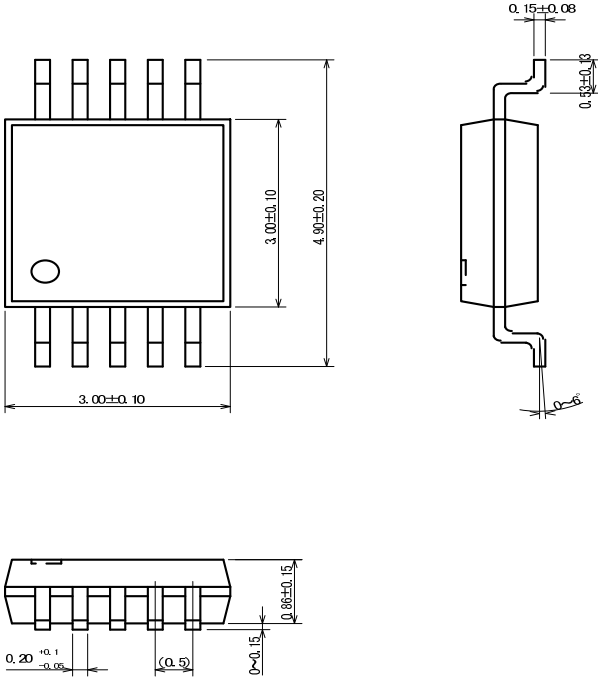

### ●USP-10B

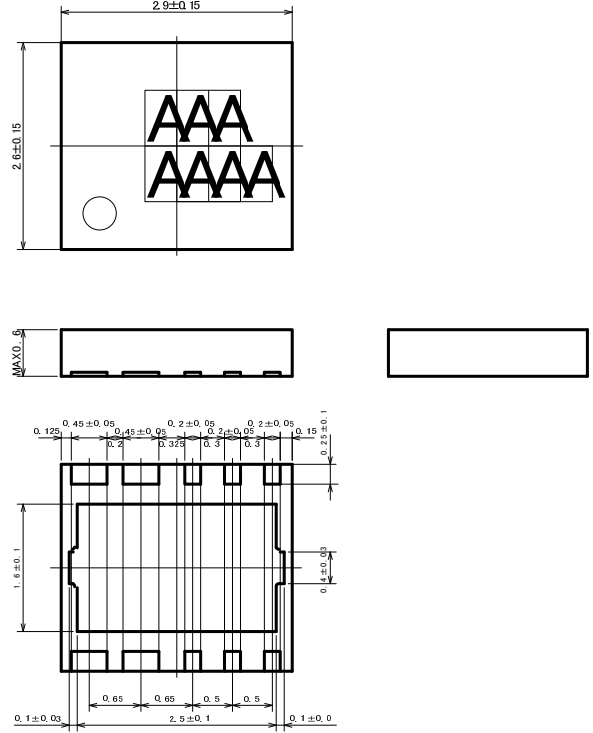

### ●SOP-8

(unit : mm)

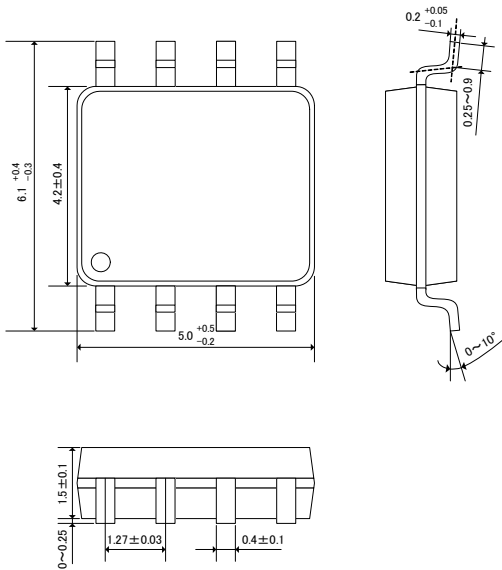

1. The products and product specifications contained herein are subject to change without notice to improve performance characteristics. Consult us, or our representatives before use, to confirm that the information in this datasheet is up to date.
2. We assume no responsibility for any infringement of patents, patent rights, or other rights arising from the use of any information and circuitry in this datasheet.
3. Please ensure suitable shipping controls (including fail-safe designs and aging protection) are in force for equipment employing products listed in this datasheet.
4. The products in this datasheet are not developed, designed, or approved for use with such equipment whose failure or malfunction can be reasonably expected to directly endanger the life of, or cause significant injury to, the user.  
(e.g. Atomic energy; aerospace; transport; combustion and associated safety equipment thereof.)
5. Please use the products listed in this datasheet within the specified ranges.  
Should you wish to use the products under conditions exceeding the specifications, please consult us or our representatives.
6. We assume no responsibility for damage or loss due to abnormal use.
7. All rights reserved. No part of this datasheet may be copied or reproduced without the prior permission of TOREX SEMICONDUCTOR LTD.

**TOREX SEMICONDUCTOR LTD.**