

**14,400 BPS Modem for Data, Fax, Voice**
**Description**

Xecom's XE1414A combines high-speed data and Group III send/receive fax in a compact component.

The XE1414A is not just a modem chip but a complete modem including the telephone interface. It provides user transferable FCC Part 68 registration and can connect directly to the telephone line through an RJ11 jack. The modem connects to the host through a TTL level serial interface. The XE1414A also includes MNP2-4 MNP10 and V.42 error control and MNP5 and V.42bis data compression

Xecom designed the XE1414A specifically to be embedded in commercial and industrial systems with a need for high-speed communications and minimal space.

**Features**

- Small Size; 2.75 " x 1.38" x 0.42"
- Modem control with "AT" commands
- Class 1 and Class 2 fax commands
- Data transfer up to 14,400 bps
- Send and receive fax to 14,400 bps
- MNP and V.42 Error Control
- MNP10 Error Control for Cellular Links
- MNP5 Data Compression to 28,800 bps
- V.42bis Data Compression to 57,600 bps
- Low power, single +5V supply  
Operating Power 600 mW (Typ.)  
Sleep mode: 30 mW (Typ.)
- NVRAM for modem configuration storage

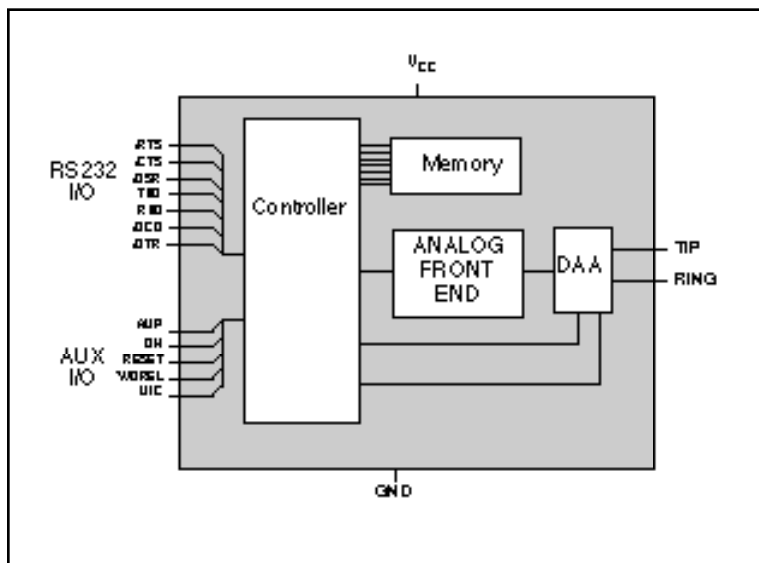
**Block Diagram**

**XE1414A Pin Configuration**

NC	1	40	VCC
NC	2	39	/DSR
RXD	3	38	/DCD
NC	4	37	NC
NC	5	36	RESET
NC	6	35	NC
NC	7	34	NC
NC	8	33	NC
/DTR	9	32	NC
NC	10	31	NC
/CTS	11	30	OH
NC	12	29	NC
TXD	13	28	NC
/RTS	14	27	NC
NC	15		
/RI	16		
TIP	18		
		22	AMP
RING	20	21	GND

## XE1414A Mechanical Specifications

PIN	INCHES		METRIC(MM)	
	MIN	MAX	MIN	MAX
A	2.74	2.760	69.60	70.10
B	1.370	1.390	34.80	35.31
C	0.420	0.430	10.67	10.92
D	1.190	1.210	30.23	30.73
E	1.890	1.910	48.01	48.51
F	0.125	0.200	3.18	5.08
G	0.080	0.100	2.03	2.54
H	0.415	0.435	10.54	11.05
J	0.090	0.110	2.29	2.79
K	0.020	0.025	0.51	0.64

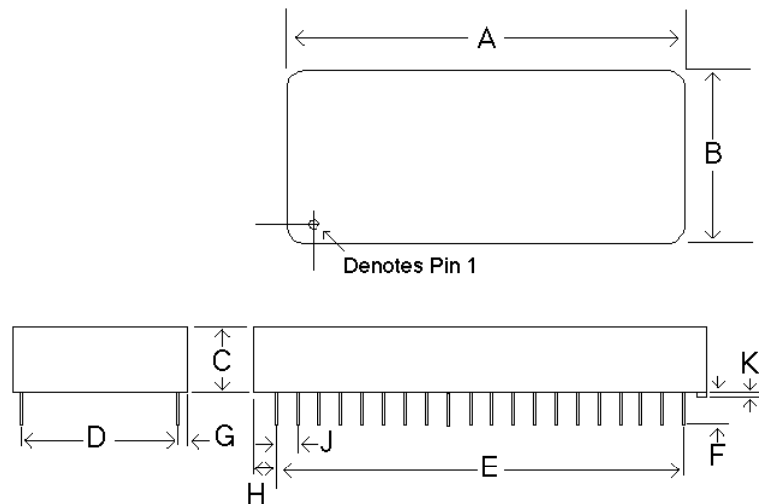
Pins = 0.025 inch square pin



Symbol	Parameter	Typ	Max	Units	Comments
Vcc	Supply Voltage	5.0	5.25	Volts	
Icc	Vcc Supply Current	120	150	mA	Active, On Line
		30		mA	Active, Idle
Iccs	Sleep Current	6.0	10.0	mA	Sleep Mode

**Power Management:** The XE1414A has an integrated power management capability. If no activity is detected on the RXD, DTR, or RI the modem will, within 5 seconds, automatically go into a smart sleep mode. In this mode power consumption is typically less than 50 milliwatts.

ABSOLUTE MAXIMUM RATINGS*	
SUPPLY VOLTAGE - Vcc	+6.5 Volts
DC INPUT VOLTAGE	-0.6 Volts to +6.5 Volts
STORAGE TEMPERATURE RANGE	-25° C TO +85° C
LEAD TEMPERATURE (Soldering, 2 sec per wave)	260° C
OPERATING TEMPERATURE RANGE	0 TO 70° C
*Exceeding these values may result in permanent damage to the device.	

## XE1414A Pin Descriptions

PIN	NAME	DESCRIPTION
3	RXD	Serial data output to the DTE (i.e. external UART). A logic "high" represents a "mark" and a logic "low" represents a "space", TTL.
9	\DTR	Data Terminal Ready, input, active Low, TTL. The function of this pin is set by the &D command. Normally the modem ignores DTR.
11	\CTS	Clear to Send, output, active Low, TTL/CMOS. This pin regulates the flow of data from the DTE during hardware flow control.
13	TXD	Serial data input from the DTE (i.e. external UART). A logic "high" represents a "mark" and a low represents a "space", TTL.
14	\RTS	Request to Send, input, active Low, TTL. This signal regulates the flow of data from the modem during hardware flow control.
16	\RI	Ring Indicator, output, active Low, TTL. When low indicates the modem is receiving a ring signal.
19	TIP	Tip connection to the phone line(RJ11 pin3) from the internal DAA.
20	RING	Ring connection to the phone line(RJ11 pin4) from the internal DAA. <b>Caution:</b>
21	GND	Ground (0 volts)
22	AMP	Audio output function is determined by L & M commands and the value in register S22. This output can drive a 300 ohm load.
30	OH	Oh is an active low output from the modem. Oh goes high when the modem is "off-hook." This signal can be used to drive an external relay to switch line usage between the modem and a handset.
36	RESET	Hardware reset pin, active High, TTL. Use of an external reset is not recommended. When not used Reset should be left open. Any signal applied to Pin 36 must remain high for a minimum of 100 milliseconds.
38	\DCD	Data Carrier Detect, output, active Low, TTL/CMOS. Function is set by the &C command and the value in register S21.
39	\DSR	Data Set Ready, output, active Low, TTL/CMOS. Function is set by the &S command and the value in register S21.
40	Vcc	+5 Volt power

## XE1414A Applications Schematic

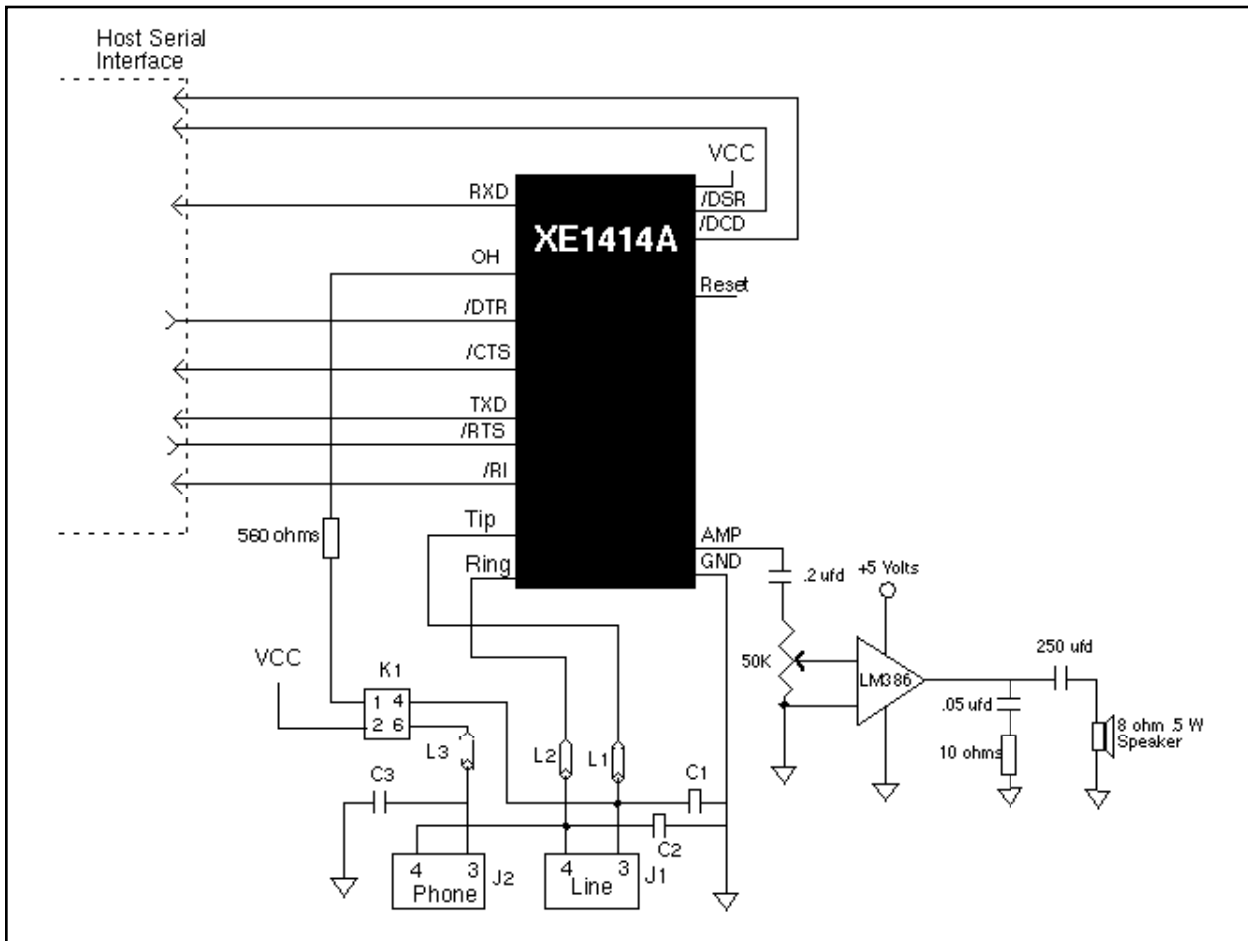

Note: RJ11 Pin assignments reflect a 6-pin connector. Tip and Ring are always the center pins of the RJ11 jack.

### Recommended Parts

Reference Designation	Recommended Part Number
L1, L2, L3	TDK CB30-1812
C1, C2, C3	Sprague 30GAT47, 470 pfd, 3000 Volts
J1, J2	Stewart SS6446NF
K1	Theta J LCB110

---

## AT Commands

The XE1414A uses "AT" commands for modem configuration and control. Extensions to the AT commands support fax and voice.

### Modes of Operation

The XE1414A has three operational modes; Command, Fax and Data.

**Data Mode:** The XE1414A enters data mode after it establishes a connection and issues a "CONNECT" result code. In the Data Mode the modem sends all signals on Transmit Data to the remote modem and puts data from the remote modem onto Received Data for the host equipment. When the modem exits data mode, it issues a "NO CARRIER" result code.

**Command Mode:** The XE1414A enters command mode on power-up, reset, loss of the connection, or receipt of the escape code. In command mode the modem accepts commands from the host on Transmit Data. Appropriate result codes are returned on Received Data.

**Fax Mode:** The XE1414A enters Class 1 fax mode on receipt of AT+FCLASS=1 and Class 2 fax mode on receipt of AT+FCLASS=2. In fax mode commands and responses are issued at 19,200 bits per second; the character format is 8 bits no parity. The modem accepts fax commands only in fax mode. The A/, ATO, AT&T and escape commands are not valid in fax mode.

### Command Line Format

Command lines issued to the modem follow a strict format. Each command begins with the prefix AT. The command line is stored in the command buffer and executed upon receipt of a carriage return. Until executed, the command line can be edited with the backspace key.

**Command Prefix** - The "A" and "T" of the command prefix may be both capitalized or both lower case but cannot be of different cases. The prefix identifies the speed and parity of the host. The modem determines speed by measuring the width of the incoming bits. Parity is determined by comparing the parity bits of the "A" and "T." The XE1414A normally sends result codes at the speed and parity determined by the prefix.

**Command Line** - Multiple commands may be placed in a command line. Commands are executed in the sequence they appear. Spaces may be inserted to improve legibility without filling space in the command buffer. A carriage return terminates the command line and causes the commands to be executed. Register S3 allows the user to select a character other than a carriage return to terminate the command line.

**Command Buffer** - Only 40 characters, including the AT prefix, may be loaded into the command buffer. If the command buffer overflows, the modem issues an "ERROR" result code and commands are not executed.

**Command Line Editing** - The backspace can be used to edit the command line. Hitting the backspace key, or Control and H simultaneously on some systems, erases the previous character in the command line. All of the characters can be erased except for the "A" and "T." Register S5 allows the user to select a character other than a backspace to edit the command line.

**Re-Execute Last Command** - The A/ command causes the modem to re-execute the last command line. This is the only command which does not require the "AT" prefix.

**Omitted Parameters** - Most commands include a parameter which determines the command function. When this parameter is omitted from the command string, it is assumed to be a 0.

**Escape Characters** - A three character escape sequence maybe entered while in data mode to switch the modem into command mode while remaining on line. The escape character, set by Register S2, must be entered 3 times in succession to execute the escape. The default escape sequence is "+++."

**Result Codes** - The modem issues a result code after each action. Result codes may be provided as full words, numeric codes or may be disabled all together. Each result code ends with a carriage return when numeric result codes are chosen. When full word result codes are chosen, a Line Feed and Carriage Return precede and follow each result code.

## XE1414A AT Command List

### A - Answer Command -

### Bn - Select Communications Standard

- n=0 Selects CCITT standards
- n=1 Selects Bell standards\*

### D - Dial Command -

- L = Re-dial last number
- P = Pulse dial
- T = Tone dial
- S=n = Dial stored number
- W = Wait for dial tone
- , = Pause for the duration ofr S8
- @ = Wait for silence
- ! = Switch hook flash
- ; = Return to the command state

### En - Command Echo

- n=0 Do not echo commands
- n=1 Enable command echo\*

### Fn - Select Line Modulation

- n=0 Auto-Detect\*
- n=1 300 bps (V.21 or Bel 103)
- n=3 V.23
- n=4 1200 bps (V.22 or Bell212A)
- n=5 2400 bps (V.22bis)
- n=6 4800 bps (V.32/V.32bis)
- n=7 7200 bps (V.32bis)
- n=8 9600 bps (V.32/V.32bis)
- n=9 12,000 bps (V.32bis)
- n=10 14,400 bps (V.32bis)

### Hn - Switch Hook Control -

- n=0 Switch hook relay opens\*
- n=1 The switch hook relay closes

### In - Modem Identification

### Ln - Speaker Volume -

- n=0 Lowest speaker volume
- n=1 Low speaker volume
- n=2 Moderate speaker volume\*
- n=3 High speaker volume

### Mn - Speaker Activity -

- n=0 Speaker off
- n=1 Speaker on until carrier received\*
- n=2 Speaker remains on
- n=3 Speaker on after dialing until carrier detected.

### Nn - Data Rate -

- n=0 Handshake only at DTE rate
- n=1 Initiate handshaking at Fn rate; Fallback if unsuccessful\*

### On - On Line

- n=0 Return On Line with no retrain\*
- n=1 Initiate retrain returning On Line.

### Qn - Responses

- n=0 Send responses\*
- n=1 No Responses

### Sr? - Interrogate Register -

### Sr=n - Set Register Value -

### Vn - Result Codes -

- n=0 Numeric Result Codes
- n=1 English Word Result Codes\*

### Wn - Connect Message Rate -

- n=0 Send "CONNECT" at DTE Rate\*
- n=1 Report line and DTE speed and Link protocol
- n=2 "CONNECT" Reports Link speed

### Xn - Result Code Set -

- n=0 Result codes 0 to 4
- n=1 Result codes 0 to 5 and 10
- n=2 Result codes 0 to 6 and 10
- n=3 Result codes 0 to 5, 7 and 10
- n=4 Full Result codes\*

### Yn - Long Space Disconnect -

- n=0 Long Space Disconnect Disabled\*
- n=1 Disconnect on long space

### Zn - Reset -

- n=0 Reset to user profile 0\*
- n=1 reset to user profile 1

## AT Command List (continued)

### **&Cn - DCD Operation**

- n=0 DCD is forced active.
- n=1 DCD indicates a valid carrier\*

### **&Dn - DTR**

- n=0 DTR is ignored by the modem.
- n=1 Modem switches to command mode when DTR revoked.
- n=2 Modem disconnects if DTR revoked.\*
- n=3 Perform soft reset when DTR revoked

### **&Fn - Return to Factory Defaults**

- n=0 Restore configuration 0\*
- n=1 Restore configuration 1

### **&Gn - Guard Tone**

- n=0 Guard Tone Disabled\*
- n=1 550 Hz Guard Tone
- n=2 1800 Hz Guard Tone

### **&Kn - Flow Control**

- n=0 Disabled
- n=3 RTS/CTS
- n=4 XON/XOFF
- n=5 Transparent XON/XOFF
- n=6 RTS/CTS and XON/XOFF

### **&Ln - Line Type**

- n=0 Dial-up line operation
- n=3 Dedicated (leased) line operation

### **&Pn - Dial Pulse Make/Break Ratio**

- n=0 39/61% @ 10 pps\*
- n=1 33/67% @ 10 pps
- n=2 39/61% @ 20 pps
- n=3 33/67% @ 20 pps

### **&Qn - Line Connection**

- n=0 Direct mode (no data buffering)\*
- n=5 Use Error Correction
- n=2 Normal Mode (Speed buffering)

### **&Sn - DSR Operation**

- n=0 DSR always active\*
- n=1 DSR in accordance with V.25.

### **&Tn - Test Modes**

- n=0 Exit test mode
- n=1 Local analog loopback
- n=3 Initiate local digital loopback
- n=4 Respond to remote loop request\*
- n=5 Deny remote loop request
- n=6 Initiate a Remote Digital loopback
- n=7 Remote digital loopback w self-test
- n=8 Local analog loopback w self-test

### **&Vn - View Configuration Profiles**

- n=0 View active profile & user profile 0\*
- n=1 View active profile & user profile 1

### **&Wn - Store Active Profile**

- n=0 Store active profile as profile 0\*
- n=1 Store active profile as profile 1

### **&Yn Default profile after reset.**

- n=0 Reset to Profile 0\*
- n=1 Reset to Profile 1

### **&Zn=x - Store telephone number "x" in memory location "n"**

### **%En - Line Quality Monitor/Auto Retrain**

- n=0 Disabled
- n=1 Enabled
- n=2 Enable line quality and fallback / fall forward

### **%L - Read Received Signal Level**

### **%Q - Read Line Signal Quality**

### **\An - MNP Block Size**

- n=0 Maximum 64 characters
- n=1 Maximum 128 characters
- n=2 Maximum 192 characters
- n=3 Maximum 256 characters\*

### **\Bn - Transmit Break**

### **\Gn - Set Modem Port Flow Control**

- n=0 Disables port flow control\*
- n=1 XON/XOFF port flow control

## AT Command List (continued)

### \Jn - DTE Rate Adjust

- n=0 Serial port speed independent of link speed\*
- n=1 Serial port automatically set to link speed\*

### \Kn - Break control

#### Break received from host with Reliable link.

- n=0 Enter on-line command mode; do not transmit break
- n=1 Purge buffers, immediately transmit break
- n=2 Same as n=0
- n=3 Immediately send break
- n=4 same as n=0
- n=5 Send break in sequence with buffered data\*

#### Break received from host with Direct link.

- n=0 Immediately transmit break, then enter on-line command mode
- n=1 Immediately send break
- n=2 Enter command mode but do not transmit break signal
- n=3 same as n=1
- n=4 same as n=0
- n=5 same as n=1\*

#### Break received from modem with Normal link.

- n=0 Purge buffers, Immediately send break to the host
- n=1 same as n=0
- n=2 Immediately send break to the host
- n=3 Same as n=2
- n=4 Send break to host in sequence with data.
- n=5 Same as n=2\*

#### Host initiates break (AT\b); Reliable link.

- n=0 Purge buffers; immediately transmit break
- n=1 Same as n=0
- n=2 Immediately transmit break
- n=3 Same as n=1
- n=4 Transmit break in sequence w data
- n=5 Same as n=4\*

### \Nn - Error Control Selection

- n=0 Normal mode, no error correction
- n=1 Direct mode, no buffering, no error correction
- n=2 Reliable mode, LAPM or MNP required
- n=3 V.42 Auto-reliable mode, accept either an error controlled or non-error controlled link\*
- n=4 V.42 Reliable mode, LAPM required
- n=5 MNP Reliable mode, MNP required

### \On - Originate Reliable Link

### \Qn - Flow Control Selection

- n=0 Disabled
- n=1 XON/XOFF Flow Control
- n=2 CTS Flow Control
- n=3 RTS/CTS Flow Control\*

### )Mn - Cellular Power Level Adjustment

- n=0 Disabled during MNP10 link negotiations
- n=1 Adjust power level during MNP10 link negotiations

### \*Hn - MNP10 Link Negotiation Speed

- n=0 Link negotiations occur at the highest supported speed
- n=1 Link negotiations at 1200 bps
- n=2 Link negotiations at 4800 bps

### -Kn - MNP Extended Services

- n=0 No LAPM to MNP10 conversion
- n=1 LAPM to MNP10 conversion\*
- n=2 LAPM to MNP10 conversion but no initiation of MNP Extended Service during V.42 LAPM answer mode detection.

### -Qn - Fallback to V.22bis/V.22

- n=0 Fallback enabled only to 4800 bps
- n=1 Fallback to 2400 bps or 1200 bps\*

### @Mn - Initial Cellular Transmit Level

- n=0 -26 dBm\*
- n=1 -30 dBm
- n=2-10 -10 dBm
- n=11 -11 dBm
- n=12 -12 dBm
- :
- :
- n=30 -30 dBmn
- n=31 -31 dBm

### :En - Compromise Equalizer

- n=0 Disabled
- n=1 Enabled\*



## XE1414A Class 1 Fax Command List

### **AT+FCLASS? - Service Class Indication**

- 0 = Configured as a data modem
- 1 = Configured for Service Class 1.

### **AT+FCLASS=? - Service Class Capability**

- 0 = Configured as a data modem
- 1 = Configured for Service Class 1.

### **AT+FCLASS=n - Set Service Class**

- 0 = Configured as a data modem
- 1 = Configured for Service Class 1.

### **AT+FAE=n - Data/Fax Auto Answer**

- 0 = Answer as a fax modem only
- 1 = Either a fax or data modem

### **AT+FF - Enhanced Flow Control**

### **AT+FRH<mod> - Receive HDLC Data**

- 3 V.21 Channel 2, 300 bps
- 24 V.27ter, 2400 bps
- 48 V.27ter, 4800 bps
- 72 V.29, 7200 bps
- 96 V.29, 9600 bps
- 97 V.17, 9600 bps
- 98 V.17 short train, 9600 bps
- 121 V.17, 12,000 bps
- 122 V.17 short train, 12,000 bps
- 145 V.17, 14,400 bps
- 146 V.17 short train, 14,400 bps

### **AT+FRM<mod> - Receive Fax** (see AT+FRH for "mod" values)

### **AT+FRS<time> - Receive Silence**

### **AT+FRTn - Receive Test Data**

### **AT+FTH<mod> - Transmit HDLC Data** (see AT+FRH for "mod" values)

### **AT+FTM<mod> - Transmit Fax** (see AT+FRH for "mod" values)

### **AT+FTS<time> - Transmit Silence**

### **AT+FTTn - Transmit Test Data**

## XE1414A Class 2 Fax Commands

<p><b>+FCLASS=n - Set Service Class</b>  n=0 Configured as a data modem  n=1 Configured for Service Class 1  n=2 Configured for Service Class 2  n=3 Reserved for Service Class 3</p> <p><b>+FCLASS=? - Available Service Class</b></p> <p><b>+FCLASS? - Current Service Class</b></p> <p><b>+FAA=n - Adaptive Answer</b>  n=0 Answer as selected Service Class  n=1 Answers as a data or fax modem.</p> <p><b>+FBOR=n - T.4 Data Bit Order</b>  n=0 Selects direct order for T.4 Data  n=1 Selects reverse order for T.4 data</p> <p><b>+FBUF? - Buffer Size</b></p> <p><b>+FCR=n - Capability to Receive</b>  n=0 Do not pass message data to host  n=1 Pass message data to host</p> <p><b>+FDCC = VR, BR, WD, LN, DF, ED, BF, ST -Set DCE Capabilities Parameters</b></p> <p><b>VR - Vertical Resolution</b>  0 98 Lines Per Inch (Normal)  1 196 Lines Per Inch (Fine)</p> <p><b>BR - Bit Rate</b>  0 2400 bits per second  1 4800 bits per second  2 7200 bits per second  3 9600 bits per second  4 12,000 bits per second  5 14,400 bits per second</p> <p><b>WD - Page Width</b>  0 1728 pixels in 215 millimeters  1 2048 pixels in 255 millimeters  2 2432 pixels in 303 millimeters</p> <p><b>LN - Page Length</b>  0 297 millimeters  1 364 millimeters  2 unlimited</p> <p><b>DF - Data Compression Format</b>  0 1-D modified Huffman  1 2-D modified Read</p>	<p><b>ED - Error Correction</b>  0 Disable Error Correction Mode  (Annex A of T.30)</p> <p><b>BF - Binary File Transfer</b>  0 Disable Binary File Transfer  1 Enable Binary File Transfer</p> <p><b>ST - Scan Time per Line</b></p> <table style="width: 100%; border-collapse: collapse;"> <thead> <tr> <th></th> <th style="text-align: center;"><u>Normal Resolution</u></th> <th style="text-align: center;"><u>Fine Resolution</u></th> </tr> </thead> <tbody> <tr><td>0</td><td style="text-align: center;">0 milliseconds</td><td style="text-align: center;">0 milliseconds</td></tr> <tr><td>1</td><td style="text-align: center;">5 milliseconds</td><td style="text-align: center;">5 milliseconds</td></tr> <tr><td>2</td><td style="text-align: center;">10 milliseconds</td><td style="text-align: center;">5 milliseconds</td></tr> <tr><td>3</td><td style="text-align: center;">10 milliseconds</td><td style="text-align: center;">10 milliseconds</td></tr> <tr><td>4</td><td style="text-align: center;">20 milliseconds</td><td style="text-align: center;">10 milliseconds</td></tr> <tr><td>5</td><td style="text-align: center;">20 milliseconds</td><td style="text-align: center;">20 milliseconds</td></tr> <tr><td>6</td><td style="text-align: center;">40 milliseconds</td><td style="text-align: center;">20 milliseconds</td></tr> <tr><td>7</td><td style="text-align: center;">40 milliseconds</td><td style="text-align: center;">40 milliseconds</td></tr> </tbody> </table> <p><b>+FAXERR - Fax Error Value</b></p> <table style="width: 100%; border-collapse: collapse;"> <thead> <tr> <th style="text-align: left;"><u>Code</u></th> <th style="text-align: left;"><u>Disconnect Cause</u></th> </tr> </thead> <tbody> <tr><td>0</td><td>Normal fax disconnect</td></tr> <tr><td>1</td><td>Ring detected but handshake unsuccessful</td></tr> <tr><td>2</td><td>Call terminated by the host</td></tr> <tr><td>3</td><td>No telephone loop current</td></tr> <tr><td>10</td><td>Phase A handshaking error</td></tr> <tr><td>11</td><td>No answer, time out</td></tr> <tr><td>20</td><td>Transmit Phase B error</td></tr> <tr><td>21</td><td>Remote cannot receive or send</td></tr> <tr><td>22</td><td>Command error transmit Phase B</td></tr> <tr><td>23</td><td>Invalid command received</td></tr> <tr><td>24</td><td>Response Errors</td></tr> <tr><td>25</td><td>Local capabilities sent 3 times, no response</td></tr> <tr><td>26</td><td>local capabilities not recognized</td></tr> <tr><td>27</td><td>Failed to train at lowest speed</td></tr> <tr><td>28</td><td>Invalid response received</td></tr> <tr><td>40</td><td>T.4 transmit data error</td></tr> <tr><td>43</td><td>No data from host</td></tr> <tr><td>50</td><td>Transmit Phase D error</td></tr> <tr><td>51</td><td>Invalid Response received in transmit Phase D</td></tr> <tr><td>52</td><td>No response to next page message, 3 attempts</td></tr> <tr><td>53</td><td>Invalid response to the next page message</td></tr> <tr><td>54</td><td>No response to End of Page message, 3 attempts</td></tr> <tr><td>55</td><td>Invalid response to end of page message</td></tr> <tr><td>56</td><td>No response to End of Message after 3 attempts</td></tr> <tr><td>57</td><td>Invalid response to End of Message</td></tr> <tr><td>58</td><td>Unable to continue after page interrupt</td></tr> </tbody> </table>		<u>Normal Resolution</u>	<u>Fine Resolution</u>	0	0 milliseconds	0 milliseconds	1	5 milliseconds	5 milliseconds	2	10 milliseconds	5 milliseconds	3	10 milliseconds	10 milliseconds	4	20 milliseconds	10 milliseconds	5	20 milliseconds	20 milliseconds	6	40 milliseconds	20 milliseconds	7	40 milliseconds	40 milliseconds	<u>Code</u>	<u>Disconnect Cause</u>	0	Normal fax disconnect	1	Ring detected but handshake unsuccessful	2	Call terminated by the host	3	No telephone loop current	10	Phase A handshaking error	11	No answer, time out	20	Transmit Phase B error	21	Remote cannot receive or send	22	Command error transmit Phase B	23	Invalid command received	24	Response Errors	25	Local capabilities sent 3 times, no response	26	local capabilities not recognized	27	Failed to train at lowest speed	28	Invalid response received	40	T.4 transmit data error	43	No data from host	50	Transmit Phase D error	51	Invalid Response received in transmit Phase D	52	No response to next page message, 3 attempts	53	Invalid response to the next page message	54	No response to End of Page message, 3 attempts	55	Invalid response to end of page message	56	No response to End of Message after 3 attempts	57	Invalid response to End of Message	58	Unable to continue after page interrupt
	<u>Normal Resolution</u>	<u>Fine Resolution</u>																																																																																
0	0 milliseconds	0 milliseconds																																																																																
1	5 milliseconds	5 milliseconds																																																																																
2	10 milliseconds	5 milliseconds																																																																																
3	10 milliseconds	10 milliseconds																																																																																
4	20 milliseconds	10 milliseconds																																																																																
5	20 milliseconds	20 milliseconds																																																																																
6	40 milliseconds	20 milliseconds																																																																																
7	40 milliseconds	40 milliseconds																																																																																
<u>Code</u>	<u>Disconnect Cause</u>																																																																																	
0	Normal fax disconnect																																																																																	
1	Ring detected but handshake unsuccessful																																																																																	
2	Call terminated by the host																																																																																	
3	No telephone loop current																																																																																	
10	Phase A handshaking error																																																																																	
11	No answer, time out																																																																																	
20	Transmit Phase B error																																																																																	
21	Remote cannot receive or send																																																																																	
22	Command error transmit Phase B																																																																																	
23	Invalid command received																																																																																	
24	Response Errors																																																																																	
25	Local capabilities sent 3 times, no response																																																																																	
26	local capabilities not recognized																																																																																	
27	Failed to train at lowest speed																																																																																	
28	Invalid response received																																																																																	
40	T.4 transmit data error																																																																																	
43	No data from host																																																																																	
50	Transmit Phase D error																																																																																	
51	Invalid Response received in transmit Phase D																																																																																	
52	No response to next page message, 3 attempts																																																																																	
53	Invalid response to the next page message																																																																																	
54	No response to End of Page message, 3 attempts																																																																																	
55	Invalid response to end of page message																																																																																	
56	No response to End of Message after 3 attempts																																																																																	
57	Invalid response to End of Message																																																																																	
58	Unable to continue after page interrupt																																																																																	

## Class 2 Fax Commands (continued)

Error Code	Disconnect Cause
70	Unspecified phase B error
71	Receive Response Error
72	Command received error
73	T.30 time out, expected page not received
74	T.30 time out after end of message received
90	Unspecified Phase C Error
91	Missing End of line after 5 seconds
93	Receive Buffer overflow
94	Bad check sum of frame
100	Receive Phase D errors
101	Invalid response received
102	Invalid command received
103	Unable to continue after page interrupt

<b>+FDCS? - Current Session Results</b>
<b>+FDIS =VR, BR, WD, LN, DF, ED, BF, ST - Set Current Sessions Capabilities Parameters</b>
<b>+FDR - Begin/Continue Phase C Receive Data</b>
<b>+FDT - Data Transmission</b>
<b>+FET=&lt;ppm&gt; - Transmit Page Punctuation</b>
<b>+FK - Terminate Session</b>
<b>+FLID&lt;local ID&gt;= - Local ID String</b>
<b>+FPHCTO &lt;value&gt;- Phase C Time Out</b>

## XE1414A S-Register Summary

Register	Range	Units	Description	Default
S0	0-255	rings	Number of rings before initiating automatic answer sequence	000
S1	0-255	rings	Count number of incoming rings	000
S2	0-127	-	ASCII Escape character	043
S3	0-127	-	ASCII Carriage return character	013
S4	0-127	-	ASCII Line feed character	010
S5	0-32,127	-	ASCII Backspace character	008
S6	2-255	sec	Wait for Dial tone before Blind Dialing	002
S7	1-60	sec	Wait time to detect remote carrier	050
S8	0-255	sec	Duration of pause created by comma in the command string	002
S9	1-255	0.1 sec	Duration of carrier required for recognition as valid Carrier	006
S10	1-255	0.1 sec	Delay from loss of carrier to hang up	014
S11	50-255	msec	DTMF dialing speed	095
S12	0-255	0.02 sec	TIES Escape Code Time Limit	050
S18	0-255	sec	Duration of internal Modem tests.	000
S24	Bit Mapped	-	Sleep Mode timer	010
S30	0-255	10msec	Duration of inactivity on TXD & RXD before automatic Disconnect	000
S32	0-255	-	ASCII XON Character for in-band Flow Control	017
S33	0-255	-	ASCII XOFF Character for in-band Flow Control	019
S37	Bit Mapped	-	Maximum Link Speed	000
S46	136/138	-	Data Compression Control	138
S48	0,7,128	-	V.42 Negotiations	007

## XE1414A Result Codes

DIGIT	FULL	DEFINITIONS
0	OK	Successfully executed command line
1	CONNECT	300 bps connection established
2	RING	Ring signal detected
3	NO CARRIER	Carrier not detected or Carrier lost
4	ERROR	Error found in command line; returns to command mode
5	CONNECT 1200	1200 bps connection established
6	NO DIAL TONE	No dial tone detected within 5 Sec. after going off-hook
7	BUSY	Busy signal detected after automatically dialing a call
8	NO ANSWER	5 seconds of silence not detected
10	CONNECT 2400	Connection established with 2400 bps link or DTE speed
11	CONNECT 4800	Connection established with 4800 bps link or DTE speed
12	CONNECT 9600	Connection established with 9600 bps link or DTE speed
13	CONNECT 7200	Connection established with 7200 bps link or DTE speed
14	CONNECT 12000	Connection established with 12,000 bps link or DTE speed
15	CONNECT 14400	Connection established with 14,400 bps link or DTE speed
16	CONNECT 19200	Connection established with 19,200 bps DTE speed
17	CONNECT 38400	Connection established with 38,400 bps DTE speed
18	CONNECT 57600	Connection established with 57,600 bps DTE speed
22	CONNECT 75TX/1200RX	V.23 originate connection established
23	CONNECT 1200TX/75RX	V.23 answer connection established
33	FAX	Fax connection established
34	DATA	Data connection established in Fax mode
40	CARRIER 300	300 bps carrier received
44	CARRIER 1200/75	V.23 reverse channel carrier received
45	CARRIER 75/1200	V.23 forward channel carrier received
46	CARRIER 1200	1200 bps carrier received
47	CARRIER 2400	2400 bps carrier received
48	CARRIER 4800	4800 bps carrier received
49	CARRIER 7200	7200 bps carrier received
50	CARRIER 9600	9600 bps carrier received
51	CARRIER 12000	12,000 bps carrier received
52	CARRIER 14400	14,400 bps carrier received
66	COMPRESSION: CLASS 5	MNP Class 5 data compression has been established
67	COMPRESSION: V.42bis	V.42bis data compression has been established
69	COMPRESSION: NONE	The link was established without data compression
70	PROTOCOL: NONE	The link was established without error correction
77	PROTOCOL: LAPM	The link was established with LAPM error correction
80	PROTOCOL: ALT	The link was established with MNP error correction
+F4	+FCERROR	Fax carrier error detected

## XE1414A Electrical Specifications

Parameter	Min	Typ	Max	Unit	Comments
DTMF Level		-2.2	0	dBm	3 second average
Modem Transmit Level	-12	-10.5	-9.0	dBm	600 ohm line
Pulse Dialing Rate			10	pps	
Pulse Dialing Make/Break		39/61		%	USA
Billing Delay Interval	2.0			sec.	
Phone Line Impedance Match		600		ohms	
Ring Detect Sensitivity	38		150	VRMS	Type B Ringer
Telephone Loop Current	0	20	100	milliamps	Off-hook
Input High Voltage (TXD, RTS, DTR)	2.0			Volts	
Input Low Voltage (TXD, RTS, DTR)			0.8	Volts	
Output High Voltage (DCD, DSR, CTS, RXD, RI, OH)	2.4			Volts	RXD -100 microamps; DCD, RI, OH - 1.6 mamps
Output Low Voltage (DCD, DSR, CTS, RXD, RI, OH)			0.4	Volts	RXD - 1.6 milliamps; DCD, RI, OH - 6 milliamps
Output Drive Current (OH)			10	milliamps	

---

## FCC Instructions

This product complies with Part 68 of the FCC Rules and Regulations. Each device shipped includes a label which contains the FCC Registration Number and Ringer Equivalence (REN). If requested, this FCC information must be provided to the telephone company. A registration label must be affixed to the cabinet's exterior for each device mounted within a closed assembly.

Ringer Equivalence (REN) is used to calculate the number of devices you may connect to one telephone line and still have all of the devices respond to an incoming call. Typically, the sum of the RENs of all devices connected to one line should not exceed five (5.0). Contact your local telephone company to determine the maximum REN for your area.

Mount this device in the final assembly so as to prevent exposure to any hazardous voltages in the system and to preserve the high voltage protection between Tip/Ring and the rest of the system. Installation must provide adequate separation and restraint of cables and cords. Xecom recommends maintaining a minimum of .100 inches between the Tip and Ring traces and all other circuits. No circuitry may be added between Tip/Ring and the telephone line connection unless specifically allowed by the rules.

This device requires use of an RSOC RJ-11C jack for the telephone line connection. The jack selected must be certified to meet FCC Part 68 subpart F requirements.

If you experience trouble with this device, contact XECOM at (408)945-6640 to obtain service. There are no repairs the customer may make to this device. If your system causes harm to the telephone network, the telephone company may discontinue service temporarily until the problem has been corrected or it is demonstrated that the device is not malfunctioning. If possible, you will be notified in advance that service is being discontinued. If advance notice is not practical, you will be notified as soon as possible.

Your telephone company may make changes to their facilities, equipment, or operation that affect proper functioning of your equipment. You will be notified in advance of such changes to give you the opportunity to maintain uninterrupted telephone service.

This device cannot be used on coin operated telephone lines provided by the telephone company. Connection of this equipment to party lines is subject to state tariffs.

Any one using this device for fax transfer must include sender identification information as required in the Telephone Consumer Protection Act of 1991. The Telephone Consumer Protection Act of 1991 makes it unlawful to send a fax without clearly identifying the fax sender (business or individual) and the number of the transmitting fax machine. This information may be provided either on the first page of the fax or in the top or bottom margin of each page. The number listed may not be a 900 number or other number for which charges exceed local or long distance transmission.

The final assembler must provide these FCC instructions to the end user of the equipment.

---

## Terms of Sale

Devices sold by XECOM are covered by the warranty provisions appearing in its Terms of Sale only. XECOM makes no warranty, express, statutory, implied, or by description regarding the information set forth herein, or regarding the freedom of the described devices from patent infringement. XECOM makes no warranty of merchantability or fitness for any purposes. XECOM reserves the right to discontinue production and change specifications and prices at any time and without notice. This product is intended for use in normal commercial applications. Applications requiring extended temperature range, unusual environmental requirements, or high reliability applications, such as military, medical life-support or life-sustaining equipment, are specifically not recommended without additional processing and authorization by XECOM for such application.

Xecom assumes no responsibility for the use of any circuitry other than circuitry embodied in a Xecom product. No other circuits, patents, or licenses are implied.

## Life Support Policy

Xecom's products are not authorized for use as Critical Components in Life Support Devices or Systems.

**Life Support Devices or Systems** are devices or systems which, (a) are intended for surgical implant into the body, or (b) support or sustain life, and whose failure to perform, when properly used in accordance with instructions provided in the labeling, can be reasonably expected to result in significant injury to the user.

**A Critical Component** is any component of a life support device or system whose failure to perform can be reasonably expected to cause failure of the life support device or system, or to affect its safety or effectiveness.

Copyright, Xecom © 1997

While Xecom, Inc. has made every effort to ensure that the information presented here is accurate, Xecom will not be liable for any damages arising from errors or omission of fact. Xecom reserves the right to modify specifications and/or prices without notice. Product mentioned herein are used for identification purposes only and may be trademarks and/or registered trademarks of their respective companies.

The logo for XECOM, featuring the word "XECOM" in a bold, white, sans-serif font. The letters are set against a black rectangular background with a thin white border.

Xecom Incorporated  
374 Turquoise Street, Milpitas, CA 95035  
Ph:408-945-6640 Fax:408-942-1346 E-Mail: info@xecom.com