

GENERAL DESCRIPTION

The XRT86L30 is a single channel 1.544 Mbit/s or 2.048 Mbit/s DS1/E1/J1 framer and LIU integrated solution featuring R³ technology (Relayless, Reconfigurable, Redundancy). The physical interface is optimized with internal impedance, and with the patented pad structure, the XRT86L30 provides protection from power failures and hot swapping.

The XRT86L30 contains an integrated DS1/E1/J1 framer and LIU which provide DS1/E1/J1 framing and error accumulation in accordance with ANSI/ITU_T specifications. The framer has a framing synchronizer and transmit-receive slip buffers. The slip buffers can be independently enabled or disabled as required and can be configured to frame to the common DS1/E1/J1 signal formats.

The Framer block contains a Transmit and Receive T1/E1/J1 Framing function. There are 3 Transmit HDLC controllers which encapsulate contents of the Transmit HDLC buffers into LAPD Message frames. There are 3 Receive HDLC controllers which extract the payload content of Receive LAPD Message

frames from the incoming T1/E1/J1 data stream and write the contents into the Receive HDLC buffers. The framer also contains a Transmit and Overhead Data Input port, which permits Data Link Terminal Equipment direct access to the outbound T1/E1/J1 frames. Likewise, a Receive Overhead output data port permits Data Link Terminal Equipment direct access to the Data Link bits of the inbound T1/E1/J1 frames.

The XRT86L30 fully meets all of the latest T1/E1/J1 specifications: ANSI T1/E1.107-1988, ANSI T1/E1.403-1999, ANSI T1/E1.231-1993, ANSI T1/E1.408-1990, AT&T TR 62411 (12-90) TR54016, and ITU G-703, G.704, G.706 and G.733, AT&T Pub. 43801, and ETS 300 011, 300 233, JT G.703, JT G.704, JT G.706, I.431. Extensive test and diagnostic functions include Loop-backs, Boundary scan, Pseudo Random bit sequence (PRBS) test pattern generation, Performance Monitor, Bit Error Rate (BER) meter, forced error insertion, and LAPD unchannelized data payload processing according to ITU-T standard Q.921.

Applications and Features (next page)

FIGURE 1. XRT86L30 1-CHANNEL DS1 (T1/E1/J1) FRAMER/LIU COMBO

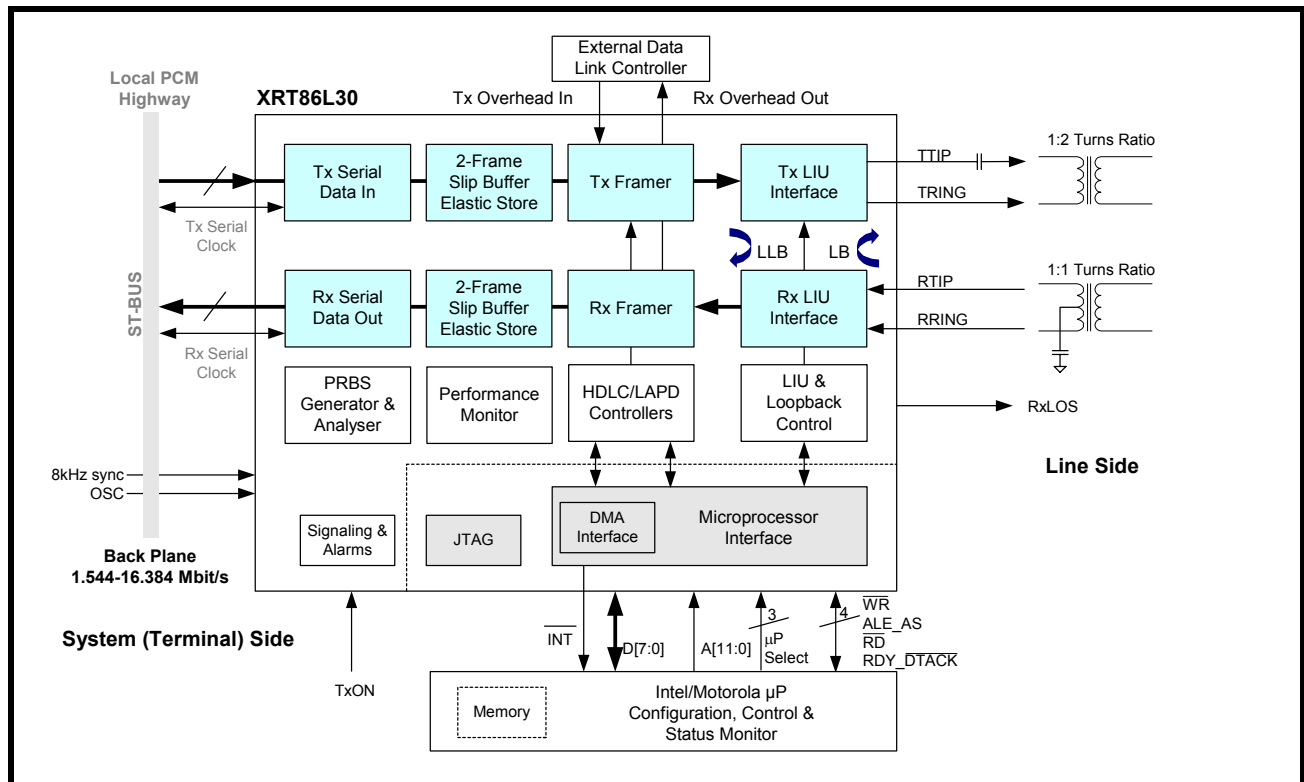

APPLICATIONS

- High-Density T1/E1/J1 interfaces for Multiplexers, Switches, LAN Routers and Digital Modems
- SONET/SDH terminal or Add/Drop multiplexers (ADMs)
- T1/E1/J1 add/drop multiplexers (MUX)
- Channel Service Units (CSUs): T1/E1/J1 and Fractional T1/E1/J1
- Digital Access Cross-connect System (DACs)
- Digital Cross-connect Systems (DCS)
- Frame Relay Switches and Access Devices (FRADS)
- ISDN Primary Rate Interfaces (PRA)
- PBXs and PCM channel bank
- T3 channelized access concentrators and M13 MUX
- Wireless base stations
- ATM equipment with integrated DS1 interfaces
- Multichannel DS1 Test Equipment
- T1/E1/J1 Performance Monitoring
- Voice over packet gateways
- Routers

FEATURES

- Full duplex DS1 Tx and Rx Framer/LIU
- Two 512-bit (two-frame) elastic store, PCM frame slip buffers (FIFO) on TX and Rx provide up to 8.192 MHz asynchronous back plane connections with jitter and wander attenuation
- Supports input PCM and signaling data at 1.544, 2.048, 4.096 and 8.192 Mbits. Also supports 4-channel multiplexed 12.352/16.384 (HMVIP/H.100) Mbit/s on the back plane bus (with stuffed don't care bits for the other 3 channels)
- Programmable output clocks for Fractional T1/E1/J1
- Supports Channel Associated Signaling (CAS)
- Supports Common Channel Signalling (CCS)
- Supports ISDN Primary Rate Interface (ISDN PRI) signaling
- Extracts and inserts robbed bit signaling (RBS)
- 3 Integrated HDLC controllers for transmit and receive, each controller having two 96-byte buffers (buffer 0 / buffer 1)
- HDLC Controllers Support SS7
- Timeslot assignable HDLC
- V5.1 or V5.2 Interface
- Automatic Performance Report Generation (PMON Status) can be inserted into the transmit LAPD interface every 1 second or for a single transmission
- Alarm Indication Signal with Customer Installation signature (AIS-CI)
- Remote Alarm Indication with Customer Installation (RAI-CI)
- Gapped Clock interface mode for Transmit and Receive.
- Intel/Motorola and Power PC interfaces for configuration, control and status monitoring
- Parallel search algorithm for fast frame synchronization
- Wide choice of T1 framing structures: SF/D4, ESF, SLC@96, T1DM and N-Frame (non-signaling)

- Direct access to D and E channels for fast transmission of data link information
- PRBS, QRSS, and Network Loop Code generation and detection
- Programmable Interrupt output pin
- Supports programmed I/O and DMA modes of Read-Write access
- Each framer block encodes and decodes the T1/E1/J1 Frame serial data
- Detects and forces Red (SAI), Yellow (RAI) and Blue (AIS) Alarms
- Detects OOF, LOF, LOS errors and COFA conditions
- Loopbacks: Local (LLB) and Line remote (LB)
- Facilitates Inverse Multiplexing for ATM
- Performance monitor with one second polling
- Boundary scan (IEEE 1149.1) JTAG test port
- Accepts external 8kHz Sync reference
- 3.3V CMOS operation with 5V tolerant inputs
- 128-pin TQFP package with -40°C to +85°C operation

ORDERING INFORMATION

PART NUMBER	PACKAGE	OPERATING TEMPERATURE RANGE
XRT86L30IB	128 TQFP	-40°C to +85°C

LIST OF PARAGRAPHS

1.0 PIN LIST	4
2.0 PIN DESCRIPTIONS	5
3.0 MICROPROCESSOR INTERFACE BLOCK	18
3.0.1 THE MICROPROCESSOR INTERFACE BLOCK SIGNALS	18
3.1 INTEL MODE PROGRAMMED I/O ACCESS (ASYNCHRONOUS)	21
3.2 MOTOROLA MODE PROGRAMMED I/O ACCESS (SYNCHRONOUS)	23
3.2.1 DMA READ/WRITE OPERATIONS	25
3.3 MEMORY MAPPED I/O ADDRESSING	27
3.4 DESCRIPTION OF THE CONTROL REGISTERS	28
3.4.1 REGISTER DESCRIPTIONS	34
3.5 PROGRAMMING THE LINE INTERFACE UNIT (LIU SECTION)	115
3.6 THE INTERRUPT STRUCTURE WITHIN THE FRAMER	133
3.6.1 CONFIGURING THE INTERRUPT SYSTEM, AT THE FRAMER LEVEL	136
4.0 GENERAL DESCRIPTION AND INTERFACE	139
4.1 PHYSICAL INTERFACE	139
4.2 R3 TECHNOLOGY (RELAYLESS / RECONFIGURABLE / REDUNDANCY)	140
4.2.1 LINE CARD REDUNDANCY	140
4.2.2 TYPICAL REDUNDANCY SCHEMES	140
4.2.3 1:1 AND 1+1 REDUNDANCY WITHOUT RELAYS	140
4.2.4 TRANSMIT INTERFACE WITH 1:1 AND 1+1 REDUNDANCY	140
4.2.5 RECEIVE INTERFACE WITH 1:1 AND 1+1 REDUNDANCY	141
4.3 POWER FAILURE PROTECTION	142
4.4 OVERVOLTAGE AND OVERCURRENT PROTECTION	142
4.5 NON-INTRUSIVE MONITORING	142
4.6 T1/E1 SERIAL PCM INTERFACE	143
4.7 T1/E1 FRACTIONAL INTERFACE	144
4.8 T1/E1 TIME SLOT SUBSTITUTION AND CONTROL	145
4.9 ROBBED BIT SIGNALING/CAS SIGNALING	146
4.10 OVERHEAD INTERFACE	148
4.11 FRAMER BYPASS MODE	149
4.12 HIGH-SPEED NON-MULTIPLEXED INTERFACE	150
4.13 HIGH-SPEED MULTIPLEXED INTERFACE	151
5.0 LOOPBACK MODES OF OPERATION	152
5.1 LIU PHYSICAL INTERFACE LOOPBACK DIAGNOSTICS	152
5.1.1 LOCAL ANALOG LOOPBACK	152
5.1.2 REMOTE LOOPBACK	152
5.1.3 DIGITAL LOOPBACK	153
5.1.4 DUAL LOOPBACK	153
5.1.5 FRAMER REMOTE LINE LOOPBACK	153
5.1.6 FRAMER PAYLOAD LOOPBACK	154
5.1.7 FRAMER LOCAL LOOPBACK	154
6.0 HDLC CONTROLLERS AND LAPD MESSAGES	155
6.1 PROGRAMMING SEQUENCE FOR SENDING LESS THAN 96-BYTE MESSAGES	155
6.2 PROGRAMMING SEQUENCE FOR SENDING LARGE MESSAGES	155
6.3 PROGRAMMING SEQUENCE FOR RECEIVING LAPD MESSAGES	156
6.4 SS7 (SIGNALING SYSTEM NUMBER 7) FOR ESF IN DS1 ONLY	156
6.5 DS1/E1 DATALINK TRANSMISSION USING THE HDLC CONTROLLERS	157
6.6 TRANSMIT BOS (BIT ORIENTED SIGNALING) PROCESSOR	157
6.6.1 DESCRIPTION OF BOS	157
6.6.2 PRIORITY CODEWORD MESSAGE	157
6.6.3 COMMAND AND RESPONSE INFORMATION	157
6.7 TRANSMIT MOS (MESSAGE ORIENTED SIGNALING) PROCESSOR	158
6.7.1 DISCUSSION OF MOS	158
6.7.2 PERIODIC PERFORMANCE REPORT	158
6.7.3 TRANSMISSION-ERROR EVENT	159
6.7.4 PATH AND TEST SIGNAL IDENTIFICATION MESSAGE	159
6.7.5 FRAME STRUCTURE	159
6.7.6 FLAG SEQUENCE	159
6.7.7 ADDRESS FIELD	160
6.7.8 ADDRESS FIELD EXTENSION BIT (EA)	160

6.7.9 COMMAND OR RESPONSE BIT (C/R)	160
6.7.10 SERVICE ACCESS POINT IDENTIFIER (SAPI)	160
6.7.11 TERMINAL ENDPOINT IDENTIFIER (TEI)	160
6.7.12 CONTROL FIELD	160
6.7.13 FRAME CHECK SEQUENCE (FCS) FIELD	160
6.7.14 TRANSPARENCY (ZERO STUFFING)	161
6.8 TRANSMIT SLC@96 DATA LINK CONTROLLER	162
6.9 D/E TIME SLOT TRANSMIT HDLC CONTROLLER BLOCK V5.1 OR V5.2 INTERFACE	163
6.10 AUTOMATIC PERFORMANCE REPORT (APR)	163
6.10.1 BIT VALUE INTERPRETATION	163
7.0 OVERHEAD INTERFACE BLOCK	165
7.1 DS1 TRANSMIT OVERHEAD INPUT INTERFACE BLOCK	165
7.1.1 DESCRIPTION OF THE DS1 TRANSMIT OVERHEAD INPUT INTERFACE BLOCK	165
7.1.2 CONFIGURE THE DS1 TRANSMIT OVERHEAD INPUT INTERFACE MODULE AS SOURCE OF THE FACILITY DATA LINK (FDL) BITS IN ESF FRAMING FORMAT MODE	165
7.1.3 CONFIGURE THE DS1 TRANSMIT OVERHEAD INPUT INTERFACE MODULE AS SOURCE OF THE SIGNALING FRAMING (FS) BITS IN N OR SLC@96 FRAMING FORMAT MODE	167
7.1.4 CONFIGURE THE DS1 TRANSMIT OVERHEAD INPUT INTERFACE MODULE AS SOURCE OF THE REMOTE SIGNALING (R) BITS IN T1DM FRAMING FORMAT MODE	168
7.2 DS1 RECEIVE OVERHEAD OUTPUT INTERFACE BLOCK	168
7.2.1 DESCRIPTION OF THE DS1 RECEIVE OVERHEAD OUTPUT INTERFACE BLOCK	169
7.2.2 CONFIGURE THE DS1 RECEIVE OVERHEAD OUTPUT INTERFACE MODULE AS DESTINATION OF THE FACILITY DATA LINK (FDL) BITS IN ESF FRAMING FORMAT MODE	169
7.2.3 CONFIGURE THE DS1 RECEIVE OVERHEAD OUTPUT INTERFACE MODULE AS DESTINATION OF THE SIGNALING FRAMING (FS) BITS IN N OR SLC@96 FRAMING FORMAT MODE	170
7.2.4 CONFIGURE THE DS1 RECEIVE OVERHEAD OUTPUT INTERFACE MODULE AS DESTINATION OF THE REMOTE SIGNALING (R) BITS IN T1DM FRAMING FORMAT MODE	171
7.3 E1 OVERHEAD INTERFACE BLOCK	172
7.4 E1 TRANSMIT OVERHEAD INPUT INTERFACE BLOCK	172
7.4.1 DESCRIPTION OF THE E1 TRANSMIT OVERHEAD INPUT INTERFACE BLOCK	172
7.4.2 CONFIGURE THE E1 TRANSMIT OVERHEAD INPUT INTERFACE MODULE AS SOURCE OF THE NATIONAL BIT SEQUENCE IN E1 FRAMING FORMAT MODE	173
7.5 E1 RECEIVE OVERHEAD INTERFACE	175
7.5.1 DESCRIPTION OF THE E1 RECEIVE OVERHEAD OUTPUT INTERFACE BLOCK	175
7.5.2 CONFIGURE THE E1 RECEIVE OVERHEAD OUTPUT INTERFACE MODULE AS SOURCE OF THE NATIONAL BIT SEQUENCE IN E1 FRAMING FORMAT MODE	176
8.0 LIU TRANSMIT PATH	178
8.1 TRANSMIT DIAGNOSTIC FEATURES	178
8.1.1 TAOS (TRANSMIT ALL ONES)	178
8.1.2 ATAOS (AUTOMATIC TRANSMIT ALL ONES)	179
8.1.3 NETWORK LOOP UP CODE	179
8.1.4 NETWORK LOOP DOWN CODE	179
8.1.5 QRSS GENERATION	180
8.2 T1 LONG HAUL LINE BUILD OUT (LBO)	180
8.3 T1 SHORT HAUL LINE BUILD OUT (LBO)	181
8.3.1 ARBITRARY PULSE GENERATOR	181
8.3.2 DMO (DIGITAL MONITOR OUTPUT)	182
8.3.3 TRANSMIT JITTER ATTENUATOR	182
8.4 LINE TERMINATION (TTIP/TRING)	183
9.0 LIU RECEIVE PATH	184
9.1 LINE TERMINATION (RTIP/RRING)	184
9.1.1 CASE 1: INTERNAL TERMINATION	184
9.1.2 CASE 2: INTERNAL TERMINATION WITH ONE EXTERNAL FIXED RESISTOR FOR ALL MODES	184
9.1.3 EQUALIZER CONTROL	185
9.1.4 CABLE LOSS INDICATOR	185
9.2 RECEIVE SENSITIVITY	186
9.2.1 AIS (ALARM INDICATION SIGNAL)	186
9.2.2 NLCD (NETWORK LOOP CODE DETECTION)	186
9.2.3 FLSD (FIFO LIMIT STATUS DETECTION)	187
9.2.4 RECEIVE JITTER ATTENUATOR	187
9.2.5 RXMUTE (RECEIVER LOS WITH DATA MUTING)	187
10.0 THE E1 TRANSMIT/RECEIVE FRAMER	189
10.1 DESCRIPTION OF THE TRANSMIT/RECEIVE PAYLOAD DATA INPUT INTERFACE BLOCK	189
10.1.1 BRIEF DISCUSSION OF THE TRANSMIT/RECEIVE PAYLOAD DATA INPUT INTERFACE BLOCK OPERATING AT	

XRT84V24 COMPATIBLE 2.048MBIT/S MODE	189
10.2 TRANSMIT/RECEIVE HIGH-SPEED BACK-PLANE INTERFACE	192
10.2.1 NON-MULTIPLEXED HIGH-SPEED MODE	192
10.2.2 MULTIPLEXED HIGH-SPEED MODE	195
10.3 BRIEF DISCUSSION OF COMMON CHANNEL SIGNALING IN E1 FRAMING FORMAT	201
10.4 BRIEF DISCUSSION OF CHANNEL ASSOCIATED SIGNALING IN E1 FRAMING FORMAT	201
10.5 INSERT/EXTRACT SIGNALING BITS FROM TSCR REGISTER	201
10.6 INSERT/EXTRACT SIGNALING BITS FROM TXCHN[0]_N/TXSIG PIN	201
10.7 ENABLE CHANNEL ASSOCIATED SIGNALING AND SIGNALING DATA SOURCE CONTROL	202
11.0 THE DS1 TRANSMIT/RECEIVE FRAMER	203
11.1 DESCRIPTION OF THE TRANSMIT/RECEIVE PAYLOAD DATA INPUT INTERFACE BLOCK	203
11.1.1 BRIEF DISCUSSION OF THE TRANSMIT/RECEIVE PAYLOAD DATA INPUT INTERFACE BLOCK OPERATING AT 1.544MBIT/S MODE	203
11.2 TRANSMIT/RECEIVE HIGH-SPEED BACK-PLANE INTERFACE	206
11.2.1 T1 TRANSMIT/RECEIVE INTERFACE - MVIP 2.048 MHZ	206
11.2.2 NON-MULTIPLEXED HIGH-SPEED MODE	207
11.2.3 MULTIPLEXED HIGH-SPEED MODE	209
11.3 BRIEF DISCUSSION OF ROBBED-BIT SIGNALING IN DS1 FRAMING FORMAT	215
11.3.1 CONFIGURE THE FRAMER TO TRANSMIT ROBBED-BIT SIGNALING	215
11.3.2 INSERT SIGNALING BITS FROM TSCR REGISTER	216
11.3.3 INSERT SIGNALING BITS FROM TXSIG_N PIN	216
12.0 ALARMS AND ERROR CONDITIONS	218
12.1 AIS ALARM	218
12.2 RED ALARM	220
12.3 YELLOW ALARM	221
12.4 BIPOLAR VIOLATION	223
12.5 E1 BRIEF DISCUSSION OF ALARMS AND ERROR CONDITIONS	226
12.5.1 HOW TO CONFIGURE THE FRAMER TO TRANSMIT AIS	231
12.5.2 HOW TO CONFIGURE THE FRAMER TO GENERATE RED ALARM	232
12.5.3 HOW TO CONFIGURE THE FRAMER TO TRANSMIT YELLOW ALARM	232
12.5.4 TRANSMIT YELLOW ALARM	233
12.5.5 TRANSMIT CAS MULTI-FRAME YELLOW ALARM	233
12.6 T1 BRIEF DISCUSSION OF ALARMS AND ERROR CONDITIONS	234
12.6.1 HOW TO CONFIGURE THE FRAMER TO TRANSMIT AIS	237
12.6.2 HOW TO CONFIGURE THE FRAMER TO GENERATE RED ALARM	238
12.6.3 HOW TO CONFIGURE THE FRAMER TO TRANSMIT YELLOW ALARM	238
12.6.4 TRANSMIT YELLOW ALARM IN SF MODE	239
12.6.5 TRANSMIT YELLOW ALARM IN ESF MODE	239
12.6.6 TRANSMIT YELLOW ALARM IN N MODE	239
12.6.7 TRANSMIT YELLOW ALARM IN T1DM MODE	239
13.0 PERFORMANCE MONITORING (PMON)	242
13.1 RECEIVE LINE CODE VIOLATION COUNTER (16-BIT)	242
13.2 16-BIT RECEIVE FRAME ALIGNMENT ERROR COUNTER (16-BIT)	242
13.3 RECEIVE SEVERELY ERRORED FRAME COUNTER (8-BIT)	242
13.4 RECEIVE CRC-6/4 BLOCK ERROR COUNTER (16-BIT)	242
13.5 RECEIVE FAR-END BLOCK ERROR COUNTER (16-BIT)	242
13.6 RECEIVE SLIP COUNTER (8-BIT)	242
13.7 RECEIVE LOSS OF FRAME COUNTER (8-BIT)	242
13.8 RECEIVE CHANGE OF FRAME ALIGNMENT COUNTER (8-BIT)	242
13.9 FRAME CHECK SEQUENCE ERROR COUNTERS 1, 2, AND 3 (8-BIT EACH)	242
13.10 PRBS ERROR COUNTER (16-BIT)	242
13.11 TRANSMIT SLIP COUNTER (8-BIT)	242
13.12 EXCESSIVE ZERO VIOLATION COUNTER (16-BIT)	243
14.0 APPENDIX A: DS-1/E1 FRAMING FORMATS	244
14.1 THE E1 FRAMING STRUCTURE	244
14.1.1 FAS FRAME	244
14.1.2 NON-FAS FRAME	245
14.2 THE E1 MULTI-FRAME STRUCTURE	246
14.2.1 THE CRC MULTI-FRAME STRUCTURE	246
14.2.2 CAS MULTI-FRAMES AND CHANNEL ASSOCIATED SIGNALING	248
14.3 THE DS1 FRAMING STRUCTURE	250
14.4 T1 SUPER FRAME FORMAT (SF)	251

14.5 T1 EXTENDED SUPERFRAME FORMAT (ESF)	253
14.6 T1 NON-SIGNALING FRAME FORMAT	255
14.7 T1 DATA MULTIPLEXED FRAMING FORMAT (T1DM)	255
14.8 SLC-96 FORMAT (SLC-96)	256

LIST OF FIGURES

Figure 1.: XRT86L30 1-channel DS1 (T1/E1/J1) Framer/LIU Combo 1

Figure 2.: Simplified Block Diagram of the Microprocessor Interface Block 18

Figure 3.: Intel μ P Interface Signals During Programmed I/O Read and Write Operations 22

Figure 4.: Motorola μ P Interface Signals During Programmed I/O Read and Write Operations 24

Figure 5.: Motorola 68K μ P Interface Signals During Programmed I/O Read and Write Operations 25

Figure 6.: DMA Mode for the XRT86L30 and a Microprocessor 26

Figure 7.: LIU Transmit Connection Diagram Using Internal Termination 139

Figure 8.: LIU Receive Connection Diagram Using Internal Termination 139

Figure 9.: Simplified Block Diagram of the Transmit Interface for 1:1 and 1+1 Redundancy 140

Figure 10.: Simplified Block Diagram of the Receive Interface for 1:1 and 1+1 Redundancy 141

Figure 11.: Simplified Block Diagram of a Non-Intrusive Monitoring Application 142

Figure 12.: Transmit T1/E1 Serial PCM Interface 143

Figure 13.: Receive T1/E1 Serial PCM Interface 143

Figure 14.: T1 Fractional Interface 144

Figure 15.: T1/E1 Time Slot Substitution and Control 145

Figure 16.: Robbed Bit Signaling / CAS Signaling 146

Figure 17.: ESF / CAS External Signaling Bus 146

Figure 18.: SF / SLC-96 or 4-code Signaling in ESF / CAS External Signaling Bus 147

Figure 19.: T1/E1 Overhead Interface 148

Figure 20.: T1 External Overhead Datalink Bus 148

Figure 21.: E1 Overhead External Datalink Bus 149

Figure 22.: Simplified Block Diagram of the Framer Bypass Mode 149

Figure 23.: T1 High-Speed Non-Multiplexed Interface 150

Figure 24.: E1 High-Speed Non-Multiplexed Interface 150

Figure 25.: Transmit High-Speed Bit Multiplexed Block Diagram 151

Figure 26.: Receive High-Speed Bit Multiplexed Block Diagram 151

Figure 27.: Simplified Block Diagram of Local Analog Loopback 152

Figure 28.: Simplified Block Diagram of Remote Loopback 152

Figure 29.: Simplified Block Diagram of Digital Loopback 153

Figure 30.: Simplified Block Diagram of Dual Loopback 153

Figure 31.: Simplified Block Diagram of the Framer Remote Line Loopback 153

Figure 32.: Simplified Block Diagram of the Framer Local Loopback 154

Figure 33.: Simplified Block Diagram of the Framer Local Loopback 154

Figure 34.: HDLC Controllers 155

Figure 35.: LAPD Frame Structure 158

Figure 36.: Block Diagram of the DS1 Transmit Overhead Input Interface of the XRT86L30 165

Figure 37.: DS1 Transmit Overhead Input Interface Timing in ESF Framing Format mode 167

Figure 38.: DS1 Transmit Overhead Input Timing in N or SLC[®]96 Framing Format Mode 168

Figure 39.: DS1 Transmit Overhead Input Interface module in T1DM Framing Format mode 168

Figure 40.: Block Diagram of the DS1 Receive Overhead Output Interface of XRT86L30 169

Figure 41.: DS1 Receive Overhead Output Interface module in ESF framing format mode 170

Figure 42.: DS1 Receive Overhead Output Interface Timing in N or SLC[®]96 Framing Format mode 171

Figure 43.: DS1 Receive Overhead Output Interface Timing in T1DM Framing Format mode 172

Figure 44.: Block Diagram of the E1 Transmit Overhead Input Interface of XRT86L30 173

Figure 45.: E1 Transmit Overhead Input Interface Timing 175

Figure 46.: Block Diagram of the E1 Receive Overhead Output Interface of XRT86L30 175

Figure 47.: E1 Receive Overhead Output Interface Timing 177

Figure 48.: TAOS (Transmit All Ones) 178

Figure 49.: Simplified Block Diagram of the ATAOS Function 179

Figure 50.: Network Loop Up Code Generation 179

Figure 51.: Network Loop Down Code Generation 179

Figure 52.: Long Haul Line Build Out with -7.5dB Attenuation 180

Figure 53.: Long Haul Line Build Out with -15dB Attenuation 180

Figure 54.: Long Haul Line Build Out with -22.5dB Attenuation 181

Figure 55.: Arbitrary Pulse Segment Assignment 182

Figure 56.: Typical Connection Diagram Using Internal Termination 183

Figure 57.: Typical Connection Diagram Using Internal Termination 184

Figure 58.: Typical Connection Diagram Using One External Fixed Resistor 185

Figure 59.: Simplified Block Diagram of the Equalizer and Peak Detector	185
Figure 60.: Simplified Block Diagram of the Cable Loss Indicator	185
Figure 61.: Test Configuration for Measuring Receive Sensitivity	186
Figure 62.: Process Block for Automatic Loop Code Detection	187
Figure 63.: Simplified Block Diagram of the RxMUTE Function	188
Figure 64.: Interfacing the Transmit Path to local terminal equipment	189
Figure 66.: Waveforms for connecting the Transmit Payload Data Input Interface Block to local Terminal Equipment	190
Figure 65.: Interfacing the Receive Path to local terminal equipment	190
Figure 67.: Waveforms for connecting the Receive Payload Data Input Interface Block to local Terminal Equipment .	191
Figure 68.: Transmit Non-Multiplexed High-Speed Connection to local terminal equipment using MVIP 2.048Mbit/s, 4.096Mbit/s, or 8.192Mbit/s	192
Figure 70.: Waveforms for Connecting the Transmit Non-Multiplexed High-Speed Input Interface at MVIP 2.048Mbit/s, 4.096Mbit/s, and 8.192Mbit/s	193
Figure 69.: Receive Non-Multiplexed High-Speed Connection to local terminal equipment using MVIP 2.048Mbit/s, 4.096Mbit/s, or 8.192Mbit/s	193
Figure 71.: Waveforms for Connecting the Receive Non-Multiplexed High-Speed Input Interface at MVIP 2.048Mbit/s, 4.096Mbit/s, and 8.192Mbit/s	194
Figure 72.: Interfacing XRT86L30 Transmit to local terminal equipment using 16.384Mbit/s, HMVIP 16.384Mbit/s, and H.100 16.384Mbit/s	197
Figure 73.: Interfacing XRT86L30 Receive to local terminal equipment using 16.384Mbit/s, HMVIP 16.384Mbit/s, and H.100 16.384Mbit/s	198
Figure 74.: Waveforms for Connecting the Transmit Multiplexed High-Speed Input Interface at HMVIP And H.100 16.384Mbit/s mode	199
Figure 75.: Waveforms for Connecting the Receive Multiplexed High-Speed Input Interface at HMVIP 16.384Mbit/s mode 199	199
Figure 76.: Waveforms for Connecting the Receive Multiplexed High-Speed Input Interface at H.100 16.384Mbit/s mode 200	200
Figure 77.: Timing Diagram of the TxSIG Input	201
Figure 78.: Timing Diagram of the RxSIG Output	202
Figure 79.: Interfacing the Transmit Path to local terminal equipment	203
Figure 81.: Waveforms for connecting the Transmit Payload Data Input Interface Block to local Terminal Equipment	204
Figure 80.: Interfacing the Receive Path to local terminal equipment	204
Figure 82.: Waveforms for connecting the Receive Payload Data Input Interface Block to local Terminal Equipment .	205
Figure 83.: Transmit Non-Multiplexed High-Speed Connection to local terminal equipment using MVIP 2.048Mbit/s, 4.096Mbit/s, or 8.192Mbit/s	207
Figure 84.: Receive Non-Multiplexed High-Speed Connection to local terminal equipment using MVIP 2.048Mbit/s, 4.096Mbit/s, or 8.192Mbit/s	207
Figure 85.: Waveforms for Connecting the Transmit Non-Multiplexed High-Speed Input Interface at MVIP 2.048Mbit/s, 4.096Mbit/s, and 8.192Mbit/s	208
Figure 86.: Waveforms for Connecting the Receive Non-Multiplexed High-Speed Input Interface at MVIP 2.048Mbit/s, 4.096Mbit/s, and 8.192Mbit/s	208
Figure 87.: Interfacing XRT86L30 Transmit to local terminal equipment using 16.384Mbit/s, HMVIP 16.384Mbit/s, and H.100 16.384Mbit/s	211
Figure 88.: Interfacing XRT86L30 Receive to local terminal equipment using 16.384Mbit/s, HMVIP 16.384Mbit/s, and H.100 16.384Mbit/s	212
Figure 89.: Waveforms for Connecting the Transmit Multiplexed High-Speed Input Interface at 12.352Mbit/s mode ..	212
Figure 91.: Waveforms for Connecting the Transmit Multiplexed High-Speed Input Interface at HMVIP and H.100 16.384Mbit/s mode	213
Figure 92.: Waveforms for Connecting the Receive Multiplexed High-Speed Input Interface at 12.352Mbit/s mode ...	213
Figure 90.: Waveforms for Connecting the Transmit Multiplexed High-Speed Input Interface at 16.384Mbit/s mode ..	213
Figure 95.: Waveforms for Connecting the Receive Multiplexed High-Speed Input Interface at H.100 16.384Mbit/s mode 214	214
Figure 93.: Waveforms for Connecting the Receive Multiplexed High-Speed Input Interface at 16.384Mbit/s mode ...	214
Figure 94.: Waveforms for Connecting the Receive Multiplexed High-Speed Input Interface at HMVIP 16.384Mbit/s mode 214	214
Figure 96.: Timing Diagram of the TxSig_n Input	217
Figure 97.: Simple Diagram of E1 system model	226
Figure 98.: Generation of Yellow Alarm by the Repeater upon detection of line failure	227
Figure 99.: Generation of AIS by the Repeater upon detection of line failure	228
Figure 100.: Generation of Yellow Alarm by the CPE upon detection of AIS originated by the Repeater	229

SINGLE T1/E1/J1 FRAMER/LIU COMBO

Figure 101.: Generation of CAS Multi-frame Yellow Alarm and AIS16 by the Repeater 230

Figure 102.: Generation of CAS Multi-frame Yellow Alarm by the CPE upon detection of “AIS16” pattern sent by the Repeater
231

Figure 103.: Simple Diagram of DS1 System Model 234

Figure 104.: Generation of Yellow Alarm by the CPE upon detection of line failure 235

Figure 105.: Generation of AIS by the Repeater upon detection of Yellow Alarm originated by the CPE 236

Figure 106.: Generation of Yellow Alarm by the CPE upon detection of AIS originated by the Repeater 237

Figure 107.: Single E1 Frame Diagram 244

Figure 108.: Frame/Byte Format of the CAS Multi-Frame Structure 248

Figure 109.: E1 Frame Format 249

Figure 110.: T1 Frame Format 250

Figure 111.: T1 Superframe PCM Format 251

Figure 112.: T1 Extended Superframe Format 253

Figure 113.: T1DM Frame Format 255

Figure 114.: Framer System Transmit Timing Diagram 258

Figure 115.: Framer System Receive Timing Diagram (RxSERCLK as an Output) 259

Figure 116.: Framer System Receive Timing Diagram (RxSERCLK as an Input) 260

Figure 117.: Framer System Transmit Overhead Timing Diagram 260

Figure 118.: Framer System Receive Overhead Timing Diagram (RxSERCLK as an Output) 261

Figure 119.: Framer System Receive Overhead Timing Diagram (RxSERCLK as an Input) 261

Figure 120.: ITU G.703 Pulse Template 265

Figure 121.: DSX-1 Pulse Template (normalized amplitude) 266

LIST OF TABLES

Table 1:: List by Pin Number	4
Table 2:: Selecting the Microprocessor Interface Mode	18
Table 3:: XRT86L30 Microprocessor Interface Signals that exhibit constant roles in both Intel and Motorola Modes	19
Table 4:: Intel mode: Microprocessor Interface Signals	19
Table 5:: Motorola Mode: Microprocessor Interface Signals	20
Table 6:: Intel Microprocessor Interface Timing Specifications	22
Table 7:: Intel Microprocessor Interface Timing Specifications	24
Table 8:: Motorola 68K Microprocessor Interface Timing Specifications	25
Table 9:: XRT86L30 Framer/LIU Register Map	27
Table 10:: Register Summary	28
Table 11:: Clock Select Register E1 Mode	34
Table 12:: Line Interface Control Register T1 Mode	35
Table 13:: General Purpose Input/Output 0 Control Register	35
Table 14:: Framing Select Register-E1 Mode	36
Table 15:: Framing Select Register-T1 Mode	37
Table 16:: Alarm Generation Register - E1 Mode	38
Table 17:: Alarm Generation Register -T1 Mode	39
Table 18:: Synchronization MUX Register - E1 Mode	41
Table 19:: Synchronization MUX Register - T1 Mode	42
Table 20:: Transmit Signaling and Data Link Select Register - E1 Mode	43
Table 21:: Transmit Signaling and Data Link Select Register - T1 Mode	44
Table 22:: Framing Control Register E1 Mode	45
Table 23:: Framing Control Register T1 Mode	46
Table 24:: Receive Signaling & Data Link Select Register - E1 Mode	47
Table 25:: Receive Signaling & Data Link Select Register (RS&DLSR) T1 Mode	48
Table 26:: Signaling Change Register 0 - T1 Mode	49
Table 27:: Signaling Change Register 1	49
Table 28:: Signaling Change Register 2	50
Table 29:: Signaling Change Register 3	50
Table 30:: Receive National Bits Register	50
Table 31:: Receive Extra Bits Register	51
Table 32:: Data Link Control Register	52
Table 33:: Transmit Data Link Byte Count Register	53
Table 34:: Receive Data Link Byte Count Register	54
Table 35:: Slip Buffer Control Register	54
Table 36:: FIFO Latency Register	55
Table 37:: DMA 0 (Write) Configuration Register	55
Table 38:: DMA 1 (Read) Configuration Register	56
Table 39:: Interrupt Control Register	57
Table 40:: LAPD Select Register	57
Table 41:: Customer Installation Alarm Generation Register	58
Table 42:: Performance Report Control Register	58
Table 43:: Gapped Clock Control Register	59
Table 44:: Gapped Clock Control Register	59
Table 45:: Transmit Interface Control Register - E1 Mode	60
Table 46:: Transmit Interface Control Register - T1 Mode	61
Table 47:: Receive Interface Control Register (RICR) - E1 Mode	63
Table 48:: Receive Interface Control Register (RICR) - T1 Mode	64
Table 49:: DS1 Test Register	65
Table 50:: Loopback Code Control Register	66
Table 51:: Transmit Loopback Coder Register	67
Table 52:: Receive Loopback Activation Code Register	67
Table 53:: Receive Loopback Deactivation Code Register	67
Table 54:: Transmit Sa Select Register	68
Table 55:: Transmit Sa Auto Control Register 1	68
Table 56:: Conditions on Receive side When TSACR1 bits Are enabled	69
Table 57:: Transmit Sa Auto Control Register 2	69
Table 58:: Conditions on Receive side When TSACR1 bits enabled	70

SINGLE T1/E1/J1 FRAMER/LIU COMBO

Table 59:: Transmit Sa4 Register	70
Table 60:: Transmit Sa5 Register	71
Table 61:: Transmit Sa6 Register	71
Table 62:: Transmit Sa7 Register	71
Table 63:: Transmit Sa8 Register	71
Table 64:: Receive Sa4 Register	72
Table 65:: Receive Sa5 Register	72
Table 66:: Receive Sa6 Register	72
Table 67:: Receive Sa7 Register	72
Table 68:: Receive Sa8 Register	73
Table 69:: Data Link Control Register	73
Table 70:: Transmit Data Link Byte Count Register	74
Table 71:: Receive Data Link Byte Count Register	75
Table 72:: Data Link Control Register	76
Table 73:: Transmit Data Link Byte Count Register	77
Table 74:: Receive Data Link Byte Count Register	78
Table 75:: Device ID Register	78
Table 76:: Revision ID Register	78
Table 77:: Transmit Channel Control Register 0 to 31 E1 Mode	78
Table 78:: Transmit Channel Control Register 0 to 31 T1 Mode	79
Table 79:: Transmit User Code Register 0 to 31	79
Table 80:: Transmit Signaling Control Register x - E1 Mode	79
Table 81:: Transmit Signaling Control Register x - T1 Mode	80
Table 82:: Receive Channel Control Register x (RCCR 0-31) - E1 Mode	80
Table 83:: Receive Channel Control Register x (RCCR 0-23) - T1 Mode	81
Table 84:: Receive User Code Register x (RUCR 0-31)	82
Table 85:: Receive Signaling Control Register x (RSCR) (0-31)	83
Table 86:: Receive Substitution Signaling Register (RSSR) E1 Mode	83
Table 87:: Receive Substitution Signaling Register (RSSR) T1 Mode	84
Table 88:: Receive Signaling Array Register 0 to 31	84
Table 89:: LAPD Buffer 0 Control Register	84
Table 91:: PMON T1/E1 Receive Line Code (bipolar) Violation Counter	85
Table 92:: PMON T1/E1 Receive Line Code (bipolar) Violation Counter	85
Table 90:: LAPD Buffer 1 Control Register	85
Table 93:: PMON T1/E1 Receive Framing Alignment Bit Error Counter	86
Table 94:: PMON T1/E1 Receive Framing Alignment Bit Error Counter	86
Table 95:: PMON T1/E1 Receive Severely Errored Frame Counter	86
Table 96:: PMON T1/E1 Receive CRC-4 Block Error Counter - MSB	87
Table 97:: PMON T1/E1 Receive CRC-4 Block Error Counter - LSB	87
Table 98:: PMON T1/E1 Receive Far-End BLock Error Counter - MSB	88
Table 99:: PMON T1/E1 Receive Far End Block Error Counter	88
Table 100:: PMON T1/E1 Receive Slip Counter	88
Table 101:: PMON T1/E1 Receive Loss of Frame Counter	89
Table 102:: PMON T1/E1 Receive Change of Frame Alignment Counter	89
Table 103:: PMON LAPD T1/E1 Frame Check Sequence Error Counter 1	89
Table 104:: T1/E1 PRBS Bit Error Counter MSB	90
Table 105:: T1/E1 PRBS Bit Error Counter LSB	90
Table 106:: T1/E1 Transmit Slip Counter	90
Table 107:: T1/E1 Excessive Zero Violation Counter MSB	91
Table 108:: T1/E1 Excessive Zero Violation Counter LSB	91
Table 109:: T1/E1 Frame Check Sequence Error Counter 2	91
Table 110:: T1/E1 Frame Check Sequence Error Counter 3	92
Table 111:: Block Interrupt Status Register	92
Table 112:: Block Interrupt Enable Register	93
Table 113:: Alarm & Error Interrupt Status Register	94
Table 114:: Alarm & Error Interrupt Enable Register - E1 Mode	95
Table 115:: Alarm & Error Interrupt Enable Register -T1 Mode	96
Table 116:: Framer Interrupt Status Register E1 Mode	97
Table 117:: Framer Interrupt Status Register T1 Mode	98
Table 118:: Framer Interrupt Enable Register E1 Mode	99

Table 119:: Framer Interrupt Enable Register T1 Mode	100
Table 120:: Data Link Status Register 1	101
Table 121:: Data Link Interrupt Enable Register 1	102
Table 122:: Slip Buffer Interrupt Status Register (SBISR)	103
Table 123:: Slip Buffer Interrupt Enable Register (SBIER)	104
Table 124:: Receive Loopback Code Interrupt and Status Register (RLCISR)	104
Table 125:: Receive Loopback Code Interrupt Enable Register (RLCIER)	105
Table 126:: Receive SA Interrupt Register (RSAIR)	105
Table 127:: Receive SA Interrupt Enable Register (RSAIER)	106
Table 128:: Excessive Zero Status Register	106
Table 129:: Excessive Zero Enable Register	107
Table 130:: SS7 Status Register for LAPD1	107
Table 131:: SS7 Enable Register for LAPD1	107
Table 132:: Data Link Status Register 2	107
Table 133:: Data Link Interrupt Enable Register 2	109
Table 134:: SS7 Status Register for LAPD2	110
Table 135:: SS7 Enable Register for LAPD2	110
Table 136:: Data Link Status Register 3	110
Table 137:: Data Link Interrupt Enable Register 3	112
Table 138:: SS7 Status Register for LAPD3	113
Table 139:: SS7 Enable Register for LAPD3	113
Table 140:: Customer Installation Alarm Status Register	113
Table 141:: Customer Installation Alarm Status Register	114
Table 142:: Microprocessor Register #556 Bit Description	115
Table 143:: Equalizer Control and Transmit Line Build Out	115
Table 144:: Microprocessor Register #557 Bit Description	117
Table 145:: Microprocessor Register #558 Bit Description	119
Table 146:: Microprocessor Register #559 Bit Description	121
Table 147:: Microprocessor Register #560 Bit Description	122
Table 148:: Microprocessor Register #561 Bit Description	123
Table 149:: Microprocessor Register #562 Bit Description	125
Table 150:: Microprocessor Register #563 Bit Description	125
Table 151:: Microprocessor Register #564 Bit Description	126
Table 152:: Microprocessor Register #565 Bit Description	126
Table 153:: Microprocessor Register #566 Bit Description	127
Table 154:: Microprocessor Register #567 Bit Description	127
Table 155:: Microprocessor Register #568 Bit Description	128
Table 156:: Microprocessor Register #569 Bit Description	128
Table 157:: Microprocessor Register #570 Bit Description	129
Table 158:: Microprocessor Register #571 Bit Description	129
Table 159:: Microprocessor Register #700 Bit Description - Global Register 0	130
Table 160:: Microprocessor Register #701, Bit Description - Global Register 1	130
Table 161:: Microprocessor Register #702, Bit Description - Global Register 2	131
Table 162:: Microprocessor Register #703, Bit Description - Global Register 3	131
Table 163:: Microprocessor Register #704, Bit Description - Global Register 4	132
Table 164:: List of the Possible Conditions that can Generate Interrupts, in each Framers	133
Table 165:: Address of the Block Interrupt Status Registers	134
Table 166:: Block Interrupt Status Register	134
Table 167:: Block Interrupt Enable Register	136
Table 168:: Interrupt Control Register	137
Table 169:: Framing Format for PMON Status Inserted within LAPD by Initiating APR	163
Table 170:: Random Bit Sequence Polynomials	180
Table 171:: Short Haul Line Build Out	181
Table 172:: Selecting the Internal Impedance	184
Table 173:: Selecting the Value of the External Fixed Resistor	184
Table 174:: The mapping of T1 frame into E1 framing format	206
Table 175:: Bit Format of Timeslot 0 octet within a FAS E1 Frame	244
Table 176:: Bit Format of Timeslot 0 octet within a Non-FAS E1 Frame	245
Table 177:: Bit Format of all Timeslot 0 octets within a CRC Multi-frame	246
Table 178:: Superframe Format	252

SINGLE T1/E1/J1 FRAMER/LIU COMBO

<i>Table 179:: Extended Superframe Format</i>	254
<i>Table 180:: Non-Signaling Framing Format</i>	255
<i>Table 181:: SLC®96 Fs Bit Contents</i>	256
<i>Table 182:: XRT86L30 Power Consumption</i>	257
<i>Table 183:: E1 Receiver Electrical Characteristics</i>	262
<i>Table 184:: T1 Receiver Electrical Characteristics</i>	263
<i>Table 185:: E1 Transmit Return Loss Requirement</i>	263
<i>Table 186:: E1 Transmitter Electrical Characteristics</i>	264
<i>Table 187:: T1 Transmitter Electrical Characteristics</i>	264
<i>Table 188:: Transmit Pulse Mask Specification</i>	265
<i>Table 189:: DSX1 Interface Isolated pulse mask and corner points</i>	266
<i>Table 190:: AC Electrical Characteristics</i>	266

1.0 PIN LIST
TABLE 1: LIST BY PIN NUMBER

PIN	PIN NAME
1	LOP
2	NC
3	NC
4	DVDD
5	DGND
6	TRING
7	TVDD
8	TTIP
9	TGND
10	JTAG_RING
11	JTAG_TIP
12	RGND
13	RRING
14	RTIP
15	RVDD
16	AVDD
17	AGND
18	SENSE
19	ANALOG
20	VDDPLL
21	VDDPLL
22	PLLGND
23	PLLGND
24	MCLKIN
25	MCLKnOUT
26	RxOH
27	RxCHN_4
28	RxCHN_3
29	DGND
30	RxCASync
31	RxOHCLK

PIN	PIN NAME
32	RxCHN_2
33	RxSYNC
34	NC
35	NC
36	RxCHN_1
37	DVDD
38	RxCHCLK
39	RxCRCsync
40	RxCHN_0
41	DVDD
42	RxSERCLK
43	RxLOS
44	RxSER
45	TxCHN_4
46	TxCHN_3
47	TxCHN_2
48	DGND
49	TxCHCLK
50	TxCHN_1
51	TxOH
52	DVDD
53	TxCHN_0
54	TxSERCLK
55	TxSER
56	DVDD
57	TxOHCLK
58	TxMSync
59	TxSYNC
60	DGND
61	REQ1
62	ACK0
63	DVDD
64	REQ0

PIN	PIN NAME
65	ACK1
66	NC
67	NC
68	PCLK
69	DATA0
70	DATA1
71	RD
72	DGND
73	DBEN
74	RDY
75	ADDR0
76	ADDR1
77	ADDR2
78	DVDD
79	ADDR3
80	ADDR4
81	ADDR5
82	ADDR6
83	DGND
84	ADDR7
85	RESET
86	OSCCLK
87	DGND
88	8Ksync
89	ADDR8
90	DATA2
91	DATA3
92	DVDD
93	ALE
94	ADDR9
95	ADDR10
96	INT
97	ADDR11

PIN	PIN NAME
98	NC
99	NC
100	BLAST
101	DATA4
102	DGND
103	DATA5
104	DATA6
105	DVDD
106	DATA7
107	WR
108	CS
109	DGND
110	DGND
111	TCK
112	TRST
113	TDI
114	TMS
115	TDO
116	GPIO1
117	GPIO0
118	GPIO2
119	GPIO3
120	aTEST
121	TEST
122	8KEXTOSC
123	fADDR
124	iADDR
125	PTYPE2
126	PTYPE1
127	PTYPE0
128	TxON

2.0 PIN DESCRIPTIONS

TRANSMIT SERIAL DATA INPUT

SIGNAL NAME	PIN #	TYPE	DESCRIPTION
TxSER	55	I	<p>Transmit Serial Data Input</p> <p>This input pin along with TxSERCLK functions as the Transmit Serial input port to the framer block.</p> <p>DS1 Mode</p> <p>Any payload data applied to this pin will be inserted into a DS1 frame and output onto the T1 line. If the framer is configured accordingly, the framing alignment bits, facility data link bits, and the CRC-6 bits can be inserted to this input pin. The signal applied to this input pin can be latched to the Transmit Payload Data Input Interface on either the rising edge or the falling edge of TxSERCLK.</p> <p>E1 Mode</p> <p>Any payload data applied to this pin will be inserted into an E1 frame and output onto the E1 line. All data intended to be transported via Time Slots 1 through 15 and Time slots 17 through 31 must be applied to this input pin. If the framer is configured accordingly, data intended for Time Slots 0 and 16 can also be applied to this input pin.</p> <p>Framer Bypass Mode</p> <p>In framer bypass mode, TxSER is used for the positive digital input pin to the LIU.</p>
TxSERCLK	54	I/O	<p>Transmit Serial Clock Input/Output</p> <p>This clock signal is used by the Transmit payload data Input Interface to latch the contents of the TxSER signal into the framer. Data that is applied at the TxSER input can be latched on either the rising edge or the falling edge of TxSERCLK.</p> <p>DS1/E1 Standard Rate Mode (1.544Mhz/2.048MHz)</p> <p>If the Transmit Section of the framer has been configured to use TxSERCLK as the timing source, then this signal will be an input. If the recovered line clock or the MCLKIN input pin is used as the timing source for the transmitter, then TxSERCLK will be an output.</p> <p>DS1/E1 High-Speed Backplane Interface</p> <p>In High-Speed backplane applications, TxSERCLK is used as the timing source for the transmit line rate.</p> <p>Framer Bypass Mode</p> <p>In framer bypass mode, TxSERCLK is used for the transmit clock to the LIU.</p>
TxSYNC	59	I/O	<p>Transmit Single Frame Sync Pulse Input/Output</p> <p>This pin is configured to be an input if TxSERCLK is used as the timing reference for the transmitter. This pin is configured as an output if the recovered line clock or the MCLKIN input pin is used as the timing reference for the transmitter.</p> <p>DS1/E1 (TxSYNC as an Input)</p> <p>TxSYNC must pulse "High" for one period of TxSERCLK when the transmit payload data Input Interface is processing the first bit of an outbound DS1/E1 frame.</p> <p>NOTE: It is imperative that the TxSYNC input signal be synchronized with the TxSERCLK input signal.</p> <p>DS1/E1 (TxSYNC as an output)</p> <p>TxSYNC will pulse "High" for one period of TxSERCLK when the transmit payload data Input Interface is processing the first bit of an outbound DS1/E1 frame.</p> <p>Framer Bypass Mode</p> <p>In framer bypass mode, TxSYNC is used for the negative digital input pin to the LIU.</p>

TRANSMIT SERIAL DATA INPUT

SIGNAL NAME	PIN #	TYPE	DESCRIPTION
TxMSYNC/ TxINCLK	58	I/O	<p>Multiframe Sync Pulse/Transmit Input Clock</p> <p>This pin is a multiplexed I/O pin. When the device is configured to be in standard rate mode, this signal indicates the boundary of an outbound multi-frame. When the device is configured to be in High-Speed mode, this pin functions as an input clock signal for the high-speed Transmit back-plane interface.</p> <p>DS1/E1 Standard Rate Mode (TxMSYNC as an Input)</p> <p>This pin is configured to be an input if TxSERCLK is used as the timing reference for the transmitter. TxMSYNC must pulse "High" for one period of TxSERCLK when the transmit payload data Input Interface is processing the first bit of an outbound DS1/E1 multi frame.</p> <p>NOTE: <i>It is imperative that the TxMSYNC input signal be synchronized with the TxSERCLK input signal.</i></p> <p>DS1/E1 Standard Rate Mode (TxMSYNC as an output)</p> <p>This pin is configured as an output if the recovered line clock or the MCLKIN input pin is used as the timing reference for the transmitter. TxMSYNC will pulse "High" for one period of TxSERCLK when the transmit payload data Input Interface is processing the first bit of an outbound DS1/E1 frame.</p> <p>DS1/E1 Non-Multiplexed High-Speed Backplane Interface</p> <p>In the non-multiplexed high-speed interface mode, this pin is used as the timing source for the high-speed data applied to TxSER. The non-multiplexed modes supported are MVIP 2.048MHz, 4.096MHz, and 8.192MHz.</p> <p>NOTE: <i>For DS1 mode, the DS-0 data is mapped into an E1 frame by ignoring every fourth time slot (don't care).</i></p> <p>DS1/E1 Multiplexed High-Speed Backplane Interface</p> <p>In the multiplexed high-speed interface mode, this pin is used as the timing source for the high-speed data applied to TxSER. The multiplexed modes supported are 12.352MHz (DS1 only), 16.384MHz, 16.384MHz HMVIP, and 16.384MHz H.100.</p> <p>For DS1 mode in 16.384MHz rate, the DS-0 data is mapped into an E1 frame by ignoring every fourth time slot (don't care).</p>
TxCHCLK	49	O	<p>Transmit Channel Clock Output Signal</p> <p>This pin indicates the boundary of each time slot of an outbound DS1/E1 frame.</p> <p>DS1/E1 Mode</p> <p>Each of these output pins is 192kHz/256kHz clock for DS1/E1 respectively which pulses "High" whenever the Transmit Payload Data Input Interface block accepts the LSB of each of the 24/32 time slots. The Terminal Equipment can use this clock signal to sample the TxCHN0 through TxCHN4 time slot identifier pins.</p> <p>DS1/E1 Fractional Interface Clock</p> <p>In the fractional interface mode, TxCHCLK can be configured to function as one of the following: The pin will output a gapped fractional clock that can be used by terminal equipment input fractional payload data using the falling edge of the clock. Otherwise the fractional payload data is clocked into the chip using the un-gapped TxSERCLK pin.</p>

TRANSMIT SERIAL DATA INPUT

SIGNAL NAME	PIN #	TYPE	DESCRIPTION
TxCHN_0/ TxSig	53	O	<p>Transmit Time Slot Octet Identifier Output-Bit 0</p> <p>These output signals (TxCHN4_n through TxCHN0_n) reflect the five-bit binary value of the number of the current time slot being accepted and processed by the transmit payload data input Interface block. Terminal Equipment can use TxCHCLK to sample the five output pins of each channel in order to identify the time slot being processed.</p> <p>Transmit Serial Signaling Bus Input</p> <p>These pins can be used to input robbed-bit signaling data within an outbound DS1 frame or to input Channel Associated Signaling (CAS) bits within an outbound E1 frame.</p>
TxCHN_1/ TxFrTD	50	I/O	<p>Transmit Time Slot Octet Identifier Output-Bit 1</p> <p>These output signals (TxCHN4_n through TxCHN0_n) reflect the five-bit binary value of the number of Time Slot being accepted and processed by the transmit payload data input Interface. Terminal Equipment can use TxCHCLK to sample the five output pins of each channel in order to identify the time slot being processed.</p> <p>Transmit Serial Fractional DS1/E1 Input</p> <p>These pins can be used to input fractional DS1/E1 payload data within an outbound DS1/E1 frame. In this mode, terminal equipment will use either TxCHCLK or TxSERCLK to sample fractional DS1/E1 payload data.</p>
TxCHN_2/ Tx12MHz	47	O	<p>Transmit Time Slot Octet Identifier Output-Bit 2</p> <p>These output signals (TxCHN4_n through TxCHN0_n) reflect the five-bit binary value of the number of Time Slot being accepted and processed by the transmit payload data input Interface block. Terminal Equipment can use TxCHCLK to sample the five output pins of each channel in order to identify the time slot being processed. If TxCHN1_n is configured as TxFrTD_n to input fractional DS1/E1 payload data, the TxCHN2_n pin will serially output the five-bit binary value of the number of the Time Slot being accepted and processed.</p> <p>Transmit 12.352MHz Clock Output</p> <p>These pins can be used to output 12.352MHz/16.384MHz clock derived from the MCLKIN input pin.</p>
TxCHN_3/ TxOHSync	46	O	<p>Transmit Time Slot Octet Identifier Output-Bit 3:</p> <p>These output signals (TxCHN4_n through TxCHN0_n) reflect the five-bit binary value of the number of Time Slot being accepted and processed by the transmit payload data input Interface block. Terminal Equipment can use TxCHCLK to sample the five output pins of each channel in order to identify the time slot being processed.</p> <p>Transmit Overhead Synchronization Pulse</p> <p>These pins can be used to output an Overhead Synchronization Pulse that indicates the first bit of each multi-frame.</p>
TxCHN_4	45	O	<p>Transmit Time Slot Octet Identifier Output-Bit 4:</p> <p>These output signals (TxCHN4_n through TxCHN0_n) reflect the five-bit binary value of the number of Time Slot being accepted and processed by the transmit payload data input Interface block. Terminal Equipment can use TxCHCLK to sample the five output pins of each channel in order to identify the time slot being processed.</p>

OVERHEAD INTERFACE

SIGNAL NAME	PIN #	TYPE	DESCRIPTION
TxOH	51	I	<p>Transmit Overhead Input</p> <p>This input pin, along with TxOHCLK functions as the Transmit Overhead input port.</p> <p>DS1 Mode</p> <p>This input pin will become active if the Transmit Section has been configured to use this input as the source for the Facility Data Link bits in ESF framing mode, Fs bits in the SLC96 and N framing mode, and R bit in T1DM mode. The data that is input into this pin will be inserted into the Data Link Bits within the out-bound DS1 frames at the falling edge of TxSERCLK.</p> <p>NOTE: <i>This input pin will be disabled if the framer is using the Transmit HDLC Controller, or the TxSER input as the source for the Data Link Bits.</i></p> <p>E1 Mode</p> <p>This input pin will become active if the Transmit Section has been configured to use this input as the source for the Data Link bits. The data that is input into this pin will be inserted into the Sa4 through Sa8 bits (the National Bits) within the outbound non-FAS E1 frames.</p> <p>NOTE: <i>This input pin will be disabled if the framer is using the Transmit HDLC Controller, or the TxSER input as the source for the Data Link Bits.</i></p>
TxOHCLK	57	O	<p>Transmit OH Serial Clock Output Signal</p> <p>This output clock signal functions as a demand clock signal for the transmit overhead data input interface block.</p> <p>DS1/E1 Mode</p> <p>If the TxOH pins have been configured to be the source for the Facility Data Link bits, then the framer will provide a clock edge for each Data Link Bit. The Data Link Equipment can provide data to TxOH on the rising edge of TxOHCLK. The framer will latch the data on the falling edge of this clock signal.</p>
RxOH	26	O	<p>Receive Overhead Output</p> <p>This pin, along with RxOHCLK functions as the Receive Overhead Output Interface.</p> <p>DS1 Mode</p> <p>This pin unconditionally outputs the contents of the Facility Data Link Bit in ESF framing mode, Fs bit in the SLC96 and N framing mode, and R bit in T1DM framing mode.</p> <p>NOTE: <i>This output pin is active even if the Receive HDLC Controller is active.</i></p> <p>E1 mode</p> <p>This pin unconditionally outputs the contents of the National Bits (Sa4 through Sa8). If the framer has been configured to interpret the National bits of the incoming E1 frames as carrying Data Link information, then the Receive Overhead Output Interface will provide a clock pulse on RxOHCLK for each Sa bit carrying Data Link information.</p> <p>NOTE: <i>This output pin is active even if the Receive HDLC Controller is active.</i></p>
RxOHCLK	31	O	<p>Receive OH Serial Clock Output Signal</p> <p>This pin, along with RxOH functions as the Receive Overhead Output Interface.</p> <p>DS1/E1 Mode</p> <p>This pin outputs a clock edge corresponding to each Facility Data Link Bit which carries Data Link information. The Data Link Equipment can sample data from RxOH on the rising edge of RxOHCLK. The framer will update the data on the falling edge of this clock signal.</p>

RECEIVE SERIAL DATA OUTPUT

SIGNAL NAME	PIN #	TYPE	DESCRIPTION
RxSYNC	33	I/O	<p>Receive Single Frame Sync Pulse Input/Output</p> <p>This pin is configured to be an input if the slip buffer is enabled in the receive path. Otherwise, this pin is an output signal.</p> <p>DS1/E1 (RxSYNC as an Input)</p> <p>RxSYNC must pulse "High" for one period of RxSERCLK and repeat every 125μS. The framer will output the first bit of an inbound DS1/E1 frame during the provided RxSYNC pulse.</p> <p>NOTE: <i>It is imperative that the RxSYNC input signal be synchronized with RxSERCLK.</i></p> <p>DS1/E1 (TxSYNC as an output)</p> <p>RxSYNC will pulse "High" for one period of RxSERCLK when the receive payload data Input Interface is processing the first bit of an inbound DS1/E1 frame.</p> <p>Framer Bypass Mode</p> <p>In framer bypass mode, RxSYNC is used for the negative digital output pin to the LIU.</p>
RxCRCSYNC	39	O	<p>Multiframe Sync Pulse Output</p> <p>This DS1 only signal will pulse "High" for one period of RxSERCLK the instant that the Receive payload data Interface is processing the first bit of a DS1 Multi-frame.</p>
RxCASync	30	O	<p>Receive CAS Multiframe Sync Output Signal</p> <p>This E1 only signal will pulse "High" for one period of RxSERCLK the instant that the Receive payload data Interface is processing the first bit of an E1 CAS Multi-frame.</p>
RxSERCLK	42	I/O	<p>Receive Serial Clock Signal</p> <p>This clock signal is used by the Receive payload data Output Interface to latch/update the contents of RxSER. The output data on RxSER can be updated on either the rising edge or the falling edge of RxSERCLK. This pin is configured to be an input if the slip buffer is enabled in the receive path. Otherwise, this pin is an output signal.</p> <p>DS1/E1 Non-Multiplexed High-Speed Backplane Interface (Input Only)</p> <p>In the non-multiplexed high-speed interface mode, this pin is used as the timing source for the high-speed output data to RxSER. The non-multiplexed modes supported are MVIP 2.048MHz, 4.096MHz, and 8.192MHz.</p> <p>NOTE: <i>For DS1 mode, the DS-0 data is mapped into an E1 frame by ignoring every fourth time slot (don't care).</i></p> <p>DS1/E1 Multiplexed High-Speed Backplane Interface (Input Only)</p> <p>In the multiplexed high-speed interface mode, this pin is used as the timing source for the high-speed output data to RxSER. The multiplexed modes supported are 12.352MHz (DS1 only), 16.384MHz, 16.384MHz H.MVIP, and 16.384MHz H.100.</p> <p>For DS1 mode in 16.384MHz rate, the DS-0 data is mapped into an E1 frame by ignoring every fourth time slot (don't care).</p> <p>Framer Bypass Mode:</p> <p>In framer bypass mode, RxSERCLK is used for the receive clock to the LIU.</p>

RECEIVE SERIAL DATA OUTPUT

SIGNAL NAME	PIN #	TYPE	DESCRIPTION
RxSER	44	O	<p>Receive Serial Data Output</p> <p>This output pin along with RxSERCLK functions as the Receive Serial Output. DS1/E1 mode</p> <p>Any incoming T1/E1 line data that is received from the line will be decoded and output via this pin. The framer can use either the rising edge or the falling edge of RxSERCLK to update the received T1/E1 payload data.</p> <p>Framer Bypass Mode:</p> <p>In framer bypass mode, RxSER is used for the positive digital output pin to the LIU.</p>
RxCHN_0/ RxSig	40	O	<p>Receive Time Slot Octet Identifier Output-Bit 0</p> <p>These output signals (RxCHN4_n through RxCHN0_n) reflect the five-bit binary value of the number of Time Slot being received and output to the Terminal Equipment via the Receive Payload Data Output Interface. The Terminal Equipment can use RxCHCLK to sample these five output pins in order to identify the time slot being processed.</p> <p>Receive Serial Signaling Output</p> <p>These pins can be used to output robbed-bit signaling (DS1) or CAS signaling (E1) extracted from an incoming DS1/E1 frame.</p>
RxCHN_1/ RxFrTD	36	O	<p>Receive Time Slot Octet Identifier Output-Bit 1</p> <p>These output signals (RxCHN4_n through RxCHN0_n) reflect the five-bit binary value of the number of Time Slot being received and output to the Terminal Equipment via the Receive Payload Data Output Interface. The Terminal Equipment can use RxCHCLK to sample these five output pins in order to identify the time slot being processed.</p> <p>Receive Serial Fractional DS1/E1 Output</p> <p>These pins can be used to output fractional DS1/E1 payload data within an inbound DS1/E1 frame. In this mode, terminal equipment will use either RxCHCLK or RxSERCLK to clock out fractional DS1/E1 payload data.</p>
RxCHN_2/ RxCHN	32	O	<p>Receive Time Slot Octet Identifier Output-Bit 2</p> <p>These output signals (RxCHN4_n through RxCHN0_n) reflect the five-bit binary value of the number of Time Slot being received and output to the Terminal Equipment via the Receive Payload Data Output Interface. The Terminal Equipment can use RxCHCLK to sample these five output pins in order to identify the time slot being processed.</p> <p>Receive Time Slot Identifier Serial Output</p> <p>If RxCHN1 is configured as RxFrTD to output fractional DS1/E1 payload data, then these pins serially output the five-bit binary value of the number of the Time Slot being accepted and processed by the Transmit Payload Data Input Interface.</p>
RxCHN_3/ Rx8KHZ	28	O	<p>Receive Time Slot Octet Identifier Output-Bit 3</p> <p>These output signals (RxCHN4_n through RxCHN0_n) reflect the five-bit binary value of the number of Time Slot being received and output to the Terminal Equipment via the Receive Payload Data Output Interface. The Terminal Equipment can use RxCHCLK to sample these five output pins in order to identify the time slot being processed.</p> <p>Receive 8KHz Clock Output</p> <p>These pins can output a reference 8KHz clock signal if configured accordingly.</p>

RECEIVE SERIAL DATA OUTPUT

SIGNAL NAME	PIN #	TYPE	DESCRIPTION
RxCHN_4/ RxSCLK	27	O	<p>Receive Time Slot Octet Identifier Output-Bit 4</p> <p>These output signals (RxCHN4_n through RxCHN0_n) reflect the five-bit binary value of the number of Time Slot being received and output to the Terminal Equipment via the Receive Payload Data Output Interface. The Terminal Equipment can use RxCHCLK to sample these five output pins in order to identify the time slot being processed.</p> <p>Receive Recovered Line Clock Output</p> <p>These pins output the recovered T1/E1 line clock (1.544MHz and 2.048MHz) for each channel in the High-Speed modes of operation.</p>
RxCHCLK	38	O	<p>Receive Channel Clock Output</p> <p>This pin indicates the boundary of each time slot of an outbound DS1/E1 frame. DS1/E1 Mode</p> <p>Each of these output pins is 192kHz/256kHz clock for DS1/E1 respectively which pulses "High" whenever the Receive Payload Data Input Interface block outputs the LSB of each of the 24/32 time slots. The Terminal Equipment can use this clock signal to sample the RxCHN0 through RxCHN4 time slot identifier pins.</p> <p>DS1/E1 Fractional Interface Clock</p> <p>In the fractional interface mode, RxCHCLK can be configured to function as one of the following: The pin will output a gapped fractional clock that can be used by terminal equipment to output fractional payload data using the rising edge of the clock. Otherwise, the fractional payload data is clocked out of the chip using the un-gapped RxSERCLK pin.</p>

RECEIVE LINE INTERFACE

SIGNAL NAME	PIN #	TYPE	DESCRIPTION
RTIP	14	I	<p>Receive Positive Analog Input</p> <p>RTIP is the positive differential input from the line interface. Along with the RRING signal, these pins should be coupled to a 1:1 transformer for proper operation. The center tap of the receive transformer should have a bypass capacitor of 0.1µF to ground (Chip Side).</p>
RRING	13	I	<p>Receive Negative Analog Input</p> <p>RRING is the negative differential input from the line interface. Along with the RTIP signal, these pins should be coupled to a 1:1 transformer for proper operation. The center tap of the receive transformer should have a bypass capacitor of 0.1µF to ground (Chip Side).</p>

RECEIVE LINE INTERFACE

SIGNAL NAME	PIN #	TYPE	DESCRIPTION
RxLOS	43	O	<p>Receive Loss of Signal Output Indicator</p> <p>This output pin will toggle "High" (declare LOS) if the Receive block associated with Channel N determines that an RLOS condition occurs according to G.775. Conversely, the XRT86L30 will "TRI-State" this pin anytime (and for the duration that) the Receive DS1/E1 Framer or LIU block is NOT declaring the LOS defect condition.</p> <p>NOTE: Since the XRT86L30 tri-states this output pin (anytime the channel is not declaring the LOS defect condition), the user MUST connect a "pull-down" resistor (ranging from 1K to 10K) to each RxLOS output pin, to pull this output pin to the logic "LOW" condition, whenever the Channel is NOT declaring the LOS defect condition.</p> <p>This pin is OR-ed with the LIU RLOS and the Framer RLOS bit. If either the LIU RLOS or the Framer RLOS bit pulses high, these RLOS pins will be set to "High".</p>

TRANSMIT LINE INTERFACE

SIGNAL NAME	PIN #	TYPE	DESCRIPTION
TTIP	8	O	<p>Transmit Positive Analog Output</p> <p>TTIP is the positive differential output to the line interface. Along with the TRING signal, these pins should be coupled to a 1:2 step up transformer for proper operation. This pin should have a series line capacitor of 0.68μF.</p>
TRING	6	O	<p>Transmit Negative Analog Output</p> <p>TRING is the negative differential output to the line interface. Along with the TTIP signal, these pins should be coupled to a 1:2 step up transformer for proper operation.</p>
TxON	128	I	<p>Transmitter On</p> <p>Upon power up, the transmit output (TTIP/TRING) is tri-stated. Turning the transmitter On or Off is selected by programming the appropriate register if this pin is pulled "High". If the TxON pin is pulled "Low", the transmitter is tri-stated.</p> <p>NOTE: Internally pulled "Low" with a 50kΩ resistor.</p>

TIMING INTERFACE

SIGNAL NAME	PIN #	TYPE	DESCRIPTION
MCLKIN	24	I	<p>Master Clock Input:</p> <p>This pin is used to provide the timing reference for the internal master clock of the device. The frequency of this clock is programmable from 8kHz to 16.384MHz in register 0x0FE9.</p>
MCLKnOUT	25	O	<p>LIU T1/E1 Output Clock Reference</p> <p>This output clock depends on the mode of operation. In T1 mode, this output pin is defaulted to 1.544MHz, but can be programmed to output 3.088MHz, 6.176MHz, or 12.352MHz in register 0x0FE4. In E1 mode, this output pin is defaulted to 2.048MHz, but can be programmed to 4.096MHz, 8.192MHz, or 16.384MHz in register 0x0FE4.</p>

TIMING INTERFACE

SIGNAL NAME	PIN #	TYPE	DESCRIPTION
OSCCLK	86	O	Framer T1/E1 Output Clock Reference This output clock depends on the mode of operation. In T1 mode, this output pin is defaulted to 1.544MHz, but can be programmed to output 49.408MHz in register 0x011E. In E1 mode, this output pin is defaulted to 2.048MHz, but can be programmed to 65.536MHz in register 0x011E.
8KSYNC	88	O	8kHz Clock Output Reference This pin is an output reference of 8kHz based on the MCLKIN input. Therefore, the duty cycle of this output is determined by the time period of the input clock reference.
8KEXTOSC	122	I	External Oscillator Select For normal operation, this pin should not be used, or pulled "Low". NOTE: This pin is internally pulled "Low" with a 50k Ω resistor.
ANALOG	19	O	Factory Test Mode Pin Note: For Internal Use Only
LOP	1	I	Loss of Power for E1 Only / Input Pin for Messaging

GPIO CONTROL

SIGNAL NAME	PIN #	TYPE	DESCRIPTION
GPIO_3	119	I/O	General Purpose Input/Output Pins The GPIO pins can be used as either inputs or outputs selected by register 0x0102. By default, these pins are inputs. To configure a GPIO pin to be an output, the register bit must be set to "1".
GPIO_2	118		
GPIO_1	116		
GPIO_0	117		

JTAG

SIGNAL NAME	PIN #	TYPE	DESCRIPTION
TCK	111	I	Test clock: Boundary Scan clock input. Note: This input pin should be pulled "Low" for normal operation
TMS	114	I	Test Mode Select: Boundary Scan Mode Select input. Note: This input pin should be pulled "Low" for normal operation
TDI	113	I	Test Data In: Boundary Scan Test data input Note: This input pin should be pulled "Low" for normal operation
TDO	115	O	Test Data Out: Boundary Scan Test data output
TRST	112	I	JTAG Test Reset Input
TEST	121	I	Factory Test Mode Pin Note: User should tie this pin to ground
aTEST	120	I	Factory Test Mode Pin Note: User should tie this pin to ground
SENSE	18	I	Factory Test Mode Pin Note: User should tie this pin to ground

JTAG

SIGNAL NAME	PIN #	TYPE	DESCRIPTION
JTAG_Ring	10	I	JTAG_Ring Test Pin
JTAG_Tip	11	I	JTAG_Tip Test Pin

MICROPROCESSOR INTERFACE

(Framer Channel Number indicated by)

SIGNAL NAME	PIN #	TYPE	DESCRIPTION
DATA0	69	I/O	Bidirectional Microprocessor Data Bus Data[7:0] is a bi-directional data bus used for read and write operations. NOTE: This bus is used as the bi-directional data port for storing and retrieving information through the DMA interface if enabled.
DATA1	70		
DATA2	90		
DATA3	91		
DATA4	101		
DATA5	103		
DATA6	104		
DATA7	106		
REQ0	64	O	DMA Cycle Request Output—DMA Controller 0 (Write): The Framer asserts this output pin (toggles it "Low") when at least one of the Transmit HDLC buffers are empty and can receive one more HDLC message. The Framer negates this output pin (toggles it "High") when the HDLC buffer can no longer receive another HDLC message. DMA Cycle Request Output—DMA Controller 1 (Read): The Framer asserts this output pin (toggles it "Low") when one of the Receive HDLC buffer contains a complete HDLC message that needs to be read by the μ C/ μ P. The Framer negates this output pin (toggles it High) when the Receive HDLC buffers are depleted.
REQ1	61		
INT	96	O	Interrupt Request Output: The Framer will assert this active "Low" output (toggles it "Low"), to the local μ P, anytime it requires interrupt service.
PCLK	68	I	Microprocessor Clock Input: This clock signal is the Microprocessor Interface System clock. This clock signal is used for synchronous/DMA data transfer. The maximum frequency of this clock signal is 33MHz.
iADDR	124	I	This Pin Must be Tied "Low" for Normal Operation.
fADDR	123	I	This Pin Must be Tied "High" for Normal Operation.

MICROPROCESSOR INTERFACE

(Framer Channel Number indicated by)

SIGNAL NAME	PIN #	TYPE	DESCRIPTION																
PTYPE0 PTYPE1 PTYPE2	127 126 125	I	<p>Microprocessor Type Input: These input pins permit the user to specify which type of Microprocessor/Micro-controller to be interfaced the Framer.</p> <table border="1" style="margin-left: auto; margin-right: auto;"> <thead> <tr> <th>μPType2</th> <th>μPType1</th> <th>μPType0</th> <th>MICROPROCESSOR TYPE</th> </tr> </thead> <tbody> <tr> <td>0</td> <td>0</td> <td>0</td> <td>68HC11, 8051, 80C188</td> </tr> <tr> <td>0</td> <td>0</td> <td>1</td> <td>MOTOROLA 68K</td> </tr> <tr> <td>1</td> <td>0</td> <td>1</td> <td>IBM POWER PC 403</td> </tr> </tbody> </table>	μ PType2	μ PType1	μ PType0	MICROPROCESSOR TYPE	0	0	0	68HC11, 8051, 80C188	0	0	1	MOTOROLA 68K	1	0	1	IBM POWER PC 403
μ PType2	μ PType1	μ PType0	MICROPROCESSOR TYPE																
0	0	0	68HC11, 8051, 80C188																
0	0	1	MOTOROLA 68K																
1	0	1	IBM POWER PC 403																
RDY	74	O	<p>Ready/Data Transfer Acknowledge Output: The exact behavior of this pin depends upon which Microprocessor the Framer is configured to interface to: Intel Type Microprocessors This output pin toggles "Low" when the Framer is ready to respond to the current PIO (Programmed I/O) or Burst Transaction. Motorola Type Microprocessors This output pin toggles "Low" when the Framer has completed the current bus cycle.</p>																
ADDR0 ADDR1 ADDR2 ADDR3 ADDR4 ADDR5 ADDR6 ADDR7 ADDR8 ADDR9 ADDR10 ADDR11	75 76 77 79 80 81 82 84 89 94 95 97	I	<p>Microprocessor Interface Address Bus Input ADDR[11:0] is a direct address bus for permitting access to internal registers for read and write operations.</p>																
DBEN	73	I	<p>Data Bus Enable Input pin. This Active-Low pin is used to enable the bi-directional databus. To disable the databus, this pin must be pulled "High".</p>																
ALE	93	I	Address Latch Enable Input_Address Strobe																

MICROPROCESSOR INTERFACE

(Framer Channel Number indicated by)

SIGNAL NAME	PIN #	TYPE	DESCRIPTION
CS	108	I	Microprocessor Interface—Chip Select Input: The Microprocessor/Microcontroller must assert this input pin (toggle it "Low") in order to exchange data with the Framer. Note: For the 68K MPU, this signal is generated by address decode and address strobe.
RD	71	I	Microprocessor Interface—Read Strobe Input: The exact behavior of this pin depends upon the type of Microprocessor/Microcontroller the Framer has been configured to interface to, as defined by the μ PTYPE[2:0] pins.
WR	107	I	Microprocessor Interface—Write Strobe Input The exact behavior of this pin depends upon the type of Microprocessor/Microcontroller the Framer has been configured to interface to, as defined by the μ PTYPE[2:0] pins.
ACK0	62	I	DMA Cycle Acknowledge Input—DMA Controller 0 (Write): The external DMA Controller will assert this input pin "Low" when the following two conditions are met: a. After the DMA Controller, within the Framer has asserted (toggled "Low"), the Req_0 output signal. b. When the external DMA Controller is ready to transfer data from external memory to the selected Transmit HDLC buffer. At this point, the DMA transfer between the external memory and the selected Transmit HDLC buffer may begin. After completion of the DMA cycle, the external DMA Controller will negate this input pin after the DMA Controller within the Framer has negated the Req_0 output pin. The external DMA Controller must do this in order to acknowledge the end of the DMA cycle.
ACK1	65	I	DMA Cycle Acknowledge Input—DMA Controller 1 (Read): The external DMA Controller asserts this input pin "Low" when the following two conditions are met: a. After the DMA Controller, within the Framer has asserted (toggled "Low"), the Req_1 output signal. b. When the external DMA Controller is ready to transfer data from the selected Receive HDLC buffer to external memory. At this point, the DMA transfer between the selected Receive HDLC buffer and the external memory may begin. After completion of the DMA cycle, the external DMA Controller will negate this input pin after the DMA Controller within the Framer has negated the Req_1 output pin. The external DMA Controller will do this in order to acknowledge the end of the DMA cycle.
BLAST	100	I	Last Cycle of Burst Indicator Input: The Microprocessor asserts this pin "Low" when it is performing its last read or write cycle, within a burst operation.
RESET	85	I	Hardware Reset Input Reset is an active low input. If this pin is pulled "Low" for more than 10 μ S, the device will be reset, and the internal registers will be reset to their default values.

POWER SUPPLY PINS

SIGNAL NAME	TYPE	DESCRIPTION
DVDD	PWR	Framer Block Power Supply 4, 37, 41, 52, 56, 63, 78, 92, 105
AVDD	PWR	Analog Power Supply for LIU Section 16
RVDD	PWR	Receiver Analog Power Supply for LIU Section 15
TVDD	PWR	Transmitter Analog Power Supply for LIU Section 7
VDDPLL	PWR	Analog Power Supply for PLL 20, 21

GROUND PINS

SIGNAL NAME	TYPE	DESCRIPTION
DGND	GND	Framer Block Ground 5, 29, 48, 60, 72, 83, 87, 102, 109, 110
AGND	GND	Analog Ground for LIU Section 17
RGND	GND	Receiver Analog Ground for LIU Section 12
TGND	GND	Transmitter Analog Ground for LIU Section 9
PLLGND	GND	Analog Ground for PLL 22, 23

NO CONNECT PINS

SIGNAL NAME	TYPE	DESCRIPTION
NC	NC	Not Connected 2, 3, 34, 35, 66, 67, 98, 99

3.0 MICROPROCESSOR INTERFACE BLOCK

The Microprocessor Interface section supports communication between the local microprocessor (μ P) and the Framer/LIU combo. The XRT86L30 supports an Intel asynchronous interface, Motorola 68K asynchronous, and a Motorola Power PC interface. The microprocessor interface is selected by the state of the PTYPE[2:0] input pins. Selecting the microprocessor interface is shown in **Table 2**.

TABLE 2: SELECTING THE MICROPROCESSOR INTERFACE MODE

PTYPE[2:0]	MICROPROCESSOR MODE
0h (000)	Intel 68HC11, 8051, 80C188 (Asynchronous)
1h (001)	Motorola 68K (Asynchronous)
7h (111)	Motorola MPC8260, MPC860 Power PC (Synchronous)

The XRT86L30 uses multipurpose pins to configure the device appropriately. The local μ P configures the Framer/LIU by writing data into specific addressable, on-chip Read/Write registers. The microprocessor interface provides the signals which are required for a general purpose microprocessor to read or write data into these registers. The microprocessor interface also supports polled and interrupt driven environments. A simplified block diagram of the microprocessor is shown in **Figure 2**.

FIGURE 2. SIMPLIFIED BLOCK DIAGRAM OF THE MICROPROCESSOR INTERFACE BLOCK

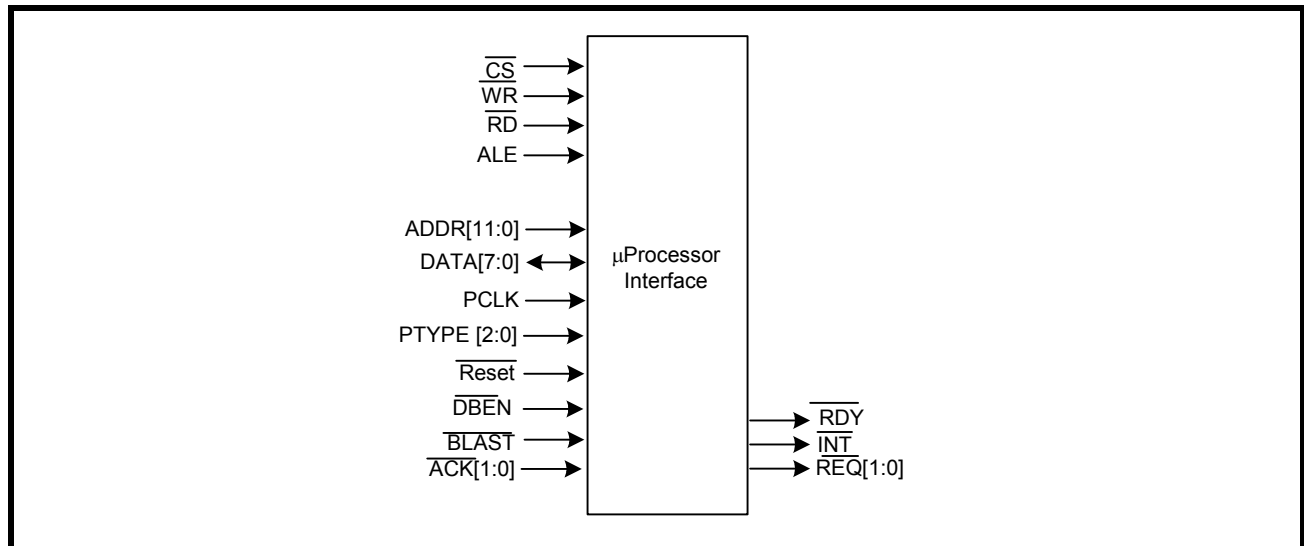

3.0.1 The Microprocessor Interface Block Signals

The XRT86L30 may be configured into different operating modes and have its performance monitored by software through a standard microprocessor using data, address and control signals. These interface signals are described below in **Table 3**, **Table 4**, and **Table 5**. The microprocessor interface can be configured to operate in Intel mode or Motorola mode. When the microprocessor interface is operating in Intel mode, some of the control signals function in a manner required by the Intel 80xx family of microprocessors. Likewise, when the microprocessor interface is operating in Motorola mode, then these control signals function in a manner as required by the Motorola Power PC family of microprocessors. (For using a Motorola 68K asynchronous processor, see **Figure 5** and **Table 8**) **Table 3** lists and describes those microprocessor interface signals whose role is constant across the two modes. **Table 4** describes the role of some of these signals when the microprocessor interface is operating in the Intel mode. Likewise, **Table 5** describes the role of these signals when the microprocessor interface is operating in the Motorola mode.

TABLE 3: XRT86L30 MICROPROCESSOR INTERFACE SIGNALS THAT EXHIBIT CONSTANT ROLES IN BOTH INTEL AND MOTOROLA MODES

PIN NAME	TYPE	DESCRIPTION
PTYPE[2:0]	I	Microprocessor Interface Mode Select Input pins These three pins are used to specify the microprocessor interface mode. The relationship between the state of these three input pins, and the corresponding microprocessor mode is presented in Table 2 .
DATA[7:0]	I/O	Bi-Directional Data Bus for register "Read" or "Write" Operations.
ADDR[11:0]	I	15-Bit Address Bus Inputs The XRT86L30 microprocessor interface uses a direct address bus. This address bus is provided to permit the user to select an on-chip register for Read/Write access.
CS	I	Chip Select Input This active low signal selects the microprocessor interface of the XRT86L30 and enables Read/Write operations with the on-chip register locations.

TABLE 4: INTEL MODE: MICROPROCESSOR INTERFACE SIGNALS

XRT86L30 PIN NAME	INTEL EQUIVALENT PIN	TYPE	DESCRIPTION
ALE	ALE	I	Address-Latch Enable: This active high signal is used to latch the contents on the address bus ADDR[11:0]. The contents of the address bus are latched into the ADDR[11:0] inputs on the falling edge of ALE.
RD	RD	I	Read Signal: This active low input functions as the read signal from the local μ P. When this pin is pulled "Low" (if \overline{CS} is "Low") the XRT86L30 is informed that a read operation has been requested and begins the process of the read cycle.
WR	WR	I	Write Signal: This active low input functions as the write signal from the local μ P. When this pin is pulled "Low" (if \overline{CS} is "Low") the XRT86L30 is informed that a write operation has been requested and begins the process of the write cycle.
RDY	RDY	O	Ready Output: This active low signal is provided by the XRT86L30 device. It indicates that the current read or write cycle is complete, and the XRT86L30 is waiting for the next command.

TABLE 5: MOTOROLA MODE: MICROPROCESSOR INTERFACE SIGNALS

XRT86L30 PIN NAME	MOTOROLA EQUIVALENT PIN	TYPE	DESCRIPTION
ALE	TS	I	Transfer Start: This active high signal is used to latch the contents on the address bus ADDR[11:0]. The contents of the address bus are latched into the ADDR[11:0] inputs on the falling edge of TS.
WR	R/W	I	Read/Write: This input pin from the local μ P is used to inform the XRT86L30 whether a Read or Write operation has been requested. When this pin is pulled "High", \overline{WE} will initiate a read operation. When this pin is pulled "Low", \overline{WE} will initiate a write operation.
RD	WE	I	Write Enable: This active low input functions as the read or write signal from the local μ P dependent on the state of R/W. When \overline{WE} is pulled "Low" (If \overline{CS} is "Low") the XRT86L30 begins the read or write operation.
No Pin	OE	I	Output Enable: This signal is not necessary for the XRT86L30 to interface to the MPC8260 or MPC860 Power PCs.
PCLK	CLKOUT	I	Synchronous Processor Clock: This signal is used as the timing reference for the Power PC synchronous mode.
RDY	TA	O	Transfer Acknowledge: This active low signal is provided by the XRT86L30 device. It indicates that the current read or write cycle is complete, and the XRT86L30 is waiting for the next command.

XRT86L30

SINGLE T1/E1/J1 FRAMER/LIU COMBO

3.1 Intel Mode Programmed I/O Access (Asynchronous)

If the XRT86L30 is interfaced to an Intel type μP , then it should be configured to operate in the Intel mode. Intel type Read and Write operations are described below.

Intel Mode Read Cycle

Whenever an Intel-type μP wishes to read the contents of a register, it should do the following.

1. Place the address of the target register on the address bus input pins ADDR[11:0].
2. While the μP is placing this address value on the address bus, the address decoding circuitry should assert the $\overline{\text{CS}}$ pin of the XRT86L30, by toggling it "Low". This action enables further communication between the μP and the XRT86L30 microprocessor interface block.
3. Toggle the ALE input pin "High". This step enables the address bus input drivers, within the microprocessor interface block of the XRT86L30.
4. The μP should then toggle the ALE pin "Low". This step causes the XRT86L30 to latch the contents of the address bus into its internal circuitry. At this point, the address of the register has now been selected.
5. Next, the μP should indicate that this current bus cycle is a Read operation by toggling the $\overline{\text{RD}}$ input pin "Low". This action also enables the bi-directional data bus output drivers of the XRT86L30.
6. After the μP toggles the Read signal "Low", the XRT86L30 will toggle the $\overline{\text{RDY}}$ output pin "Low". The XRT86L30 does this in order to inform the μP that the data is available to be read by the μP , and that it is ready for the next command.
7. After the μP detects the $\overline{\text{RDY}}$ signal and has read the data, it can terminate the Read Cycle by toggling the $\overline{\text{RD}}$ input pin "High".

NOTE: ALE can be tied "High" if this signal is not available.

The Intel Mode Write Cycle

Whenever an Intel type μP wishes to write a byte or word of data into a register within the XRT86L30, it should do the following.

1. Place the address of the target register on the address bus input pins ADDR[11:0].
2. While the μP is placing this address value on the address bus, the address decoding circuitry should assert the $\overline{\text{CS}}$ pin of the XRT86L30, by toggling it "Low". This action enables further communication between the μP and the XRT86L30 microprocessor interface block.
3. Toggle the ALE input pin "High". This step enables the address bus input drivers, within the microprocessor interface block of the XRT86L30.
4. The μP should then toggle the ALE pin "Low". This step causes the XRT86L30 to latch the contents of the address bus into its internal circuitry. At this point, the address of the register has now been selected.
5. The μP should then place the byte or word that it intends to write into the target register, on the bi-directional data bus DATA[7:0].
6. Next, the μP should indicate that this current bus cycle is a Write operation by toggling the $\overline{\text{WR}}$ input pin "Low". This action also enables the bi-directional data bus input drivers of the XRT86L30.
7. After the μP toggles the Write signal "Low", the XRT86L30 will toggle the $\overline{\text{RDY}}$ output pin "Low". The XRT86L30 does this in order to inform the μP that the data has been written into the internal register location, and that it is ready for the next command.

NOTE: ALE can be tied "High" if this signal is not available.

The Intel Read and Write timing diagram is shown in **Figure 3**. The timing specifications are shown in **Table 6**.

FIGURE 3. INTEL μ P INTERFACE SIGNALS DURING PROGRAMMED I/O READ AND WRITE OPERATIONS

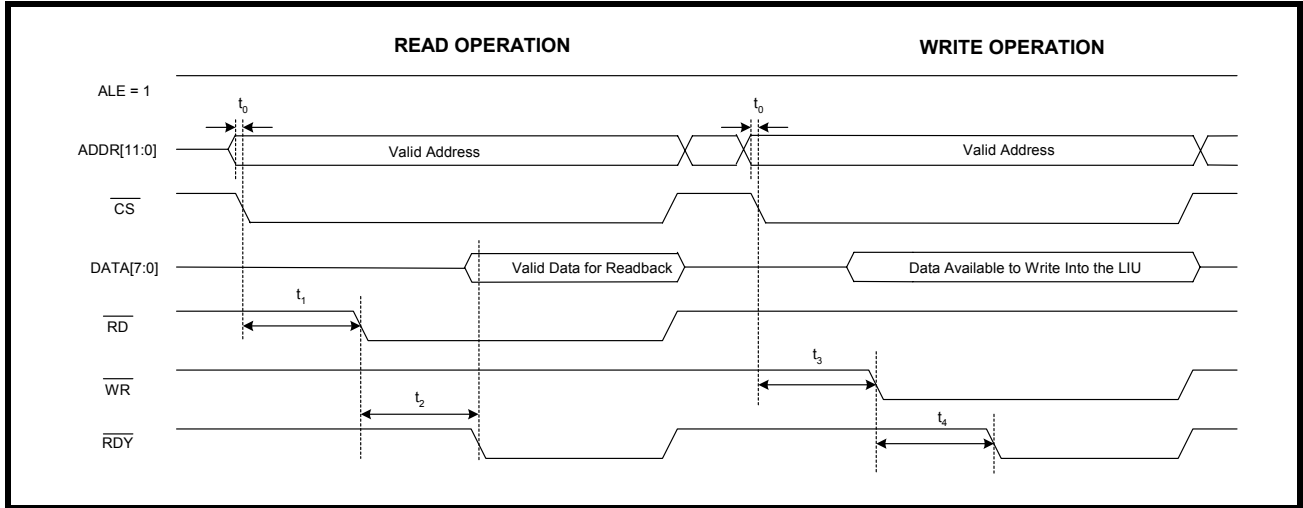

TABLE 6: INTEL MICROPROCESSOR INTERFACE TIMING SPECIFICATIONS

SYMBOL	PARAMETER	MIN	MAX	UNITS
t_0	Valid Address to \overline{CS} Falling Edge	0	-	ns
t_1	\overline{CS} Falling Edge to \overline{RD} Assert	65	-	ns
t_2	\overline{RD} Assert to \overline{RDY} Assert	-	90	ns
NA	\overline{RD} Pulse Width (t_2)	90	-	ns
t_3	\overline{CS} Falling Edge to \overline{WR} Assert	65	-	ns
t_4	\overline{WR} Assert to \overline{RDY} Assert	-	90	ns
NA	\overline{WR} Pulse Width (t_4)	90	-	ns

3.2 Motorola Mode Programmed I/O Access (Synchronous)

If the XRT86L30 is interfaced to a Motorola type μ P, it should be configured to operate in the Motorola mode. Motorola type programmed I/O Read and Write operations are described below.

Motorola Mode Read Cycle

Whenever a Motorola type μ P wishes to read the contents of a register, it should do the following.

1. Place the address of the target register on the address bus input pins ADDR[11:0].
2. While the μ P is placing this address value on the address bus, the address decoding circuitry should assert the $\overline{\text{CS}}$ pin of the XRT86L30, by toggling it "Low". This action enables further communication between the μ P and the XRT86L30 microprocessor interface block.
3. The μ P should then toggle the TS pin "Low". This step causes the XRT86L30 to latch the contents of the address bus into its internal circuitry. At this point, the address of the register has now been selected.
4. Next, the μ P should indicate that this current bus cycle is a Read operation by pulling the $\overline{\text{R/W}}$ input pin "High".
5. Toggle the $\overline{\text{WE}}$ input pin "Low". This action enables the bi-directional data bus output drivers of the XRT86L30.
6. After the μ P toggles the $\overline{\text{WE}}$ signal "Low", the XRT86L30 will toggle the $\overline{\text{TA}}$ output pin "Low". The XRT86L30 does this in order to inform the μ P that the data is available to be read by the μ P, and that it is ready for the next command.
7. After the μ P detects the $\overline{\text{TA}}$ signal and has read the data, it can terminate the Read Cycle by toggling the $\overline{\text{WE}}$ input pin "High".

Motorola Mode Write Cycle

Whenever a motorola type μ P wishes to write a byte or word of data into a register within the XRT86L30, it should do the following.

1. Place the address of the target register on the address bus input pins ADDR[11:0].
2. While the μ P is placing this address value on the address bus, the address decoding circuitry should assert the $\overline{\text{CS}}$ pin of the XRT86L30, by toggling it "Low". This action enables further communication between the μ P and the XRT86L30 microprocessor interface block.
3. The μ P should then toggle the TS pin "Low". This step causes the XRT86L30 to latch the contents of the address bus into its internal circuitry. At this point, the address of the register has now been selected.
4. Next, the μ P should indicate that this current bus cycle is a Write operation by pulling the $\overline{\text{R/W}}$ input pin "Low".
5. Toggle the $\overline{\text{WE}}$ input pin "Low". This action enables the bi-directional data bus output drivers of the XRT86L30.
6. After the μ P toggles the $\overline{\text{WE}}$ signal "Low", the XRT86L30 will toggle the $\overline{\text{TA}}$ output pin "Low". The XRT86L30 does this in order to inform the μ P that the data has been written into the internal register location, and that it is ready for the next command.
7. After the μ P detects the $\overline{\text{TA}}$ signal and has read the data, it can terminate the Read Cycle by toggling the $\overline{\text{WE}}$ input pin "High".

The Motorola Read and Write timing diagram is shown in [Figure 4](#). The timing specifications are shown in [Table 7](#).

FIGURE 4. MOTOROLA μ P INTERFACE SIGNALS DURING PROGRAMMED I/O READ AND WRITE OPERATIONS

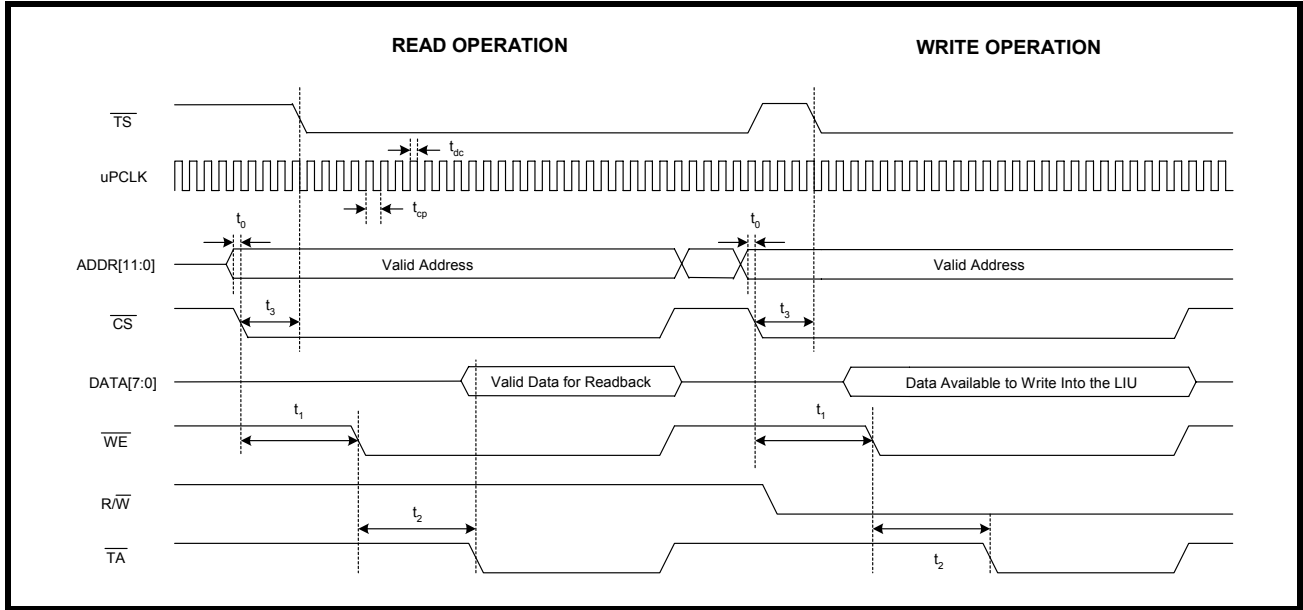

TABLE 7: INTEL MICROPROCESSOR INTERFACE TIMING SPECIFICATIONS

SYMBOL	PARAMETER	MIN	MAX	UNITS
t_0	Valid Address to \overline{CS} Falling Edge	0	-	ns
t_1	\overline{CS} Falling Edge to \overline{WE} Assert	0	-	ns
t_2	\overline{WE} Assert to \overline{TA} Assert	-	90	ns
NA	\overline{WE} Pulse Width (t_2)	90	-	ns
t_3	\overline{CS} Falling Edge to \overline{TS} Falling Edge	0	-	
t_{dc}	μ PCLK Duty Cycle	40	60	%
t_{cp}	μ PCLK Clock Period	20	-	ns

FIGURE 5. MOTOROLA 68K μ P INTERFACE SIGNALS DURING PROGRAMMED I/O READ AND WRITE OPERATIONS

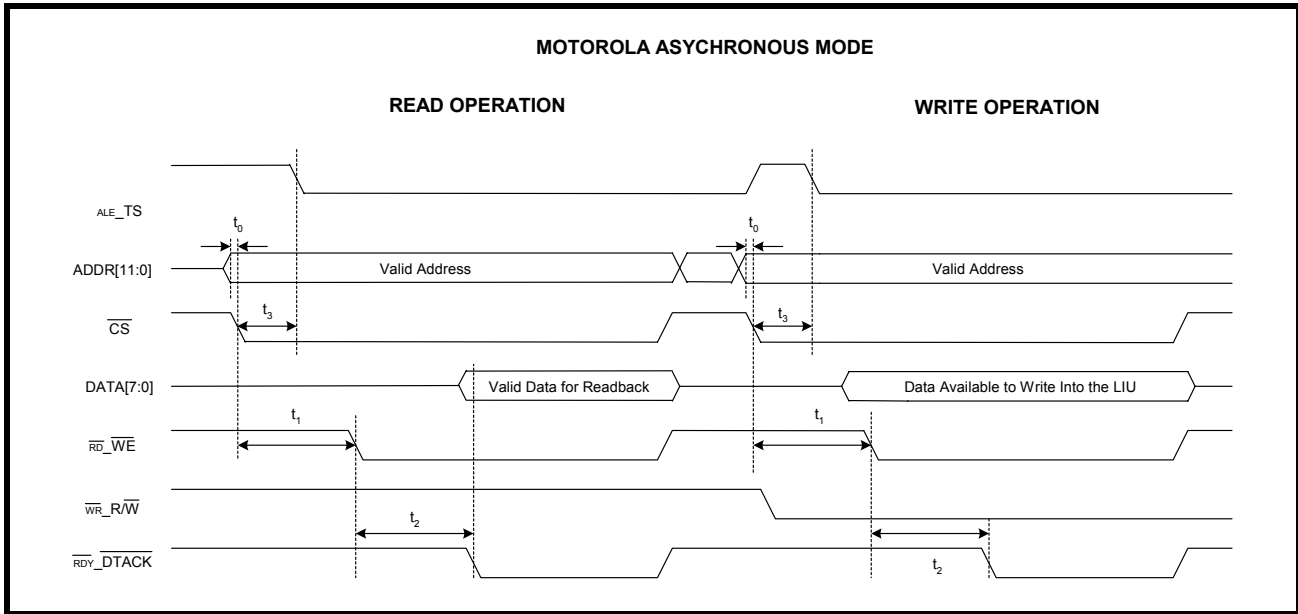

TABLE 8: MOTOROLA 68K MICROPROCESSOR INTERFACE TIMING SPECIFICATIONS

SYMBOL	PARAMETER	MIN	MAX	UNITS
t_0	Valid Address to \overline{CS} Falling Edge	0	-	ns
t_1	\overline{CS} Falling Edge to \overline{DS} (Pin $\overline{RD_WE}$) Assert	65	-	ns
t_2	\overline{DS} Assert to \overline{DTACK} Assert	-	90	ns
NA	\overline{DS} Pulse Width (t_2)	90	-	ns
t_3	\overline{CS} Falling Edge to \overline{AS} (Pin ALE_TS) Falling Edge	0	-	ns

3.2.1 DMA Read/Write Operations

The XRT86L30 Framer contains two DMA Controller Interfaces which provide support for all four framers within the chip. The purpose of the two DMA Controllers is to facilitate the rapid block transfer of data between an external memory location and the on-chip HDLC buffers via the Microprocessor Interface.

DMA-0 Write DMA Interface

DMA 0 Controller Interface handles data transfer between external memory and the selected Transmit HDLC Buffer.

The DMA cycle starts when the XRT86L30 asserts the $\overline{REQ0}$ output pin. The external DMA Controller then responds by asserting the $\overline{ACK0}$ input pin. The contents of the Microprocessor Interface bi-directional data bus are latched into the XRT86L30 each time the \overline{WR} (Write Strobe) input pin is strobed "Low".

The XRT86L30 ends the DMA cycle by negating the DMA request input ($\overline{REQ0}$) while \overline{WR} is still active. The external DMA Controller acknowledges the end of DMA Transfer by driving the $\overline{ACK0}$ input pin "High".

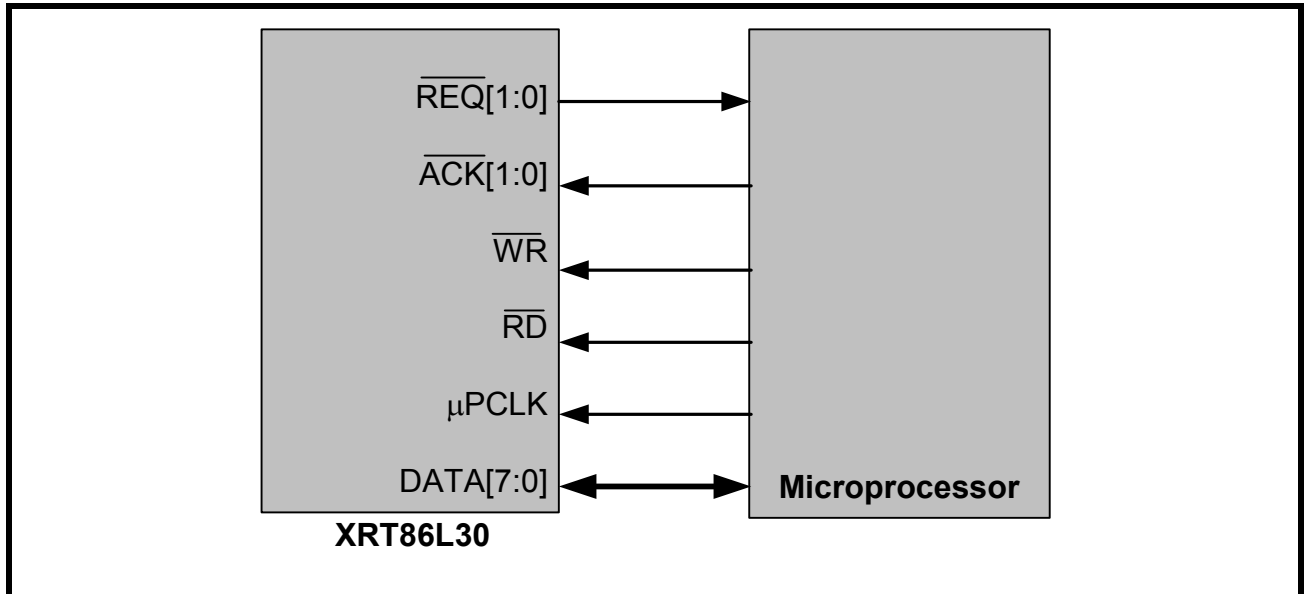
FIGURE 6. DMA MODE FOR THE XRT86L30 AND A MICROPROCESSOR

3.3 Memory Mapped I/O Addressing

TABLE 9: XRT86L30 FRAMER/LIU REGISTER MAP

ADDRESS [11:0]	CONTENTS
0100h - 01FFh	Control Register (Framer Block)
0300h - 03FFh	Time Slot (Payload) Control (Framer Block)
0500h - 05FFh	Receive Signaling Array (Framer Block)
0600h - 06FFh	LAPDn Buffer 0 (Framer Block)
0700h - 07FFh	LAPDn Buffer 1 (Framer Block)
0900h - 09FFh	Performance Monitor (Framer Block)
0B00h - 0BFFh	Interrupt Generation/Enable (Framer Block)
0C00h - 0DFFh	Reserved
0F00h - 0FFFh	Line Interface Control (LIU Block)

3.4 Description of the Control Registers

TABLE 10: REGISTER SUMMARY

REG #	FUNCTION	SYMBOL	HEX	MODE
Control Registers (0x0100 - 0x01FF)				
0	Clock and Select Register	CSR	0x0100	T1/E1
1	Line Interface Control Register	LICR	0x0101	T1/E1
2	General Purpose Input/Output Control	GPIOCR	0x0102	T1/E1
3	Reserved	-	0x0103	-
4	Reserved	-	0x0104	-
5	Reserved	-	0x0105	-
6	Reserved	-	0x0106	-
7	Framing Select Register	FSR	0x0107	E1
	Framing Select Register		0x0107	T1
8	Alarm Generation Register	AGR	0x0108	E1
	Alarm Generation Register		0x0108	T1
9	Synchronization MUX Register	SMR	0x0109	E1
	Synchronization MUX Register		0x0109	T1
10	Transmit Signaling and Data Link Select Register	TSDLSR	0x010A	E1
	Transmit Signaling and Data Link Select Register		0x010A	T1
11	Framing Control Register	FCR	0x010B	E1
	Framing Control Register		0x010B	T1
12	Receive Signaling & Data Link Select Register	RS&DLSR	0x010C	E1
	Receive Signaling & Data Link Select Register		0x010C	T1
13	Signaling Change Register 0	SCR0	0x010D	T1/E1
14	Signaling Change Register 1	SCR1	0x010E	T1/E1
15	Signaling Change Register 2	SCR2	0x010F	T1/E1
16	Signaling Change Register 3	SCR3	0x0110	E1
17	Receive National Bits Register	RNBR	0x0111	E1
18	Receive Extra Bits Register	REBR	0x0112	E1
	Receive Interface Control	RICR	0x0112	T1
19	Data Link Control Register 1	DLCR1	0x0113	T1/E1
20	Transmit Data Link Byte Count Register 1	TDLBCR1	0x0114	T1/E1
21	Receive Data Link Byte Count Register 1	RDLBCR1	0x0115	T1/E1
22	Slip Buffer Control Register	SBCR	0x0116	T1/E1

TABLE 10: REGISTER SUMMARY

REG #	FUNCTION	SYMBOL	HEX	MODE
23	FIFO Latency Register	FIFOLR	0x0117	T1/E1
24	DMA 0 (Write) Configuration Register	D0WCR	0x0118	T1/E1
25	DMA 1 (Read) Configuration Register	D1CR	0x0119	T1/E1
26	Interrupt Control Register	ICR	0x011A	T1/E1
27	LAPD Select Register	LAPDSR	0x011B	T1/E1
28	Customer Installation Alarm Generation Register	CIAGR	0x011C	T1
29	Performance Report Control Register	PRCR	0x011D	T1
30	Gapped Clock Control Register	GCCR	0x011E	T1/E1
31	Multiplexed High-Speed Channel Control Register	MHSCCR	0x011F	T1/E1
32	Transmit Interface Control Register	TICR	0x0120	E1
	Transmit Interface Control Register		0x0120	T1
33	Receive Interface Control Register	RICR	0x0122	E1
	Receive Interface Control Register		0x0122	T1
34	DS1 Test Register: PRBS Control & Status	DS1TR	0x0123	T1
35	Loopback Code Control Register	LCCR	0x0124	T1/E1
36	Transmit Loopback Code Register	TLCR	0x0125	T1/E1
37	Receive Loopback Activation Code Register	RLACR	0x0126	T1/E1
38	Receive Loopback Deactivation Code Register	RLDCR	0x0127	T1/E1
39	Transmit Sa Select Register	TSASR	0x0130	T1/E1
40	Transmit Sa Auto Control Register 1	TSACR1	0x0131	T1/E1
41	Transmit Sa Auto Control Register 2	TSACR2	0x0132	T1/E1
42	Transmit Sa4 Register	TSA4R	0x0133	T1/E1
43	Transmit Sa5 Register	TSA5R	0x0134	T1/E1
44	Transmit Sa6 Register	TSA6R	0x0135	T1/E1
45	Transmit Sa7 Register	TSA7R	0x0136	T1/E1
46	Transmit Sa8 Register	TSA8R	0x0137	T1/E1
47	Receive Sa4 Register	RSA4R	0x013B	T1/E1
48	Receive Sa5 Register	RSA5R	0x013C	T1/E1
49	Receive Sa6 Register	RSA6R	0x013D	T1/E1
50	Receive Sa7 Register	RSA7R	0x013E	T1/E1
51	Receive Sa8 Register	RSA8R	0x013F	T1/E1
52	Data Link Control Register 2	DLCR2	0x0143	T1/E1
53	Transmit Data Link Byte Count Register 2	TDLBCR2	0x0144	T1/E1

TABLE 10: REGISTER SUMMARY

REG #	FUNCTION	SYMBOL	HEX	MODE
54	Receive Data Link Byte Count Register 2	RDLBCR2	0x0145	T1/E1
55	Data Link Control Register 3	DLCR3	0x0153	T1/E1
56	Transmit Data Link Byte Count Register 3	TDLBCR3	0x0154	T1/E1
57	Receive Data Link Byte Count Register 3	RDLBCR3	0x0155	T1/E1
58	Device ID Register	DEVID	0x01FE	T1/E1
59	Version Number Register	REVID	0x01FF	T1/E1
Time Slot (payload) Control (0x0300 - 0x03FF)				
60-91	Transmit Channel Control Register 0-31	TCCR 0-31	0x0300 to 0x031F	E1
	Transmit Channel Control Register 0-23	TCCR 0-23		T1
92-123	User Code Register 0-31	TUCR 0-31	0x0320 to 0x033F	E1
	User Code Register 0-23	TUCR 0-23		T1
124-155	Transmit Signaling Control Register 0 -31	TSCR 0-31	0x0340 to 0x035F	E1
	Transmit Signaling Control Register 0-23	TSCR 0-23		T1
156-187	Receive Channel Control Register 0-31	RCCR 0-31	0x0360 to 0x037F	E1
	Receive Channel Control Register 0-23	RCCR 0-23		T1
188-219	Receive User Code Register 0-31	RUCR 0-31	0x0380 to 0x039F	E1
	Receive User Code Register 0-23	RUCR 0-23		T1
220-251	Receive Signaling Control Register 0-31	RSCR 0-31	0x03A0 to 0x03BF	E1
	Receive Signaling Control Register 0-23	RSCR 0-23		T1
252-283	Receive Substitution Signaling Register 0-31	RSSR 0-31	0x03C0 to 0x03DF	E1
	Receive Substitution Signaling Register 0-23	RSSR 0-23		T1
Receive Signaling Array (0x0500 - 0x051F)				
284-315	Receive Signaling Array Register 0	RSAR0-31	0x0500 to 0x051F	T1/E1
LAPDn Buffer 0 (0x0600 - 0x0660)				

TABLE 10: REGISTER SUMMARY

REG #	FUNCTION	SYMBOL	HEX	MODE
316-411	LAPD Buffer 0 Control Register	LAPDBCR0	0x0600 to 0x0660	T1/E1
LAPDn Buffer 1 (0x0700 - 0x0760)				
412-507	LAPD Buffer 1 Control Register	LAPDBCR1	0x0700 to 0x0760	T1/E1
Performance Monitor				
508	T1/E1 Receive Line Code Violation Counter: MSB	T1/E1 RLCVCU	0x0900	T1/E1
509	T1/E1 Receive Line Code Violation Counter: LSB	T1/E1 RLCVCL	0x0901	T1/E1
510	T1/E1 Receive Frame Alignment Error Counter: MSB	T1/E1 RFBECU	0x0902	T1/E1
511	T1/E1 Receive Frame Alignment Error Counter: LSB	T1/E1 RFAECL	0x0903	T1/E1
512	T1/E1 Receive Severely Errored Frame Counter	T1/E1RSEFC	0x0904	T1/E1
513	T1/E1 Receive Synchronization Bit (CRC-6 (T1) CRC-4 (E1) Block) Error Counter: MSB	T1/E1 RSBBECU	0x0905	T1/E1
514	T1/E1 Receive Synchronization Bit (CRC-6 (T1) CRC-4 (E1) Block) Error Counter: LSB	T1/E1 RSBBECL	0x0906	T1/E1
515	T1/E1 Receive Far-End Block Error Counter: MSB	T1/E1 RFEBECU	0x0907	T1/E1
516	T1/E1 Receive Far-End Block Error Counter: LSB	T1/E1 RFEBECL	0x0908	E1
517	T1/E1 Receive Slip Counter	T1/E1RSC	0x0909	T1/E1
518	T1/E1 Receive Loss of Frame Counter	T1/E1 RLFC	0x090A	T1/E1
519	T1/E1 Receive Change of Frame Alignment Counter	T1/E1 RCOAC	0x090B	T1/E1
520	LAPD Frame Check Sequence Error counter 1	LFCSEC1	0x090C	T1/E1
521	T1/E1 PRBS bit Error Counter: MSB	T1/E1 PBECU	0x090D	T1/E1
522	T1/E1 PRBS bit Error Counter: LSB	T1/E1 PBECL	0x090E	T1/E1
523	T1/E1 Transmit Slip Counter	T1/E1TSC	0x090F	T1/E1
524	T1/E1 Excessive Zero Violation Counter: MSB	T1/E1 EZVCU	0x910	T1/E1
525	T1/E1 Excessive Zero Violation Counter: LSB	T1/E1 EZVCL	0x911	T1/E1
526	LAPD Frame Check Sequence Error counter 2	LFCSEC2	0x91C	T1/E1
527	LAPD Frame Check Sequence Error counter 3	LFCSEC3	0x92C	T1/E1
Interrupt Generation/Enable Register Address Map (0x0B00 - 0x0B41)				
528	Block Interrupt Status Register	BISR	0x0B00	T1/E1
529	Block Interrupt Enable Register	BIER	0x0B01	T1/E1
530	Alarm & Error Interrupt Status Register	AEISR	0x0B02	T1/E1

TABLE 10: REGISTER SUMMARY

REG #	FUNCTION	SYMBOL	HEX	MODE
531	Alarm & Error Interrupt Enable Register	AEIER	0x0B03	E1
	Alarm & Error Interrupt Enable Register		0x0B03	T1
532	Framer Interrupt Status Register	FISR	0x0B04	E1
	Framer Interrupt Status Register		0x0B04	T1
533	Framer Interrupt Enable Register	FIER	0x0B05	E1
	Framer Interrupt Enable Register		0x0B05	T1
534	Data Link Status Register 1	DLSR1	0x0B06	T1/E1
535	Data Link Interrupt Enable Register 1	DLIER1	0x0B07	T1/E1
536	Slip Buffer Interrupt Status Register	SBISR	0x0B08	T1/E1
537	Slip Buffer Interrupt Enable Register	SBIER	0x0B09	T1/E1
538	Receive Loopback code Interrupt and Status Register	RLCISR	0x0B0A	T1/E1
539	Receive Loopback code Interrupt Enable Register	RLCIER	0x0B0B	T1/E1
540	Receive SA (Sa6) Interrupt Status Register	RSAISR	0x0B0C	T1/E1
541	Receive SA (Sa6) Interrupt Enable Register	RSAIER	0x0B0D	T1/E1
542	Excessive Zero Status Register	EXZSR	0x0B0E	T1/E1
543	Excessive Zero Enable Register	EXZER	0x0B0F	T1/E1
544	SS7 Status Register for LAPD 1	SS7SR1	0x0B10	T1
545	SS7 Enable Register for LAPD 1	SS7ER1	0x0B11	T1
546	Data Link Status Register 2	DLSR2	0x0B16	T1/E1
547	Data Link Interrupt Enable Register 2	DLIER2	0x0B17	T1/E1
548	SS7 Status Register for LAPD 2	SS7SR2	0x0B18	T1
549	SS7 Enable Register for LAPD 2	SS7ER2	0x0B19	T1
550	Data Link Status Register 3	DLSR3	0x0B26	T1/E1
551	Data Link Interrupt Enable Register 3	DLIER3	0x0B27	T1/E1
552	SS7 Status Register for LAPD 3	SS7SR3	0x0B28	T1
553	SS7 Enable Register for LAPD 3	SS7ER3	0x0B29	T1
554	Customer Installation Alarm Status Register	CIASR	0x0B40	T1
555	Customer Installation Alarm Interrupt Enable Register	CIAIER	0x0B41	T1

TABLE 10: REGISTER SUMMARY

REG #	FUNCTION	SYMBOL	HEX	MODE
LIU Register Summary - Channel Control Registers				
556 to 571	Channel 0 LIU Control Register	C0LIUCR	0x0F00 to 0x0F0F	T1/E1
572 to 699	Reserved	-	0x0F10 to 0x0FDF	
LIU Register Summary - Global Control Registers				
700	LIU Global Control Register 0	LIUGCR0	0x0FE0	T1/E1
701	LIU Global Control Register 1	LIUGCR1	0x0FE1	T1/E1
702	LIU Global Control Register 2	LIUGCR2	0x0FE2	T1/E1
703	LIU Global Control Register 3	LIUGCR3	0x0FE4	T1/E1
704	LIU Global Control Register 4	LIUGCR4	0x0FE9	T1/E1
705 to 731	Reserved	-	0x0FEA to 0x0FFF	-

3.4.1 Register Descriptions

TABLE 11: CLOCK SELECT REGISTER E1 MODE

REGISTER 0 - T1/E1 MODE

CLOCK SELECT REGISTER (CSR)

HEX ADDRESS: 0X0100

BIT	FUNCTION	TYPE	DEFAULT	DESCRIPTION-OPERATION
7	BPVI	R/W	0	Bipolar Violation Insertion This bit is used to force a single BPV on the transmit output of Ttip/Tring upon the transition from "0" to "1". 0 = Disabled 1 = Insert BPV
6	IST1	R/W	1	T1/E1 Mode select This bit is used to program the chip to either T1 or E1 mode. 1 = T1 mode 0 = E1 mode.
5	8kHz	R/W	0	8kHz Sync Enable This bit allows the user to configure the transmit section of the framer block to synchronize their frame alignment with the 8kHz signal derived from the MCLKIN input pin. <i>NOTE: This bit-field is ignored if TxSERCLK or the recovered line clock is used as the timing reference for the transmit section.</i>
4	CLDET	R/W	0	Clock Loss Detect Enable/Disable Select This bit enables a protection feature for the Framer whenever the recovered line clock is used as the timing source for the transmit section. If the LIU loses clock recovery, the Clock Distribution Block will detect this occurrence and automatically begin to use the LIUCLK derived from MCLKIN as the Transmit source, until the LIU is able to regain clock recovery. 0 = Disabled 1 = Enabled
3:2	Reserved	R/W	0	Reserved
1:0	CSS[1:0]	R/W	00	Clock Source Select These bits specify the timing source for the Transmit Framer block. 00 = RxLineClk - The recovered line clock is chosen as the timing reference for the transmit section of the framer (Loop Timing). 01 = TxSERCLK - The Transmit Serial Input Clock is chosen as the timing reference for the timing source for the transmit section of the framer. 10 = LIUCLK - (derived from MCLKIN) is chosen as the timing reference for the transmit section of the framer. 11 = RxLineClk - The recovered line clock is chosen as the timing reference for the transmit section of the framer (Loop Timing).

TABLE 12: LINE INTERFACE CONTROL REGISTER T1 MODE

REGISTER 1 - T1/E1 MODE

LINE INTERFACE CONTROL REGISTER (LICR)

HEX ADDRESS: 0x0101

BIT	FUNCTION	TYPE	DEFAULT	DESCRIPTION-OPERATION
7	FORCE_LOS	R/W	0	Force Transmit LOS This bit is used to force LOS to the transmit output. 0 = Disabled 1 = LOS Enabled
6	Reserved	R/W	0	Reserved
5:4	LB[1:0]	R/W	0	Framer Loopback Selection (For LIU Loopback Modes, see the LIU Configuration Registers) These two bits are used to select any of the following loop-back modes. 00 = No loopback 01 = Local loopback 10 = Remote Line Loopback 11 = Payload Loopback
3:2	Reserved	R/W	0	Reserved
1	Encode AMI/B8ZS	R/W	0	Encode AMI or B8ZS/HDB3 Line Code Select Configures the Transmit LIU Interface block to transmit data via the AMI or B8ZS/HDB3 line codes. 0 = B8ZS for DS1/HDB3 for E1 1 = AMI line code.
0	Decode AMI/B8ZS	R/W	0	Decode AMI or B8ZS/HDB3 Line Code Select Enables or disables the HDB3 decoder with in the Receive LIU interface block. 0 = Enables the B8ZS/HDB3 decoder 1 = Disables the B8ZS/HDB3 decoder

TABLE 13: GENERAL PURPOSE INPUT/OUTPUT 0 CONTROL REGISTER

REGISTER 2

GENERAL PURPOSE INPUT/OUTPUT 0 CONTROL REGISTER (GPIOCR)

HEX ADDRESS: 0x0102

BIT	FUNCTION	TYPE	DEFAULT	DESCRIPTION-OPERATION
7	GPIO0_3DIR	R/W	0	GPIO0_3 Direction This bit is used to select pin GPIO0_3 as an input or output. 0 = Input 1 = Output
6	GPIO0_2DIR	R/W	0	GPIO0_2 Direction This bit is used to select pin GPIO0_2 as an input or output. 0 = Input 1 = Output
5	GPIO0_1DIR	R/W	0	GPIO0_1 Direction This bit is used to select pin GPIO0_1 as an input or output. 0 = Input 1 = Output

TABLE 13: GENERAL PURPOSE INPUT/OUTPUT 0 CONTROL REGISTER

REGISTER 2 **GENERAL PURPOSE INPUT/OUTPUT 0 CONTROL REGISTER (GPIOCR)** **HEX ADDRESS: 0x0102**

BIT	FUNCTION	TYPE	DEFAULT	DESCRIPTION-OPERATION
4	GPIO0_0DIR	R/W	0	GPIO0_0 Direction This bit is used to select pin GPIO0_0 as an input or output. 0 = Input 1 = Output
3	GPIO0_3	R/W	0	GPIO0_3 Control If GPIO0_3DIR is set to "0", this bit is a read only register which is used to report the state of the GPIO0_3 input pin. If GPIO0_3DIR is set to "1", this bit is a write only register which is used to determine the output voltage of the GPIO0_3 pin.
2	GPIO0_2	R/W	0	GPIO0_2 Control If GPIO0_2DIR is set to "0", this bit is a read only register which is used to report the state of the GPIO0_2 input pin. If GPIO0_2DIR is set to "1", this bit is a write only register which is used to determine the output voltage of the GPIO0_2 pin.
1	GPIO0_1	R/W	0	GPIO0_1 Control If GPIO0_1DIR is set to "0", this bit is a read only register which is used to report the state of the GPIO0_1 input pin. If GPIO0_1DIR is set to "1", this bit is a write only register which is used to determine the output voltage of the GPIO0_1 pin.
0	GPIO0_0	R/W	0	GPIO0_0 Control If GPIO0_0DIR is set to "0", this bit is a read only register which is used to report the state of the GPIO0_0 input pin. If GPIO0_0DIR is set to "1", this bit is a write only register which is used to determine the output voltage of the GPIO0_0 pin.

TABLE 14: FRAMING SELECT REGISTER-E1 MODE

REGISTER 7- E1 MODE **FRAMING SELECT REGISTER (FSR)** **HEX ADDRESS: 0x0107**

BIT		FUNCTION	TYPE	DEFAULT	DESCRIPTION-OPERATION
7	E1	MODENB	R/W	0	Annex B Enable This bit forces the framing synchronizer to be compliant with ITU-T G.706 Annex B for CRC-to-non-CRC interworking detection. 0 = Normal operation. 1 = Annex B is enabled.
6	E1	CRCDIAG	R/W	0	CRC Diagnostics Select Enable/Disable This Read/Write bit-field is used to force an errored CRC pattern in the outbound CRC multiframe to be sent on the transmission line. The transmit section will implement this error by inverting the value of CRC bit (C1) 0 = Transmit E1 Framer functions normally (no errors) 1 = Transmits errored CRC bit NOTE: This bit-field is ignored if CRC multi-Framing is disabled.

TABLE 14: FRAMING SELECT REGISTER-E1 MODE

REGISTER 7- E1 MODE

FRAMING SELECT REGISTER (FSR)

HEX ADDRESS: 0x0107

BIT		FUNCTION	TYPE	DEFAULT	DESCRIPTION-OPERATION
5	E1	CASSEL(1)	R/W	0	CAS Multiframe Alignment Algorithm Select
4	E1	CASSEL(0)	R/W	0	Allows the user to select which CAS Multiframe Alignment algorithm to employ. 00 = CAS Multiframe Alignment disabled 01 = CAS Multiframe Alignment Algorithm 1 enabled 10 = CAS Multiframe Alignment Algorithm 2 (G.732) enabled 11 = CAS Multiframe Alignment disabled
3	E1	CRCSEL(1)	R/W	0	CRC Multiframe Alignment Criteria Select
2	E1	CRCSEL(0)	R/W	0	Allows the user to select which CRC-Multiframe Alignment to employ. 00 = CRC Multiframe Alignment disabled 01 = CRC Multiframe Alignment enabled. Alignment is declared if at least one valid CRC multiframe alignment signal (0,0,1,0,1,1,E1,E2) is observed within 8ms. 10 = CRC Multiframe Alignment enabled. Alignment is declared if at least two valid CRC multiframe alignment signals (0,0,1,0,1,1,E1,E2) are observed within 8ms with the time separating the two alignment signals being multiples of 2ms. 11: CRC Multiframe Alignment enabled. Alignment is declared if at least 3 valid CRC multiframe alignment signals (0,0,1,0,1,1,E1,E2) are observed within 8ms with the time separating the two alignment signals being multiples of 2ms.
1	E1	CKSEQ_ENB	R/W	0	Check Sequence Enable-FAS Alignment Enable/Disable frame check sequence in FAS alignment process. 0 = Disables Frame Check Sequence 1 = Enables Frame Check Sequence
0	E1	FASSEL	R/W	0	FAS Alignment Algorithm Select Specifies which algorithm the Receive E1 Framer block uses in its search for FAS Alignment. 0 = Algorithm 1 1 = Algorithm 2

TABLE 15: FRAMING SELECT REGISTER-T1 MODE

REGISTER 7- T1 MODE

FRAMING SELECT REGISTER (FSR)

HEX ADDRESS: 0x0107

BIT	FUNCTION	TYPE	DEFAULT	DESCRIPTION-OPERATION
7	SIGFRAME	R/W	0	Enable Signaling Update Setting this bit to 1 will enable signaling update (transmit and receive) on the superframe boundary. Otherwise, signaling data will be updated once it is received.
6	CRCDIAG	R/W	0	Force CRC Errors Setting this bit to 1 will force CRC error on transmit stream.

TABLE 15: FRAMING SELECT REGISTER-T1 MODE

REGISTER 7- T1 MODE

FRAMING SELECT REGISTER (FSR)

HEX ADDRESS: 0x0107

BIT	FUNCTION	TYPE	DEFAULT	DESCRIPTION-OPERATION
5	J1_CRC	R/W	0	CRC Calculation in J1 Mode Setting this bit to 1 will force CRC calculation for J1 format. The J1 CRC6 calculation is based on the actual values of all 4632 bits in a DS1 multiframe including Fe bits instead of assuming all Fe bits to be a one in T1 format.
4	ONEONLY	R/W	0	Allow Only One Sync Candidate Setting this bit to 1 will enable framing search engine to declare sync while there is one and only one candidate left.
3	FASTSYNC	R/W	1	Faster Sync Algorithm Setting this bit to 1 will enable framing search engine to declare SYNC condition earlier.
2 1 0	FS[2] FS[1] FS[0]	R/W R/W R/W	0 0 0	Framing Select bit 2 Framing Select bit 1 Framing Select bit 0 These three bits select the DS1 framing mode. Bit 2 is MSB and Bit 0 is LSB. <i>NOTE: Changing framing format will cause a RESYNC to be generated automatically.</i>

Framing	FS[2]	FS[1]	FS[0]
ESF	0	X	X
SF	1	0	1
N	1	1	0
T1DM	1	1	1
SLC@96	1	0	0

TABLE 16: ALARM GENERATION REGISTER - E1 MODE

REGISTER 8 -E1 MODE

ALARM GENERATION REGISTER (AGR)

HEX ADDRESS: 0x0108

BIT	FUNCTION	TYPE	DEFAULT	DESCRIPTION-OPERATION
7	AUXPG	RO	0	AUXP Generation Enables the generation of AUXP pattern which is an unframed 1010.... pattern. 0 = AUXP is disabled. 1 = AUXP is enabled.
6	LOF	R/W	0	Loss of Frame Declaration Criteria This Read/Write bit-field is used to select the LOF or Red Alarm generation criteria the Receive E1 Framer block will employ. 0 = Receive E1 Framer declares Red Alarm unless both FAS and multi-frame alignment are achieved. 1 = Prevents Receive E1 Framer from declaring Red Alarm condition; FAS Alignment is maintained.

TABLE 16: ALARM GENERATION REGISTER - E1 MODE

REGISTER 8 -E1 MODE

ALARM GENERATION REGISTER (AGR)

HEX ADDRESS: 0x0108

BIT	FUNCTION	TYPE	DEFAULT	DESCRIPTION-OPERATION
5	YEL(1)	R/W	0	<p>Yellow Alarm and Multiframe Yellow Alarm Generation</p> <p>These bits activate and deactivate the transmission of a yellow alarm. The Yellow alarm and multiframe Yellow alarm data pattern can be injected either automatically upon detection of the loss of alignment or controlled by YEL bits. Setting these bits to b01 will enable automatic yellow alarm transmission in response to a loss of frame alignment (FAS red alarm) and multiframe yellow alarm is transmitted in response to a loss of multiframe alignment (CAS red alarm). The decoding of these bits are explained as follows:</p> <p>00 = Disable the transmission of yellow alarm. 01 = Enable automatic yellow alarm generation.</p> <p>1. The yellow alarm bits (bit 3 of non-FAS frames in TS0) is transmitted by echoing the receive FAS alignment status. Logic one is transmitted if loss of FAS alignment occurred.</p> <p>2. The multiframe yellow alarm bits (bit 6 of frame 0 in TS16) is transmitted by echoing the receive CAS multiframe alignment status. Logic one is transmitted if loss of CAS multiframe alignment occurred.</p> <p>10 = Yellow and multiframe yellow alarms are transmitted as 0. 11 = Yellow and multiframe yellow alarms are transmitted as 1.</p>
4	YEL(0)	R/W	0	
3	AISG(1)	R/W	0	<p>AIS Generation Select</p> <p>These Read/Write bit-fields are used to configure the channel to generate and transmit an AIS pattern, as described below.</p> <p>00 = No AIS Alarm generated 01 = Enable unframed AIS alarm generation 10 = Enable AIS16 generation 11 = Enable framed AIS alarm generation</p>
2	AISG(0)	R/W	0	
1	AISD(1)	R/W	0	<p>AIS Pattern Detection Select</p> <p>These Read/Write bit-fields are used to specify the type of AIS pattern that the receive E1 framer block will detect as described below.</p> <p>00 = AIS alarm detection is disabled. 01 = Enable unframed AIS alarm detection. 10 = Enable AIS 16 detection. 11 = Enable framed AIS alarm detection.</p>
0	AISD(0)	R/W	0	

TABLE 17: ALARM GENERATION REGISTER -T1 MODE

REGISTER 8 - T1 MODE

ALARM GENERATION REGISTER (AGR)

HEX ADDRESS: 0x0108

BIT	FUNCTION	TYPE	DEFAULT	DESCRIPTION-OPERATION
7	Reserved	-	-	Reserved
6	LOF	R/W	0	<p>Loss of Frame Declaration Criteria</p> <p>A Red Alarm is generated by the receiver to indicate the loss of frame (LOF) alignment. A Yellow Alarm is then returned to the remote transmitter to report that the receiver detects LOF. Setting this bit will set the criteria for preventing red alarm from generation as long as the frame is aligned. Otherwise, the frame and multiframe must be both aligned in order to keep red alarm from happening.</p>

TABLE 17: ALARM GENERATION REGISTER -T1 MODE

REGISTER 8 - T1 MODE

ALARM GENERATION REGISTER (AGR)

HEX ADDRESS: 0x0108

BIT	FUNCTION	TYPE	DEFAULT	DESCRIPTION-OPERATION
5	YEL(1)	R/W	0	<p>Yellow Alarm and Multiframe Yellow Alarm Generation</p> <p>These bits activate and deactivate the transmission of a yellow alarm. The decoding of these bits are explained as follows:</p> <p>00, = Disable the transmission of yellow alarm.</p> <p>01 = In SF mode (or N mode), yellow alarm is transmitted as bit 2 = 0 (second MSB) in all DS0 data channel. In T1DM mode, yellow is transmitted to the remote terminal by setting the outgoing Y-bit to zero. In ESF mode, follow the following scenario:</p> <p>1. If YEL[0] forms a pulse width shorter or equal to the time required to transmit 255 pattern of 1111_1111_0000_0000 (eight ones followed by eight zeros) on the 4-kbit/s data link (M1-M12), the alarm is transmitted for 255 patterns.</p> <p>2. If YEL[0] is a pulse width longer than the time required to transmit 255 patterns, the alarm continues until TYEL[0] goes low.</p> <p>3. A second YEL[0] pulse during an alarm transmission resets the pattern counter and extends the alarm duration for another 255 patterns.</p> <p>10 = In SF mode, yellow alarm is transmitted as a "1" for the Fs bit of frame 12, this is yellow alarm for J1 standard. In T1DM mode, yellow is transmitted to the remote terminal by setting the outgoing Y-bit to zero. In ESF mode, yellow alarm is controlled by the duration of YEL[1]. This allows continuous alarms of any length.</p> <p>11 = Disable the transmission of yellow alarm.</p>
4	YEL(0)	R/W	0	
3	AISG(1)	R/W	0	<p>AIS Generation Select</p> <p>These Read/Write bit-fields are used to configure the channel to generate and transmit an AIS pattern, as described below.</p> <p>00 = No AIS Alarm generated</p> <p>01 = Enable unframed AIS alarm generation</p> <p>10 = No AIS Alarm generated</p> <p>11 = Enable framed AIS alarm generation</p>
2	AISG(0)	R/W	0	
1	AISD(1)	R/W	0	<p>AIS Pattern Detection Select</p> <p>These Read/Write bit-fields are used to specify the type of AIS pattern that the receive E1 framer block will detect as described below.</p> <p>00 = Disabled</p> <p>01 = Unframed AIS alarm detection</p> <p>10 = AIS16 detection</p> <p>11 = Unframed AIS alarm detection</p>
0	AISD(0)	R/W	0	

TABLE 18: SYNCHRONIZATION MUX REGISTER - E1 MODE

REGISTER 9 - E1 MODE

SYNCHRONIZATION MUX REGISTER (SMR)

HEX ADDRESS: 0x0109

BIT	FUNCTION	TYPE	DEFAULT	DESCRIPTION-OPERATION
7-6	ESRC[1:0]	R/W	0	Source for E bits These bits determine where the E bits should be inserted from. 00 = Transparent, inserted from the status of receiver. 01 = 0. 10 = 1. 11 = Data link.
5	Reserved	-	-	Reserved
4	SYNC INV	R/W	0	Sync Inversion Select Selects the direction of the transmit sync and multisync signals. 0 = Syncs are input if the CSS(1:0) bits of CSR equal 01 (TxSerClk input is selected as the timing reference for the Transmit section of the framer); otherwise syncs are outputs 1 = Syncs are output if CSS(1:0) bits of CSR equal 01 (TxSerClk input is selected as the timing reference for the Transmit section of the framer); otherwise syncs are inputs
3	DLSRC(1)	R/W	0	Data Link Source Select
2	DLSRC(0)	R/W	0	Specifies the source of the Data Link bits that will be inserted in the outbound E1 frames. 00 = TxSER Input: Transmit Payload data Input port will be source of Data Link bits. 01 = TX HDLC Controller: Transmit HDLC Controller will generate either BOS (Bit Oriented Signaling) or MOS (Message Oriented Signaling) messages which will be inserted into the Data Link bit-fields in the outbound E1 frames. 10 = TxOH_n Input: Transmit Overhead data Input Port will be the source of the Data Link bits. 11 = TxSer_n Input: Transmit Payload data Input port will be the source of the Data Link Bits.

TABLE 18: SYNCHRONIZATION MUX REGISTER - E1 MODE

REGISTER 9 - E1 MODE

SYNCHRONIZATION MUX REGISTER (SMR)

HEX ADDRESS: 0x0109

BIT	FUNCTION	TYPE	DEFAULT	DESCRIPTION-OPERATION
1	CRCSRC	R/W	0	CRC-4 Bits Source Select This Read/Write bit-field is used to configure the transmit section of the channel to use either internal generation or the TxSER_n input pin as the source of the CRC-4 bits inserted into the outbound frames. 0 = Internally Generated and inserted into E1 data stream internally. 1 = Tx_SER Input: Transmit Payload data Input port will be source of CRC-4 bits. <i>NOTE: This bit-field is ignored if CRC Multiframe Alignment is disabled</i>
0	FSRC	R/W	0	Framing Alignment Bits Source Select Specifies source of the Framing Alignment bits, which include FAS alignment bits, multiframe alignment bits, E and A bits. 0 = Internally generated and inserted into the outbound E1 frames. 1 = TxSer_n Input: Transmit Serial Input port will be source of the FAS bits, CRC Multiframe Alignments and the E and A bits.

TABLE 19: SYNCHRONIZATION MUX REGISTER - T1 MODE

REGISTER 9 - T1 MODE

SYNCHRONIZATION MUX REGISTER (SMR)

HEX ADDRESS: 0x0109

BIT	FUNCTION	TYPE	DEFAULT	DESCRIPTION-OPERATION
7	Reserved	-	-	Reserved
6	MFRAMEALIGN	R/W	0	Multiframe Alignment This bit forces transmit frame counter aligns with the backplane multiframe sync. 0 = The multiframe alignment is not enforced from backplane interface. 1 = The transmit multiframe is aligned with the incoming backplane multiframe timing.
5	MSYNC	R/W	0	Tx Super Frame Sync This bit selects the transmit input sync signal from either the frame sync or superframe sync signals. 0 = Sync input (TxSync) is a frame sync. In 1.544MHz clock mode, TxMSync is used, in other clock mode, TxMSync is an input transmit clock. 1 = Sync input is a superframe sync.
4	SYNC INV	R/W	0	Sync Inversion Select This bit changes the direction of transmit sync and multi-sync signals. 0 = The syncs are inputs if CSS bits of CSR equal to 1, otherwise, syncs are outputs. 1 = The syncs are outputs if CSS bits of CSR equal to 1, otherwise, syncs are inputs.

TABLE 19: SYNCHRONIZATION MUX REGISTER - T1 MODE

REGISTER 9 - T1 MODE

SYNCHRONIZATION MUX REGISTER (SMR)

HEX ADDRESS: 0x0109

BIT	FUNCTION	TYPE	DEFAULT	DESCRIPTION-OPERATION
3 - 2	Reserved	-	-	Reserved
1	CRCSRC	R/W	0	CRC-6 Bits Source Select This bit determines where the CRC-6 bits should be inserted from. 0 = The CRC-6 bits are generated and inserted internally. 1 = The CRC-6 bits are passed through from the input serial data only when IOMUX=0 and CSS < 3. NOTE: This bit-field is ignored if CRC Multiframe Alignment is disabled
0	FSRC	R/W	0	Framing Alignment Bits Source Select Determines where the framing alignment bits should be inserted from. 0 = The framing alignment bits are inserted internally. 1 = The framing alignment bits are passed through from the input serial data only when IOMUX=0 and CSS < 3.

TABLE 20: TRANSMIT SIGNALING AND DATA LINK SELECT REGISTER - E1 MODE

REGISTER 10 - E1 MODE

TRANSMIT SIGNALING AND DATA LINK SELECT REGISTER (TSDLR)

HEX ADDRESS:0x010A

BIT	FUNCTION	TYPE	DEFAULT	DESCRIPTION-OPERATION
7	TxSa8ENB	R/W	0	Specifies if the Sa8 bit-field (bit 7 within timeslot 0 of non-FAS frames) will be involved in the transport of Data Link Information 0 = Data Link Interface does not use Sa8 bit-field. Sa8 bit-field within each outbound non-FAS frame will be set to 1. 1 = Data Link Interface uses Sa8 bit-field. NOTE: This bit-field is only active when the TxSIGDL[2:0] bits within this register are set to 00x. This bit-field is ignored in all other case.
6	TxSa7ENB	R/W	0	Specifies if the Sa7 bit-field (bit 6 within timeslot 0 of non-FAS frames) will be involved in the transport of Data Link Information 0 = Data Link Interface does not use Sa7 bit-field. Sa7 bit-field within each outbound non-FAS frame will be set to 1. 1 = Data Link Interface uses Sa7 bit-field. NOTE: This bit-field is only active when the TxSIGDL[2:0] bits within this register are set to 00x. This bit-field is ignored in all other cases.
5	TxSa6ENB	R/W	0	Specifies if the Sa6 bit-field (bit 5 within timeslot 0 of non-FAS frames) will be involved in the transport of Data Link Information 0 = Data Link Interface does not use Sa6 bit-field. Sa6 bit-field within each outbound non-FAS frame will be set to 1. 1 = Data Link Interface uses Sa6 bit-field. NOTE: This bit-field is only active when the TxSIGDL[2:0] bits within this register are set to 00x. This bit-field is ignored in all other case.

TABLE 20: TRANSMIT SIGNALING AND DATA LINK SELECT REGISTER - E1 MODE

REGISTER 10 - E1 MODE TRANSMIT SIGNALING AND DATA LINK SELECT REGISTER (TSDLR) HEX ADDRESS:0X010A

BIT	FUNCTION	TYPE	DEFAULT	DESCRIPTION-OPERATION
4	TxSa5ENB	R/W	0	Specifies if the Sa5 bit-field (bit 4 within timeslot 0 of non-FAS frames) will be involved in the transport of Data Link Information 0 = Data Link Interface does not use Sa5 bit-field. Sa5 bit-field within each outbound non-FAS frame will be set to 1. 1 = Data Link Interface uses Sa5 bit-field. NOTE: This bit-field is only active when the TxSIGDL[2:0] bits within this register are set to 00x. This bit-field is ignored in all other case.
3	TxSa4ENB	R/W	0	Specifies if the Sa4 bit-field (bit 3 within timeslot 0 of non-FAS frames) will be involved in the transport of Data Link Information 0 = Data Link Interface does not use Sa4 bit-field. Sa4 bit-field within each outbound non-FAS frame will be set to 1. 1 = Data Link Interface uses Sa4 bit-field. NOTE: This bit-field is only active when the TxSIGDL[2:0] bits within this register are set to 00x. This bit-field is ignored in all other case.
2	TxSIGDL(2)	R/W	0	These three Read/Write bits are used to specify the type of data that is to be transported via D/E channel, National Bits in timeslot 0 of the non-FAS frames, and Timeslot 16 in the outbound frames.
1	TxSIGDL(1)	R/W	0	
0	TxSIGDL(0)	R/W	0	

TABLE 21: TRANSMIT SIGNALING AND DATA LINK SELECT REGISTER - T1 MODE

REGISTER 10 - T1 MODE TRANSMIT SIGNALING AND DATA LINK SELECT REGISTER (TSDLR) HEX ADDRESS:0X010A

BIT	FUNCTION	TYPE	DEFAULT	DESCRIPTION-OPERATION
7	Reserved	-	-	Reserved
6	Reserved	-	-	Reserved

TABLE 21: TRANSMIT SIGNALING AND DATA LINK SELECT REGISTER - T1 MODE

REGISTER 10 - T1 MODE TRANSMIT SIGNALING AND DATA LINK SELECT REGISTER (TSDLR) HEX ADDRESS:0x010A

BIT	FUNCTION	TYPE	DEFAULT	DESCRIPTION-OPERATION
5	TxDLBW[1]	R/W	0	Data Link Bandwidth
		R/W	0	00 = FDL is a 4kHz data link channel
4	TxDLBW[0]	R/W	0	01 = FDL is a 2kHz data link channel carried by odd framing bits (1,5,9,...) 10 = FDL is a 2kHz data link channel carried by even framing bits(3,7,11...)
3	TxDE[1]	R/W	0	DE Select
				00 = The D/E time slots are inserted from TxSER.
2	TxDE[0]	R/W	0	01 = The D/E time slots are inserted from the LAPD controller. 10 = The D/E time slots are inserted from the serial signaling input. 11 = The D/E time slots are inserted from the fractional input.
1	TxDL[1]	R/W	0	DL Select
0	TxDL[0]	R/W	0	00 = LAPD Controller/SLC96 Buffer. The data link bits are inserted from the LAPD controller. (LAPD1 is the only controller that can be used to transport LAPD messages through the data link bits) 01 = Serial Input. The data link bits are inserted from serial data input. 10 = Overhead Input. The data link bits are inserted from overhead input. 11 = None (forced to 1). The data link bits are forced to 1.

TABLE 22: FRAMING CONTROL REGISTER E1 MODE

REGISTER 11 -- E1 MODE FRAMING CONTROL REGISTER (FCR) HEX ADDRESS: 0x010B

BIT	FUNCTION	TYPE	DEFAULT	DESCRIPTION-OPERATION
7	RSYNC	R/W	0	Force Re-Synchronization A 0 to 1 transition in this bit-field forces the Receive E1 Framer to restart the synchronization process. This bit field is automatically cleared (set to 0) after frame synchronization is reached.
6	CASC(1)	R/W	0	Loss of CAS Multiframe Alignment Criteria Select
5	CASC(0)	R/W	0	These two Read/Write bits are used to select the Loss of CAS Multi-frame Alignment Declaration criteria. The relationship between the state of these two bit fields and the corresponding Loss of CAS Multi-Frame is presented below. 00 = Two consecutive CAS Multi-Frames with Multiframe Alignment Signal (MAS) errors 01 = Three consecutive CAS Multi-Frames with MAS errors 10 = Four consecutive CAS Multi-Frames with MAS errors 11 = Eight consecutive CAS Multi-Frames with MAS errors NOTE: These bits are only active if Channel Associated Signaling is used.

TABLE 22: FRAMING CONTROL REGISTER E1 MODE

REGISTER 11 -- E1 MODE

FRAMING CONTROL REGISTER (FCR)

HEX ADDRESS: 0x010B

BIT	FUNCTION	TYPE	DEFAULT	DESCRIPTION-OPERATION
4	CRCC(1)	R/W	0	Loss of CRC-4 Multiframe Alignment Criteria Select Selects criteria for Loss of CRC-4 Multiframe Alignment. 00 = Four consecutive CRC Multiframe Alignment signals have been received in error 01 = Two consecutive CRC Multiframe Alignment signals have been received in error 10 = Eight consecutive CRC Multiframe Alignment signals have been received in error 11 = 915 or more CRC-4 errors have been detected in one second. NOTE: These bit-fields are ignored if CRC Multiframe Alignment has been disabled.
3	CRCC(0)	R/W	0	
2	FASC(2)	R/W	0	Loss of FAS Alignment Criteria Select These three Read/Write bits are used to select Loss of FAS Frame Declaration criteria. The relationship between the state of these bits and the corresponding Loss of FAS Frame declaration is presented below. 000 = Illegal - do not use 001 = 1 errored FAS pattern 010 = 2 consecutive errored FAS patterns 011 = 3 consecutive errored FAS patterns 100 = 4 consecutive errored FAS patterns 101 = 5 consecutive errored FAS patterns 110 = 6 consecutive errored FAS patterns 111 = 7 consecutive errored FAS patterns
1	FASC(1)	R/W	1	
0	FASC(0)	R/W	1	

TABLE 23: FRAMING CONTROL REGISTER T1 MODE

REGISTER 11 -- T1 MODE

FRAMING CONTROL REGISTER (FCR)

HEX ADDRESS: 0x010B

BIT	FUNCTION	TYPE	DEFAULT	DESCRIPTION-OPERATION
7	RSYNC	R/W	0	Force Re-Synchronization A 0 to 1 transition in this bit-field forces the Receive DS1 Framer to restart the synchronization process. This bit field is automatically cleared (set to 0) after frame synchronization is reached.
6	CRCENB/ ONEONLY	R/W	0	Sync with CRC verification in ESF. (Assuming only one Ft sync candidate exists.) 0 = No CRC match test 1 = Include CRC match test as part of Synchronization criteria.
5	TOLR[2]	R/W	0	Tolerance Bits [2:0] The Tolerance (TOLR) and Range (RANG) form the criteria for loss of frame alignment. A loss of frame is declared if there is "TOLR out of RANG" errors in the framing pattern. The recommended TOLR value is 2. NOTE: A "0" value for TOLR is internally blocked. A TOLR value must be specified.
4	TOLR[1]	R/W	1	
3	TOLR[0]	R/W	0	

TABLE 23: FRAMING CONTROL REGISTER T1 MODE

REGISTER 11 -- T1 MODE FRAMING CONTROL REGISTER (FCR) HEX ADDRESS: 0x010B

BIT	FUNCTION	TYPE	DEFAULT	DESCRIPTION-OPERATION
2	RANG[2]	R/W	1	Range Bits [2:0] The Tolerance (TOLR) and Range (RANG) form the criteria for loss of frame alignment. A loss of frame is declared if there is "TOLR out of RANG" errors in the framing pattern. The recommended RANG value is 5. NOTE: A "0" value for RANG is internally blocked. A RANG value must be specified.
1	RANG[1]	R/W	0	
0	RANG[0]	R/W	1	

TABLE 24: RECEIVE SIGNALING & DATA LINK SELECT REGISTER - E1 MODE

REGISTER 12 - E1 MODE RECEIVE SIGNALING & DATA LINK SELECT REGISTER (RS&DLSR) HEX ADDRESS: 0x010C

BIT	FUNCTION	TYPE	DEFAULT	DESCRIPTION-OPERATION
7	RxSa8ENB	R/W	0	This Read/Write bit is used to specify whether or not data link information will be transported via National Bit Sa8 (bit 7 within timeslot 0 of non-FAS frames) 0 = Sa8 does not carry data link information 1 = Sa8 carries data link information NOTE: This bit-field is valid only if the RxSIGDL[2:0] = "000" or "001". (The National bits have been configured to carry data link bits).
6	RxSa7ENB	R/w	0	This Read/Write bit is used to specify whether or not data link information will be transported via National Bit Sa7 (bit 6 within timeslot 0 of non-FAS frames) 0 = Sa7 does not carry data link information 1 = Sa7 carries data link information NOTE: This bit-field is valid only if the RxSIGDL[2:0] = "000" or "001". (The National bits have been configured to carry data link bits).
5	RxSa6ENB	R/W	0	This Read/Write bit is used to specify whether or not data link information will be transported via National Bit Sa6 (bit 5 within timeslot 0 of non-FAS frames) 0 = Sa6 does not carry data Link information 1 = Sa6 carries data link information NOTE: This bit-field is valid only if the RxSIGDL[2:0] = "000" or "001". (The National bits have been configured to carry data link bits).
4	RxSa5ENB	R/W	0	This Read/Write bit is used to specify whether or not data link information will be transported via National Bit Sa5 (bit 4 within timeslot 0 of non-FAS frames) 0 = Sa5 does not carry data link information 1 = Sa5 carries data link information NOTE: This bit-field is valid only if the RxSIGDL[2:0] = "000" or "001". (The National bits have been configured to carry data link bits).

TABLE 24: RECEIVE SIGNALING & DATA LINK SELECT REGISTER - E1 MODE

REGISTER 12 - E1 MODE RECEIVE SIGNALING & DATA LINK SELECT REGISTER (RS&DLSR) HEX ADDRESS: 0x010C

BIT	FUNCTION	TYPE	DEFAULT	DESCRIPTION-OPERATION
3	RxSa4ENB	R/W	0	This Read/Write bit is used to specify whether or not data link information will be transported via National Bit Sa4 (bit 3 within timeslot 0 of non-FAS frames) 0 = Sa4 does not carry data link information 1 = Sa4 carries data link information NOTE: This bit-field is valid only if the RxSIGDL[2:0] = "000" or "001". (If the National bits have been configured to carry data link bits).
2	RxSIGDL(2)	R/W	0	These three Read/Write bits are used to specify the type of data that is to be extracted via D/E channel, National Bits in timeslot 0 of the non-FAS frames, and Timeslot 16 in the outbound frames. D/E Channel 0xx = Fractional Output 1xx = Serial Signaling Output <u>National Bits (Sa4-8)</u> 000 = Data Link Data extracted from National bits 001 = Data Link Data extracted from National bits 010 = National bits forced to 1, not used to carry data link data 011 = None (forced to 1) 1xx = Data Link Data extracted from National bits Timeslot 16 000 = Timeslot 16 is taken directly from PCM 001 = CAS Signaling bits A,B,C,D (per time slot) 010 = CCS Signaling bits A,B,C,D 011 = CAS Signaling bits A,B,C,D (per time slot) 1xx = Timeslot 16 is taken directly from PCM
1	RxSIGDL(1)	R/W	0	
0	RxSIGDL(0)	R/W	0	

TABLE 25: RECEIVE SIGNALING & DATA LINK SELECT REGISTER (RS&DLSR) T1 MODE

REGISTER 12 - T1 MODE RECEIVE SIGNALING & DATA LINK SELECT REGISTER (RS&DLSR) HEX ADDRESS: 0x010C

BIT	FUNCTION	TYPE	DEFAULT	DESCRIPTION-OPERATION
7	Reserved	-	-	Reserved
6	Reserved	-	-	Reserved
5	RxDLBW[1]	R/W	0	Data Link Bandwidth 00 = FDL is a 4kHz data link channel. 01 = FDL is a 2kHz data link channel carried by old framing bits(1,5,9,....). 10 = FDL is a 2kHz data link channel carried by even framing bits(3,7,11,....).
4	RxDLBW[0]	R/w	0	
3	RxDE[1]	R/W	0	DE Select
2	RxDE[0]	R/W	0	00 = The D/E time slots are output to RxSER. 01 = The D/E time slots are output to the LAPD controller. 10 = The D/E time slots are output to the serial signaling output. 11 = The D/E time slots are output to the fractional output.

TABLE 25: RECEIVE SIGNALING & DATA LINK SELECT REGISTER (RS&DLSR) T1 MODE

REGISTER 12 - T1 MODE RECEIVE SIGNALING & DATA LINK SELECT REGISTER (RS&DLSR) HEX ADDRESS: 0x010C

BIT	FUNCTION	TYPE	DEFAULT	DESCRIPTION-OPERATION
1	RxDL[1]	R/W	0	DL Select 00 = LAPD Controller/SLC96 Buffer. The data link bits are extracted from the LAPD controller. (LAPD1 is the only controller that can be used to extract LAPD messages through the data link bits) 01 = Serial Input. The data link bits are extracted to the serial data output. 10 = Overhead Input. The data link bits are extracted to the overhead output. 11 = None (forced to 1). The data link bits are forced to 1.
0	RxDL[0]	R/W	0	

TABLE 26: SIGNALING CHANGE REGISTER 0 - T1 MODE

REGISTER 13 - T1/E1 MODE SIGNALING CHANGE REGISTER 0 (SCR 0) HEX ADDRESS: 0x010D

BIT	FUNCTION	TYPE	DEFAULT	DESCRIPTION-OPERATION
7	Ch. 0	RUR	0	These Reset Upon Read bits indicate whether the signaling data associated with Channels 0-7 has changed since the last read of this register. 0 = Signaling data has not changed since last read of register 1 = Signaling data has changed since last read of register NOTE: For E1, Ch. 0 is not applicable since it carries FAS and National Bits in alternating frames. This register is only relevant if the Framing Channel is using Channel Associated Signaling
6	Ch. 1	RUR	0	
5	Ch.2	RUR	0	
4	Ch.3	RUR	0	
3	Ch.4	RUR	0	
2	Ch.5	RUR	0	
1	Ch.6	RUR	0	
0	Ch.7	RUR	0	

TABLE 27: SIGNALING CHANGE REGISTER 1

REGISTER 14 T1/E1 MODE SIGNALING CHANGE REGISTER 1 (SCR 1) HEX ADDRESS: 0x010E

BIT	FUNCTION	TYPE	DEFAULT	DESCRIPTION-OPERATION
7	Ch.8	RUR	0	These Reset Upon Read bits indicate whether the signaling data associated with Channels 8-15 has changed since the last read of this register. 0 = Signaling data has not changed since last read of register 1 = Signaling data has changed since last read of register NOTE: This register is only relevant if the Framing Channel is using Channel Associated Signaling
6	Ch.9	RUR	0	
5	Ch.10	RUR	0	
4	Ch.11	RUR	0	
3	Ch.12	RUR	0	
2	Ch.13	RUR	0	
1	Ch.14	RUR	0	
0	Ch.15	RUR	0	

TABLE 28: SIGNALING CHANGE REGISTER 2

REGISTER 15 T1/E1 MODE

SIGNALING CHANGE REGISTER 2 (SCR 2)

HEX ADDRESS: 0x010F

BIT	FUNCTION	TYPE	DEFAULT	DESCRIPTION-OPERATION
7	Ch.16	RUR	0	These Reset Upon Read bits indicate whether the signaling data associated with Channels 16-23 has changed since the last read of this register. 0 = Signaling data has not changed since last read of register 1 = Signaling data has changed since last read of register <i>NOTE: This register is only relevant if the Framing Channel is using Channel Associated Signaling</i>
6	Ch.17	RUR	0	
5	Ch.18	RUR	0	
4	Ch.19	RUR	0	
3	Ch.20	RUR	0	
2	Ch.21	RUR	0	
1	Ch.22	RUR	0	
0	Ch.23	RUR	0	

TABLE 29: SIGNALING CHANGE REGISTER 3

REGISTER 16 - E1 MODE

SIGNALING CHANGE REGISTER 3 (SCR 3)

HEX ADDRESS: 0x0110

BIT	FUNCTION	TYPE	DEFAULT	DESCRIPTION-OPERATION
7	Ch.24	RUR	0	These Reset Upon Read bits indicate whether the signaling data associated with Channels 24-31 has changed since the last read of this register. 0 = Signaling data has not changed since last read of register 1 = Signaling data has changed since last read of register <i>NOTE: This register is only relevant if the Framing Channel is using Channel Associated Signaling</i>
6	Ch.25	RUR	0	
5	Ch.26	RUR	0	
4	Ch.27	RUR	0	
3	Ch.28	RUR	0	
2	Ch.29	RUR	0	
1	Ch.30	RUR	0	
0	Ch.31	RUR	0	

TABLE 30: RECEIVE NATIONAL BITS REGISTER

REGISTER 17

RECEIVE NATIONAL BITS REGISTER (RNBR)

HEX ADDRESS: 0x0111

BIT	FUNCTION	TYPE	DEFAULT	DESCRIPTION-OPERATION
7	Si_FAS	RO	x	Received International Bit - FAS Frame This Read Only bit-field contains the value of the International Bit in the most recently received FAS frame
6	Si_nonFAS	RO	x	Received International Bit - Non FAS Frame This Read Only bit-field contains the value of the International Bit in the most recently received non-FAS frame
5	R_ALARM	RO	x	Received FAS Yellow Alarm This Read Only bit-field contains the value in the Remote Alarm bit-field (frame Yellow Alarm) within the non-FAS frame.

TABLE 30: RECEIVE NATIONAL BITS REGISTER

REGISTER 17

RECEIVE NATIONAL BITS REGISTER (RNBR)

HEX ADDRESS: 0x0111

BIT	FUNCTION	TYPE	DEFAULT	DESCRIPTION-OPERATION
4	Sa4	RO	x	Received National Bits These Read Only bit-fields contain the values of the National bits within the most recently received non-FAS frame.
3	Sa5	RO	x	
2	Sa6	RO	x	
1	Sa7	RO	x	
0	Sa8	RO	x	

TABLE 31: RECEIVE EXTRA BITS REGISTER

REGISTER 18

RECEIVE EXTRA BITS REGISTER (REBR)

HEX ADDRESS: 0x0112

BIT	FUNCTION	TYPE	DEFAULT	DESCRIPTION-OPERATION
7	IF Detection	RO	0	In Frame Detection (DS1/E1) This register bit is used to indicate whether the receive framer is In Frame or out of Frame. 0 = Out of Frame 1 = In Frame
6-4	Reserved	-	-	Reserved
3	EX1	RO	x	Extra Bit 1 Corresponds to value in bit 5 within timeslot 16 of frame 0 of the signaling multiframe
2	ALARMFE	RO	x	CAS Multi-Frame Yellow Alarm Corresponds to value in bit 6(CAS Multiframe Yellow Alarm) within timeslot 16 of frame 0 of the signaling multiframe. 0 = Remote E1 transmitting terminal is not sending CAS Multiframe Yellow Alarm 1 = Remote E1 transmitting terminal is sending CAS Multiframe Yellow Alarm
1	EX2	RO	x	Extra Bit 2 Corresponds to value in Bit 7 within timeslot 16 of frame 0 of the signaling multiframe
0	EX3	RO	x	Extra Bit 3 Corresponds to value in Bit 8 within timeslot 16 of frame 0 of the signaling multiframe

NOTE: The value of bits [3:0] within this register only have meaning if the framer is using Channel Associated Signaling.

TABLE 32: DATA LINK CONTROL REGISTER
REGISTER 19
DATA LINK CONTROL REGISTER 1 (DLCR1)
HEX ADDRESS: 0x0113

BIT	FUNCTION	TYPE	DEFAULT	DESCRIPTION-OPERATION
7	SLC-96	R/W	0	SLC@96 Enable, 6 bit for ESF If SLC@96 framing is selected, setting this bit high will enable SLC@96 data link transmission; Otherwise, the regular SF framing bits are transmitted. In ESF framing mode, setting this bit high will cause facility data link to transmit/receive SLC@96-like message.
6	MOSA	R/W	0	MOS Abort Enable/Disable Select This Read/Write bit-field is used to configure the transmit HDLC1 controller to automatically transmit an abort sequence anytime it transitions from the MOS mode to the BOS mode. 0 = Transmit HDLC1 Controller inserts an MOS abort sequence if the MOS message is interrupted 1 = Prevents Transmit HDLC1 Controller from inserting an MOS abort sequence.
5	Rx_FCS_DIS	R/W	0	Receive FCS Verification Disable Enables/Disables Receive HDLC1 Controller's computation and verification of the FCS value in the incoming LAPD message frame 0 = Verifies FCS value of each MOS frame. 1 = Does not verify FCS value of each MOS frame.
4	AutoRx	R/W	0	Auto Receive LAPD Message Configures the Rx HDLC1 Controller to discard any incoming LAPD Message frame that exactly match which is currently stored in the Rx HDLC1 buffer. 0 = Disabled 1 = Enables this feature.
3	Tx_ABORT	R/W	0	Transmit ABORT Configures the Tx HDLC1 Controller to transmit an ABORT sequence (string of 7 or more consecutive 1's) to the Remote terminal. 0 = Tx HDLC1 Controller operates normally 1 = Tx HDLC1 Controller inserts an ABORT sequence into the data link channel.
2	Tx_IDLE	R/W	0	Transmit Idle (Flag Sequence Byte) Configures the Tx HDLC1 controller to transmit a string of Flag Sequence octets (0X7E) in the data link channel to the Remote terminal. 0 = Tx HDLC1 Controller resumes transmitting data to the Remote terminal 1 = Tx HDLC1 Controller transmits a string of Flag Sequence bytes. NOTE: This bit-field is ignored if the Tx HDLC1 controller is operating in the BOS Mode - bit-field 0(MOS/BOS) within this register is set to 0.

TABLE 32: DATA LINK CONTROL REGISTER

REGISTER 19

DATA LINK CONTROL REGISTER 1 (DLCR1)

HEX ADDRESS: 0x0113

BIT	FUNCTION	TYPE	DEFAULT	DESCRIPTION-OPERATION
1	Tx_FCS_EN	R/W	0	<p>Transmit LAPD Message with FCS</p> <p>Configure HDLC1 Controller to include/not include FCS octets in the outbound LAPD message frames.</p> <p>0 = Does not include FCS octets into the outbound LAPD message frame.</p> <p>1 = Inserts FCS octets into the outbound LAPD message frame.</p> <p>NOTE: This bit-field is ignored if the transmit HDLC1 controller has been configured to operate in the BOS mode.</p>
0	MOS/BOS	R/W	0	<p>Message Oriented Signaling/Bit Oriented Signaling Select</p> <p>Specifies whether the TxRx HDLC1 Controller will be transmitting and receiving LAPD message frames (MOS) or Bit Oriented Signal (BOS) messages.</p> <p>0 = Tx/Rx HDLC1 Controller transmits and receives BOS messages.</p> <p>1 = Tx/Rx HDLC1 Controller transmits and receives MOS messages.</p>

TABLE 33: TRANSMIT DATA LINK BYTE COUNT REGISTER

REGISTER 20

TRANSMIT DATA LINK BYTE COUNT REGISTER 1 (TDLBCR1)

HEX ADDRESS: 0x0114

BIT	FUNCTION	TYPE	DEFAULT	DESCRIPTION-OPERATION
7	BUFAVAL//BUFSEL	R/W	0	<p>Transmit HDLC1 Buffer Available/Buffer Select</p> <p>Specifies which of the two Tx HDLC1 Buffers that the Tx HDLC1 controller should read from to generate the next outbound HDLC1 message.</p> <p>0 = transmits message data residing in Tx HDLC1 Buffer 0.</p> <p>1 = transmits message data residing in Tx HDLC1 buffer 1.</p> <p>NOTE: If one of these Tx HDLC1 buffers contain a message which has yet to be completely read-in and processed for transmission by the Tx HDLC1 controller, then this bit-field will automatically reflect the value corresponding to the available buffer. Changing this bit-field to the in-use buffer is not permitted.</p>
6	TDLBC6	R/W	0	Transmit HDLC1 Message - Byte Count
5	TDLBC5	R/W	0	Depends on whether an MOS or BOS message is being transmitted to the Remote Terminal Equipment
4	TDLBC4	R/W	0	<p>If BOS message is being transmitted: These bit fields contain the number of repetitions the BOS message must be transmitted before the Tx HDLC1 controller generates the TxEOt interrupt and halts transmission. If these fields are set to 00000000, then the BOS message will be transmitted for an indefinite number of times.</p> <p>If MOS message is being transmitted: These bit fields contain the length, in number of octets, of the message to be transmitted.</p>
3	TDLBC3	R/W	0	
2	TDLBC2	R/W	0	
1	TDLBC1	R/W	0	
0	TDLBC0	R/W	0	

TABLE 34: RECEIVE DATA LINK BYTE COUNT REGISTER
REGISTER 21
RECEIVE DATA LINK BYTE COUNT REGISTER 1 (RDLBCR1)
HEX ADDRESS: 0x0115

BIT	FUNCTION	TYPE	DEFAULT	DESCRIPTION-OPERATION
7	RBUFPTR	R/W	0	Receive HDLC1 Buffer-Pointer Identifies which RxHDLC1 buffer contains the newly received HDLC1 message. 0 = HDLC1 message is stored in Rx HDLC1 Buffer 0. 1 = HDLC1 message is stored in Rx HDLC1 Buffer 1.
6	RDLBC6	R/W	0	Receive HDLC Message - byte count In MOS Mode These seven bit-fields contain the size in bytes of the HDLC1 message that has been extracted and written into the Rx HDLC1 buffer. In BOS Mode These bits should be set to the value of the message repetitions before each receive interrupt. If they are set to "0", no RxEOT interrupt will be generated.
5	RDLBC5	R/W	0	
4	RDLBC4	R/W	0	
3	RDLBC3	R/W	0	
2	RDLBC2	R/W	0	
1	RDLBC1	R/W	0	
0	RDLBC0	R/W	0	

TABLE 35: SLIP BUFFER CONTROL REGISTER
REGISTER 22
SLIP BUFFER CONTROL REGISTER (SBCR)
HEX ADDRESS: 0x0116

BIT	FUNCTION	TYPE	DEFAULT	DESCRIPTION-OPERATION
7	TxSB_ISFIFO	R/W	0	Selects slip buffer as a FIFO for all clock modes while TxClk and TxSerClk are synced. 0 = Buffer acts as slip buffer if enabled. 1 = Buffer acts as a FIFO. The data latency is dictated by FIFO Latency.
6-5	Reserved	-	-	Reserved
4	SB_FORCESF	R/W	0	Force Signaling Freeze Setting this bit "High" stops further signal updating until this bit is cleared. 1 = Signaling array is not updated. 0 = Signaling array is updated only if SB_ENB[1:0] = 01 or 10
3	SB_SFENB	R/W	0	Signal Freeze Enable This bit enables signaling freeze for one multiframe after buffer slipping. 1 = Signaling freeze is enabled. 0 = Signaling freeze is disabled.
2	SB_SDIR	R/W	1	Slip Buffer (RxSync) Direction Select Allows RxSync output pin to be an input or an output. 0 = RxSync is an output pin 1 = RxSync is an input pin

TABLE 35: SLIP BUFFER CONTROL REGISTER

REGISTER 22

SLIP BUFFER CONTROL REGISTER (SBCR)

HEX ADDRESS: 0x0116

BIT	FUNCTION	TYPE	DEFAULT	DESCRIPTION-OPERATION
1	SB_ENB(1)	R/w	0	Slip Buffer Mode Select
0	SB_ENB(0)	R/W	0	Selects mode of operation of slip buffer. 00 = Buffer is bypassed and RxSync and RxSERCIk are outputs. 01 = Elastic store slip buffer enabled. RxSERCIk is an input. 10 = Buffer acts as FIFO Data latency dictated by the setting within the FIFO Latency Register. RxSERCIk is an input. 11 = Buffer is bypassed. RxSync and RxSERCIk are outputs.

TABLE 36: FIFO LATENCY REGISTER

REGISTER 23

FIFO LATENCY REGISTER (FFOLR)

HEX ADDRESS: 0x0117

BIT	FUNCTION	TYPE	DEFAULT	DESCRIPTION-OPERATION
7-5	Reserved	-	-	Reserved
4-0	Latency	R/W	0	Sets the distance between slip buffer read and slip buffer write pointers in FIFO mode.

TABLE 37: DMA 0 (WRITE) CONFIGURATION REGISTER

REGISTER 24

DMA 0 WRITE CONFIGURATION REGISTER (D 0 WCR)

HEX ADDRESS: 0x0118

BIT	FUNCTION	TYPE	DEFAULT	DESCRIPTION-OPERATION
7	DMA0 RST	R/W	0	DMA_0 Reset Resets transmit DMA 0 channel. 0 = Normal operation. 1 = A zero to one transition resets DMA channel_0.
6	DMA0 ENB	R/W	0	DMA_0 Enable Enables DMA_0 interface. 0 = Disables DMA_0 interface 1 = Enables DMA_0 interface
5	WR TYPE	R/W	0	Write Type Select Selects function of \overline{WR} signal. 0 = \overline{WR} functions as direction signal (indicates whether the current bus cycle is a read or write operation) and \overline{RD} functions as a data strobe signal. 1 = \overline{WR} functions as a write strobe signal and \overline{RD} functions as configured in the DMA 1 configuration register.
4 - 3	Reserved	-	-	Reserved

TABLE 37: DMA 0 (WRITE) CONFIGURATION REGISTER

REGISTER 24

DMA 0 WRITE CONFIGURATION REGISTER (D 0 WCR)

HEX ADDRESS: 0x0118

BIT	FUNCTION	TYPE	DEFAULT	DESCRIPTION-OPERATION
2	DMA0_CHAN(2)	R/W	0	Channel Select Selects which channel, within the chip, is to use the DMA_0 (Write) interface. 000 = Channel 0 001 = Channel 1 010 = Channel 2 011 = Channel 3 100 = Channel 4 101 = Channel 5 110 = Channel 6 111 = Channel 7
1	DMA0_CHAN(1)	R/W	0	
0	DMA0_CHAN(0)	R/W	0	

TABLE 38: DMA 1 (READ) CONFIGURATION REGISTER

REGISTER 25

DMA 1 (READ) CONFIGURATION REGISTER (D1CR)

HEX ADDRESS: 0x0119

BIT	FUNCTION	TYPE	DEFAULT	DESCRIPTION-OPERATION
7-6	Reserved	-	-	Reserved
7	DMA1_RST	R/W	0	DMA_1 Reset Resets the DMA 1 Channel 0 = Normal operation. 1 = A zero to one transition resets DMA channel.
6	DMA1_ENB	R/W	0	DMA1_ENB Enables DMA_1 interface 0 = Disables DMA_1 interface 1 = Enables DMA_1 interface
5	RD TYPE	R/W	0	Selects the function of pRD_L signal. 0 = RD functions as a Read Strobe signal 11 = RD acts as a direction signal, WR works as a data strobe.
4 - 3	Reserved	-	-	Reserved
2	DMA1_CHAN(2)	R/W	0	Channel Select Selects which channel, within the chip, is to use the DMA_1 interface. 000 = Channel 0 001 = Channel 1 010 = Channel 2 011 = Channel 3 100 = Channel 4 101 = Channel 5 110 = Channel 6 111 = Channel 7
1	DMA1_CHAN(1)	R/W	0	
0	DMA1_CHAN(0)	R/W	0	

TABLE 39: INTERRUPT CONTROL REGISTER

REGISTER 26

INTERRUPT CONTROL REGISTER (ICR)

HEX ADDRESS: 0x011A

BIT	FUNCTION	TYPE	DEFAULT	DESCRIPTION-OPERATION
7-3	Reserved	-	-	Reserved
2	INT_WC_RUR	R/W	0	Interrupt Write-to-Clear or Reset-upon-Read Select Configures Interrupt Status bits to either Reset Upon Read or Write-to-Clear 0=Interrupt Status bit RUR 1=Interrupt Status bit Write-to-Clear
1	ENBCLR	R/W	0	Interrupt Enable Auto Clear 0=Interrupt Enable bits are not cleared after status reading 1=Interrupt Enable bits are cleared after status reading
0	INTRUP_ENB	R/W	0	Interrupt Enable for Framer_n Enables Framer n for Interrupt Generation. 0 = Disables corresponding framer block for Interrupt Generation 1 = Enables corresponding framer block for Interrupt Generation

TABLE 40: LAPD SELECT REGISTER

REGISTER 27

LAPD SELECT REGISTER (LAPDSR)

HEX ADDRESS: 0x011B

BIT	FUNCTION	TYPE	DEFAULT	DESCRIPTION-OPERATION
[7:2]	Reserved	-	-	These bits are reserved
[1:0]	LAPDsel	R/W	0	LAPD Select Bits [1:0] determine which HDLC controller has access to the Read/Write registers 0x0600 and 0x0700 for storing or extracting LAPD messages. 00 = HDLC Controller 1 01 = HDLC Controller 2 10 = HDLC Controller 3 11 = HDLC Controller 1

TABLE 41: CUSTOMER INSTALLATION ALARM GENERATION REGISTER

REGISTER 28 - T1 CUSTOMER INSTALLATION ALARM GENERATION REGISTER (CIAGR) HEX ADDRESS: 0x011C

BIT	FUNCTION	TYPE	DEFAULT	DESCRIPTION-OPERATION
[7:4]	Reserved	-	-	These bits are reserved
[3:2]	CIAG	R/W	0	CI Alarm Transmit (Only in ESF) Alarm Indication Signal-Customer Installation (AIS-CI) and Remote Alarm Indication-Customer Installation (RAI-CI) are intended for use in a network to differentiate between an issue within the network or the CI. AIS-CI is an all ones signal with an embedded signature of 01111100 11111111 right-to left which recurs at 386 bit intervals in the DS-1 signal. 00 = No CI alarm generation 01 = Enable unframed AIS-CI alarm generation 10 = Enable RAI-CI generation 11 = No CI alarm generation
[1:0]	CIAD	R/W	0	CI Alarm Detect (Only in ESF) 00 = CI alarm detection is disabled 01 = Enable unframed AIS-CI alarm detection 10 = Enable RAI-CI detection 11 = CI alarm detection is disabled

TABLE 42: PERFORMANCE REPORT CONTROL REGISTER

REGISTER 29 - T1 PERFORMANCE REPORT CONTROL (PRCR) HEX ADDRESS: 0x011D

BIT	FUNCTION	TYPE	DEFAULT	DESCRIPTION-OPERATION
[7:2]	Reserved	-	-	These bits are reserved
[1:0]	APCR	R/W	0	Automatic Performance Control/Response Report These bits automatically generates a summary report of the PMON status so that it can be inserted into an out going LAPD message. 00 = No performance report issued 01 = Single performance report issued when a write of 00 follows by a write of 01 10 = Automatically issues a performance report every one second 11 = No performance report issued

TABLE 43: GAPPED CLOCK CONTROL REGISTER

REGISTER 30 - T1/E1

GAPPED CLOCK CONTROL REGISTER (GCCR)

HEX ADDRESS: 0x011E

BIT	FUNCTION	TYPE	DEFAULT	DESCRIPTION-OPERATION
7	FrOutclk	R/W	0	Framer Output Clock Reference By default, the output clock reference on T1OSCCLK and E1OSCCLK output pins is 1.544MHz/2.048MHz respectively. By setting this bit to a "1", the output clock reference is 49.408MHz/65.536MHz for T1/E1 respectively. 0 = Standard T1/E1 Rate 1 = High-Speed Rate
[6:2]	Reserved	-	-	These bits are reserved
1	TxGCCR	R/W	0	Transmit Gapped Clock Interface This bit is used to select a gapped clock interface operating at 2.048Mbit/s in DS-1 mode. In this application, 63 gaps (missing data) are inserted so that the overall bit rate is reduced to 1.544Mbit/s. (In this mode, TxMSYNC is used as the 2.048MHz Gapped Clock Input. TxSER is used as the 2.048MHz Gapped Data Input. TxSERCLK must be 1.544MHz.) 0 = Disabled 1 = Transmit gapped clock for the Transmit Path
0	RxGCCR	R/W	0	Receive Gapped Clock Interface This bit is used to select a gapped clock interface operating at 2.048Mbit/s in DS-1 mode. In this application, 63 gaps (missing data) are inserted so that the overall bit rate is reduced to 1.544Mbit/s. (In this mode, RxSERCLK should be configured as an input so that a 2.048MHz Gapped Clock can be applied to the Framer block. RxSER is used as the 2.048MHz Gapped Data Output. The position of the gaps will be determined by the gaps placed in RxSERCLK by the user.) 0 = Disabled 1 = Receive gapped clock for the Receive Path

TABLE 44: GAPPED CLOCK CONTROL REGISTER

REGISTER 31 - T1/E1

MULTIPLEXED ()

HEX ADDRESS: 0x011F

BIT	FUNCTION	TYPE	DEFAULT	DESCRIPTION-OPERATION
7:2	Reserved	R/W	-	Reserved
1:0	MHSCCR[1:0]	R/W	00	Multiplexed High-Speed Channel Control These bits are used to select which channel (the channel position can be chosen from 1 of 4 different time slots) within the High-Speed serial data is to be processed by the framer. The other three channels will be don't care bits, since this is a single channel device. This allows the XRT86L30 to be compatible with High-Speed modes such as HMOVIP/H.100, etc. 00 = Channel 0 01 = Channel 1 10 = Channel 2 11 = Channel 3

Registers 0x1B thru 0x1F unused.

TABLE 45: TRANSMIT INTERFACE CONTROL REGISTER - E1 MODE
REGISTER 32 - E1 MODE
TRANSMIT INTERFACE CONTROL REGISTER (TICR)
HEX ADDRESS:0x0120

BIT	FUNCTION	TYPE	DEFAULT	DESCRIPTION-OPERATION
7	TxSyncFrD	R/W	0	Tx Synchronous fraction data interface 0 = Fractional data is clocked into the chip using TxChCLK 1 = Fractional data is clocked in to the chip using TxSerClk (ungapped). TxChn[4:0] still indicates the time slot number if TxFr2048 is not 1, TxIMODE[1:0] = 00, and TxMUXEN = 0. TxChClk is used as fractional data enable.
6	Reserved	-	-	Reserved
5	TxPLClkEnb	R/W	0	Tx payload clock enable 1 = TxSerClk will output Tx clock with OH bit period blocked in 2.048Hz clock output mode.
	TxSync is Low	R/W	0	TxSync is Low In H.100 and HMVIP Mode 0 = TxSync is active "Low" 1 = TxSync is active "High"
4	TxFr2048	R/W	0	If TxMUXEN = 0 and TxIMODE[1:0] = 00 0 = TxChn[4:0] outputs the channel number as usual. 1 = TxChn[0]/TxSig inputs signaling information and TxChn[1]/TxFrTD will input fractional channel data in 2.048 Mbit mode. Note; This bit has no effect while either TxMUXEN = 1 or TxIMODE[1:0] = 00, TxChn[4:0] signals input TxSig and fractional data.
3	TxICLKINV	R/W	0	Clock Inversion 0 = Data transition happens on rising edge of the transmit clocks. 1 = Data transition happens on falling edge of the transmit clocks.
2	TxMUXEN	R/W	0	Mux Enable 0 = No channel multiplexing. 1 = Four channels are multiplexed in single serial stream.

TABLE 45: TRANSMIT INTERFACE CONTROL REGISTER - E1 MODE

REGISTER 32 - E1 MODE TRANSMIT INTERFACE CONTROL REGISTER (TICR) HEX ADDRESS:0x0120

BIT	FUNCTION	TYPE	DEFAULT	DESCRIPTION-OPERATION
1	TxIMODE[1]	R/W	0	Tx Interface Mode selection
0	TxIMODE[0]	R/W	0	<p>This mode selection determines the interface speed.</p> <p>When TxMUXEN = 0,</p> <p>00 = Transmit interface is taking data at a rate of 2.048Mbit/s.</p> <p>01 = Transmit interface is taking data at a rate of 2.048Mbit/s.</p> <p>10 = Transmit interface is taking data at a rate of 4.096Mbit/s.</p> <p>11 = Transmit interface is taking data at a rate of 8.192Mbit/s.</p> <p>When TxMUXEN = 1,</p> <p>00 = Reserved</p> <p>01 = Transmit interface is taking data at a rate of 16.384Mbit/s from channel 0 and bit-demultiplexing into 4 channels from to the LIU outputs on channels 0 through 3. The TxSYNC pulse remains “High” during the first bit of each E1 frame.</p> <p>10 = Transmit interface is taking data at a rate of 16.384Mbit/s from channel 0 and byte-demultiplexing into 4 channels from to the LIU outputs on channels 0 through 3 (HMOVIP Mode). The TxSYNC pulse remains “High” during the last two bits of the previous E1 frame and the first two bits of the current E1 frame.</p> <p>11 = Transmit interface is taking data at a rate of 16.384Mbit/s from channel 0 and byte-demultiplexing into 4 channels from to the LIU outputs on channels 0 through 3 (H.100 Mode). The TxSYNC pulse remains “High” during the last bit of the previous E1 frame and the first bit of the current E1 frame.</p> <p>NOTE: Channel 4 is de-multiplexed into the LIU outputs at channel 4 through 7.</p>

TABLE 46: TRANSMIT INTERFACE CONTROL REGISTER - T1 MODE

REGISTER 32 - T1 MODE TRANSMIT INTERFACE CONTROL REGISTER (TICR) HEX ADDRESS:0x0120

BIT	FUNCTION	TYPE	DEFAULT	DESCRIPTION-OPERATION
7	TxSyncFrD	R/W	0	<p>Transmit Synchronous Fractional Data Interface</p> <p>0 = Fractional data is clocked into the chip using TxChCLK</p> <p>1 = Fractional data is clocked in to the chip using TxSerClk (ungapped). TxChn[4:0] still indicates the time slot number if TxFr1544 is not 1, TxIMODE[1:0] = 00, and TxMUXEN = 0. TxChClk is used as fractional data enable.</p>
6	Reserved	-	-	Reserved
5	TxPLClkEnb	R/W	0	<p>Transmit Payload Clock Enable</p> <p>1 = TxSerClk will output Tx clock with OH bit period blocked in 1.544MHz clock output mode.</p>
	TxSync Is Low		0	<p>TxSync is Low</p> <p>In H.100 and HMOVIP Mode</p> <p>0 = TxSync is active “Low”</p> <p>1 = TxSync is active “High”</p>

TABLE 46: TRANSMIT INTERFACE CONTROL REGISTER - T1 MODE

REGISTER 32 - T1 MODE

TRANSMIT INTERFACE CONTROL REGISTER (TICR)

HEX ADDRESS:0x0120

BIT	FUNCTION	TYPE	DEFAULT	DESCRIPTION-OPERATION
4	TxFr1544	R/W	0	<p>If TxMUXEN = 0 and TxIMODE[1:0] = 00 0 = TxChn[4:0] will output the channel number as usual. 1 = TxChn[0]/TxSig will input signaling information and TxChn[1]/TxFrTD will input fractional channel data in 1.544 Mbit mode.</p> <p>NOTE: This bit has no effect while either TxMUXEN = 1 or TxIMODE[1:0] = 00, TxChn[4:0] signals input TxSig and fractional data.</p>
3	TxICLKINV	R/W	0	<p>Clock Inversion 0 = Data transition occurs on rising edge of the transmit clock. 1 = Data transition occurs on falling edge of the transmit clock.</p>
2	TxMUXEN	R/W	0	<p>Mux Enable 0 = No channel multiplexing. 1 = Four channels are multiplexed in single serial stream.</p>
1	TxIMODE[1]	R/W	0	<p>Tx Intf Mode selection</p>
0	TxIMODE[0]	R/W	0	<p>This mode selection determines the interface speed.</p> <p>When TxMUXEN = 0 00 = Transmit interface is taking data at a rate of 1.544Mbit/s. 01 = Transmit interface is taking data at a rate of 2.048Mbit/s. 10 = Transmit interface is taking data at a rate of 4.096Mbit/s. 11 = Transmit interface is taking data at a rate of 8.192Mbit/s.</p> <p>When TxMUXEN = 1, 00 = Transmit interface is taking data at a rate of 12.352Mbit/s from channel 0 and bit-demultiplexing into 4 channels from to the LIU outputs on channels 0 through 3. The TxSYNC pulse remains "High" during the framing bit of each DS-1 frame. 01 = Transmit interface is taking data at a rate of 16.384Mbit/s from channel 0 and bit-demultiplexing into 4 channels from to the LIU outputs on channels 0 through 3. The TxSYNC pulse remains "High" during the framing bit of each DS-1 frame. 10 = Transmit interface is taking data at a rate of 16.384Mbit/s from channel 0 and byte-demultiplexing into 4 channels from to the LIU outputs on channels 0 through 3 (HMOVIP Mode). The TxSYNC pulse remains "High" during the last two bits of the previous DS-1 frame and the first two bits of the current DS-1 frame. 11 = Transmit interface is taking data at a rate of 16.384Mbit/s from channel 0 and byte-demultiplexing into 4 channels from to the LIU outputs on channels 0 through 3 (H.100 Mode). The TxSYNC pulse remains "High" during the last bit of the previous DS-1 frame and the first bit of the current DS-1 frame.</p> <p>NOTE: Channel 4 is de-multiplexed into the LIU outputs at channel 4 through 7.</p>

TABLE 47: RECEIVE INTERFACE CONTROL REGISTER (RICR) - E1 MODE

Register 33 - E1 Mode

RECEIVE INTERFACE CONTROL REGISTER (RICR)

0x0122

BIT	FUNCTION	TYPE	DEFAULT	DESCRIPTION-OPERATION
7	RxSyncFrD	R/W	0	Rx synchronous fractional data interface 0 = Fractional data is clocked out from the chip using RxChCLK 1 = RxChClk is used to output fractional data enable instead of being fraction data clock. In this mode, fractional data is clocked out of the chip using RxSerClk (ungapped). RxChn still indicates the time slot number if RxFr2048 is not 1, RxIMODE[1:0] = 0, and RxMUXEN = 0.
6	Reserved	-	-	Reserved
5	RxPLClkEnb/	R/W	0	Rx Payload Clock Enable 1 = RxSerClk outputs Rx clock with OH bit period blocked while in 2.048MHz clock output mode.
	RxSyncislow			RxSync is low In H.100 and HMVIP Mode 1 = RxSync active low. 0 = RxSync active high.
4	RxFr2048	R/W	0	Clock Inversion 1 = RxChn[0]/RxSig outputs signaling information, RxChn[1]/RxFrTD will output fractional channel data in 2.048 MHz mode and RxChn[2] will output the serial channel number of each time slot. 0 = RxChn[4:0] outputs the parallel channel number as usual.
3	RxICLKINV	N/A	0	Clock Inversion 0 = Data transition happens on the rising edge of the transmit clocks. 1 = Data transition happens on the falling edge of the transmit clocks.
2	RxMUXEN	R/W	0	Mux Enable 0 = No channel Multiplexing. 1 = Four channels are multiplexed in single serial stream.

TABLE 47: RECEIVE INTERFACE CONTROL REGISTER (RICR) - E1 MODE

Register 33 - E1 Mode

RECEIVE INTERFACE CONTROL REGISTER (RICR)

0x0122

BIT	FUNCTION	TYPE	DEFAULT	DESCRIPTION-OPERATION
1	RxIMODE[1]	R/W	0	Rx Intf Mode Selection
0	RxIMODE[0]	R/W	0	<p>This mode selection determines the interface speed.</p> <p>When RxMUXEN = 0</p> <p>00 = Receive interface is presenting data at a rate of 2.048Mbit/s.</p> <p>01 = Receive interface is presenting data at a rate of 2.048Mbit/s.</p> <p>10 = Receive interface is presenting data at a rate of 4.096Mbit/s.</p> <p>11 = Receive interface is presenting data at a rate of 8.192Mbit/s.</p> <p>When RxMUXEN = 1</p> <p>00 = Reserved</p> <p>01 = Receive interface is taking data from the four LIU input channels 0 through 3 and byte-multiplexing into the serial output channel 0. The TxSYNC pulse remains "High" during the framing bit of each E1 frame.</p> <p>10 = Receive interface is taking data from the four LIU input channels 0 through 3 and byte-multiplexing into the serial output channel 0 (HMVIP Mode). The TxSYNC pulse remains "High" during the last two bits of the previous E1 frame and the first two bits of the current E1 frame.</p> <p>11 = Receive interface is taking data from the four LIU input channels 0 through 3 and byte-multiplexing into the serial output channel 0 (H.100 Mode). The TxSYNC pulse remains "High" during the last bit of the previous E1 frame and the first bit of the current E1 frame.</p> <p>NOTE: Channels 4 through 7 are multiplexed into the serial output at channel 4.</p>

TABLE 48: RECEIVE INTERFACE CONTROL REGISTER (RICR) - T1 MODE

Register 33 - T1 Mode

RECEIVE INTERFACE CONTROL REGISTER (RICR)

0x0122

BIT	FUNCTION	TYPE	DEFAULT	DESCRIPTION-OPERATION
7	RxSyncFrD	R/W	0	<p>Rx synchronous fractional data interface</p> <p>1 = RxChClk is used to output fractional data instead of being fraction data clock. In this mode, fractional data is clocked out of the chip using RxSerClk (ungapped). RxChn still indicates the time slot number if RxFr1544 is not 1, RxIMODE[1:0] = 00, and RxMUXEN = 0.</p> <p>RxCclk will be a valid signal for fractional data output (RxFrTD) if RxFr1544 is 1 or RxIMODE[1:0] = 00 or RxMUXEN = 0</p>
6	Reserved	-	-	Reserved
5	RxPLClkEnb/	R/W	0	<p>Rx Payload Clock Enable</p> <p>1 = RxSerClk will output Rx clock with OH bit period blocked while in 1.544MHz clock output mode.</p>
	RxSyncislow			<p>RxSync is low</p> <p>In H.100 and HMVIP Mode</p> <p>1 =Rx Sync active low.</p> <p>0 = RxSync active high.</p>

TABLE 48: RECEIVE INTERFACE CONTROL REGISTER (RICR) - T1 MODE

Register 33 - T1 Mode RECEIVE INTERFACE CONTROL REGISTER (RICR) 0x0122

BIT	FUNCTION	TYPE	DEFAULT	DESCRIPTION-OPERATION
4	RxFr1544	R/W	0	Clock Inversion/RxSig 1 = RxChn[0]/RxSig outputs signaling information, RxChn[1]/RxFrTD will output fractional channel data in 1.544 MHz mode and RxChn[2] will output the serial channel number of each time slot. 0 = RxChn[4:0] outputs the parallel channel number as usual.
3	RxICLKINV	N/A	0	Clock inversion 0 = Data transition happens on the rising edge of the transmit clocks. 1 = Data transition happens on the falling edge of the transmit clocks.
2	RxMUXEN	R/W	0	Mux Enable 0 = No channel Multiplexing. 1 = Four channels are multiplexed in single serial stream.
1	RxIMODE[1]	R/W	0	Rx Interface Mode selection
0	RxIMODE[0]	R/W	0	This mode selection determines the interface speed. When RxMUXEN = 0, 00 = Receive interface is presenting data at a rate of 1.544Mbit/s. 01 = Receive interface is presenting data at a rate of 2.048Mbit/s. 10 = Receive interface is presenting data at a rate of 4.096Mbit/s. 11 = Receive interface is presenting data at a rate of 8.192Mbit/s. When RxMUXEN = 1, 00 = Receive interface is taking data from the four LIU input channels 0 through 3 and byte-multiplexing into a 12.352MHz serial output on channel 0. The TxSYNC pulse remains "High" during the framing bit of each DS-1 frame. 01 = Receive interface is taking data from the four LIU input channels 0 through 3 and byte-multiplexing into a 16.384MHz serial output on channel 0. The TxSYNC pulse remains "High" during the framing bit of each DS-1 frame. 10 = Receive interface is taking data from the four LIU input channels 0 through 3 and byte-multiplexing into a 16.384MHz serial output on channel 0 (HMVIP Mode). The TxSYNC pulse remains "High" during the last two bits of the previous DS-1 frame and the first two bits of the current DS-1 frame. 11 = Receive interface is taking data from the four LIU input channels 0 through 3 and byte-multiplexing into a 16.384MHz serial output on channel 0 (H.100 Mode). The TxSYNC pulse remains "High" during the last bit of the previous DS-1 frame and the first bit of the current DS-1 frame. NOTE: Channels 4 through 7 are multiplexed into the serial output at channel 4.

TABLE 49: DS1 TEST REGISTER

Register 34 DS1 Test Register (DS1TR) 0x0123

BIT	FUNCTION	TYPE	DEFAULT	DESCRIPTION-OPERATION
7	PRBSTyp	R/W	0	PRBS Pattern Type 0 = The $(X^{15} + X^{14} + 1)$ PBRs Polynomial is generated. 1 = QRTS (Quasi-Random Test Signal) Pattern is generated.
6	ERRORIns	R/W	0	Error Insertion 0 to 1 transition will cause one output bit inverted

TABLE 49: DS1 TEST REGISTER

Register 34

DS1 Test Register (DS1TR)

0x0123

BIT	FUNCTION	TYPE	DEFAULT	DESCRIPTION-OPERATION
5	Reserved	-	-	Reserved
4	RxPRBSLock	R	0	Lock Status 0 = Rx PRBS has not Locked. 1 = Rx PRBS has locked to the input patterns.
3	RxPRBSEnb	R/W	0	Rx PRBS Generation Enable 0 = Receive PRBS checker is not enabled. 1 = Receive PRBS checker is enabled.
2	TxPRBSEnb	R/W	0	Tx PRBS Generation Enable 0 = Tx PRBS generator is not enabled. 1 = Tx PRBS generator is enabled.
1	RxDS1Bypass	R/W	0	Rx DS1 Framer Bypass 0 = Disabled 1 = Rx DS1 Framer Bypass Mode.
0	TxDS1Bypass	R/W	0	Tx DS1 Framer Bypass 0 = Disabled 1 = Tx DS1 Framer Bypass Mode.

TABLE 50: LOOPBACK CODE CONTROL REGISTER

Register 35

LOOPBACK CODE CONTROL REGISTER (LCCR)

0x0124

BIT	FUNCTION	TYPE	DEFAULT	DESCRIPTION-OPERATION
7-6	RXLBCDLEN[1:0]	R/W	0	Receive Loopback Code Activation Length Determines the receive loopback code activation length. 00 = 4-bit sequence 01 = 5-bit sequence 10 = 6-bit sequence 11 = 7-bit sequence
5-4	RXLBCDLEN[1:0]	R/W	0	Receive Loopback Code Deactivation Length Determines the receive loopback code deactivation length 00 = 4-bit sequence 01 = 5-bit sequence 10 = 6-bit sequence 11 = 7-bit sequence
3-2	TXLBCDLEN[1:0]	R/W	0	Transmit Loopback Code Length Determines transmit loopback code length. 00 = 4-bit sequence 01 = 5-bit sequence 10 = 6-bit sequence 11 = 7-bit sequence

TABLE 50: LOOPBACK CODE CONTROL REGISTER

Register 35

LOOPBACK CODE CONTROL REGISTER (LCCR)

0x0124

BIT	FUNCTION	TYPE	DEFAULT	DESCRIPTION-OPERATION
1	FRAMED	R	0	Framed Loopback Code Selects either framed or unframed loopback code operation. 0 = Unframed 1 = Framed
0	AUTOENB	R/W	0	Loopback Automatically Enables loopback automatically. 0 = Automatic loopback is disabled 1 = Automatic loopback is enabled

TABLE 51: TRANSMIT LOOPBACK CODER REGISTER

Register 36

Transmit Loopback Coder Register (TLCR)

0x0125

BIT	FUNCTION	TYPE	DEFAULT	DESCRIPTION-OPERATION
7-1	TXLBC[6:0]	R/W	1010101	Transmit Loopback Code Determines the transmit loopback coding sequence.
0	TXLBCENB	R/W	0	Transmit Loopback Code Enable Enables loopback code generation. 0 = Transmit loopback code is disabled. 1 = Transmit loopback code is enabled

TABLE 52: RECEIVE LOOPBACK ACTIVATION CODE REGISTER

Register 37

Receive Loopback Activation Code Register (RLACR)

0x0126

BIT	FUNCTION	TYPE	DEFAULT	DESCRIPTION-OPERATION
7-1	RXLBAC[6:0]	R/W	1010101	Receive activation loopback code Determines the receive activation loopback coding sequence.
0	RXLBACENB	R/W	0	Receive activation loopback code enable Enables receive loopback code activation detection. 0 = Receive loopback code activation detection is disabled. 1 = Receive loopback code activation detection is enabled

TABLE 53: RECEIVE LOOPBACK DEACTIVATION CODE REGISTER

Register 38

Receive Loopback Deactivation Code Register (RLDCR)

0x0127

BIT	FUNCTION	TYPE	DEFAULT	DESCRIPTION-OPERATION
7-1	RXLBDC[6:0]	R/W	1010101	Receive deactivation loopback code Determines the receive deactivation loopback coding sequence.
0	RXLBDCENB	R/W	0	Receive deactivation loopback code enable Enables receive loopback code deactivation detection. 0 = Receive loopback code deactivation detection is disabled. 1 = Receive loopback code deactivation detection is enabled

TABLE 54: TRANSMIT Sa SELECT REGISTER

Register 39

TRANSMIT Sa SELECT REGISTER (TSASR)

0x0130

BIT	FUNCTION	TYPE	DEFAULT	DESCRIPTION-OPERATION
7	TxSa8SEL	R/W	0	Sa8 bit Determines whether Sa8 is from serial input or register. 0 = Serial input. 1 = Sa8 register.
6	TxSa7SEL	R/W	0	Sa7 bit select Determines whether Sa7 is from serial input or register. 0 = Serial input. 1 = Sa7 register
5	TxSa6SEL	R/W	0	Sa6 bit select Determines whether Sa6 is from serial input or register. 0 = Serial input. 1 = Sa6 register
4	TxSa5SEL	R/W	0	Sa5 bit select Determines whether Sa5 is from serial input or register. 0 = Serial input. 1 = Sa5 register
3	TxSa4SEL	R/W	0	Sa4 bit select Determines whether Sa4 is from serial input or register. 0 = Serial input. 1 = Sa4 register
2	LB1ENB	R/W	0	Loopback 1 auto enable Local loopback is activated while the followings happened from the transmit serial input. Sa5 = 0 and Sa6 = 1111 occur for 8 consecutive times. A = 1
1	LB2ENB	R/W	0	Loopback 2 auto enable Local loopback is activated while the followings happened from the transmit serial input. Sa5 = 0 and Sa6 = 1010 occur for 8 consecutive times. A = 1
0	LBRENB	R/W	0	Loopback release enable Local loopback is released while the followings happened from the transmit serial input. Sa5 = 0 and Sa6 = 0000 occur for 8 consecutive times.

TABLE 55: TRANSMIT Sa AUTO CONTROL REGISTER 1

Register 40

TRANSMIT Sa AUTO CONTROL REGISTER 1 (TSACR1)

0x0131

BIT	FUNCTION	TYPE	DEFAULT	DESCRIPTION-OPERATION
7	LOSLFA_1_ENB	R/W	0	LOS/LFA 1 auto transmit
6	LOS_1_ENB	R/W	0	LOS 1 auto transmit

TABLE 55: TRANSMIT Sa AUTO CONTROL REGISTER 1

Register 40

TRANSMIT Sa AUTO CONTROL REGISTER 1 (TSACR1)

0x0131

BIT	FUNCTION	TYPE	DEFAULT	DESCRIPTION-OPERATION
5	LOSLFA_2_ENB	R/W	0	LOS/LFA 2 auto transmit
4	LOSLFA_3_ENB	R/W	0	LOS/LFA 3 auto transmit
3	LOSLFA_4_ENB	R/W	0	LOS/LFA 4 auto transmit
2	NOP_ENB	R/W	0	No power auto transmit
1	NOP_LOSLFA_ENB	R/W	0	No power and LOS/LFA auto transmit
0	LOS_2_ENB	R/W	0	LOS 3 auto transmit

The following table demonstrates the conditions on the receive side which trigger the actions while these bits are enabled.

TABLE 56: CONDITIONS ON RECEIVE SIDE WHEN TSACR1 BITS ARE ENABLED

CONDITIONS	ACTIONS - SENDING PATTERN			COMMENTS
	A	SA5	SA6	
LOSLFA_1_ENB: Loss of signal or Loss of frame alignment	X	1	0000	LOS/LFA at TE (FC2)
LOS_1_ENB: Loss of signal	1	1	1110	LOS (FC3)
LOSLFA_2_ENB: LOS or LFA	1	0	0000	LOS/LFA (FCL)
LOSLFA_3_ENB: LOS or LFA	0	1	1100	LOS/LFA (FC4)
LOSLFA_4_ENB: LOS or LFA	0	1	1110	LOS/LFA (FC3&FC4)
NOP_ENB: Loss of power	0	1	1000	Loss of power at NT1
NOP_LOSLFA_ENB: Loss of power and LOS or LFA	1	1	1000	Loss of power and LOS/LFA
LOS_2_ENB: LOS	AUXP pattern			LOS (FC1). Transmit AUXP pattern

TABLE 57: TRANSMIT Sa AUTO CONTROL REGISTER 2

Register 41

TRANSMIT Sa AUTO CONTROL REGISTER (TSACR2)

0x0132

BIT	FUNCTION	TYPE	DEFAULT	DESCRIPTION-OPERATION
7	AIS_1_ENB	R/W	0	AIS reception
6	AIS_2_ENB	R/W	0	AIS reception

TABLE 57: TRANSMIT Sa AUTO CONTROL REGISTER 2

Register 41

TRANSMIT Sa AUTO CONTROL REGISTER (TSACR2)

0x0132

BIT	FUNCTION	TYPE	DEFAULT	DESCRIPTION-OPERATION
5	Reserved	-	-	Reserved
4	Reserved	-	-	Reserved
3-2	CRCREP_ENB	R/W	0	CRC report
1	CRCDET_ENB	R/W	0	CRC detection
0	CRCREC/DET_ENB	R/W	0	CRC report and detect

The following table demonstrates the conditions on receive side which trigger the actions while these bit are enabled.

TABLE 58: CONDITIONS ON RECEIVE SIDE WHEN TSACR1 BITS ENABLED

CONDITIONS	ACTIONS - SENDING PATTERN FOR			
	A	Sa5	Sa6	E
AIS_1_ENB	1	1	1111	X
AIS_2_ENB	0	1	1111	x
CRCREP_ENB = 01, CRC reported (E = 0)	0	1	0000	0
CRCREP_ENB = 10, CRC reported	0	0	0000	0
CRCREP_ENB = 11, CRC reported	0	1	0001	1
CRCDET_ENB	0	1	0010	1
CRCDET/REP_ENB	0	1	0011	1

TABLE 59: TRANSMIT Sa4 REGISTER

Register 42

TRANSMIT Sa4 REGISTER (TSA4R)

0x0133

BIT	FUNCTION	TYPE	DEFAULT	DESCRIPTION-OPERATION
7-0	TxSa4[7:0]	R/W	11111111	Sa4 The content of this register sources the transmit Sa4 bits while TxSa4ENB (register 0x010Ah) is 1 and TxSa4SEL (register 0x0130h) is 1. Bit 7 is transmitted in frame 2 of the CRC-4 multiframe, bit 6 is in frame 4, etc.

TABLE 60: TRANSMIT Sa5 REGISTER

Register 43

TRANSMIT Sa5 REGISTER (TSA5R)

0x0134

BIT	FUNCTION	TYPE	DEFAULT	DESCRIPTION-OPERATION
7-0	TxSa5[7:0]	R/W	11111111	Sa5 The content of this register sources the transmit Sa5 bits while TxSa5ENB (register 0x010Ah) is 1 and TxSa5SEL (register 0x0130h) is 1. Bit 7 is transmitted in frame 2 of the CRC-4 multiframe, bit 6 is in frame 4, etc.

TABLE 61: TRANSMIT Sa6 REGISTER

Register 44

TRANSMIT Sa6 REGISTER (TSA6R)

0x0135

BIT	FUNCTION	TYPE	DEFAULT	DESCRIPTION-OPERATION
7-0	TxSa6[7:0]	R/W	11111111	Sa6 The content of this register sources the transmit Sa6 bits while TxSa6ENB (register 0x010Ah) is 1 and TxSa6SEL (register 0x0130h) is 1. Bit 7 is transmitted in frame 2 of the CRC-4 multiframe, bit 6 is in frame 4, etc.

TABLE 62: TRANSMIT Sa7 REGISTER

Register 45

TRANSMIT Sa7 REGISTER (TSA7R)

0x0136

BIT	FUNCTION	TYPE	DEFAULT	DESCRIPTION-OPERATION
7-0	TxSa7[7:0]	R/W	11111111	Sa7 The content of this register sources the transmit Sa7 bits while TxSa7ENB (register 0x010Ah) is 1 and TxSa7SEL (register 0x0130h) is 1. Bit 7 is transmitted in frame 2 of the CRC-4 multiframe, bit 6 is in frame 4, etc.

TABLE 63: TRANSMIT Sa8 REGISTER

Register 46

TRANSMIT Sa8 REGISTER (TSA8R)

0x0137

BIT	FUNCTION	TYPE	DEFAULT	DESCRIPTION-OPERATION
7-0	TxSa8[7:0]	R/W	11111111	Sa8 The content of this register sources the transmit Sa8 bits while TxSa8ENB (register 0x010Ah) is 1 and TxSa8SEL (register 0x0130h) is 1. Bit 7 is transmitted in frame 2 of the CRC-4 multiframe, bit 6 is in frame 4, etc.

TABLE 64: RECEIVE SA4 REGISTER

Register 47 RECEIVE SA4 REGISTER (RSA4R) 0x013B

BIT	FUNCTION	TYPE	DEFAULT	DESCRIPTION-OPERATION
7-0	RxSa4[7:0]	RO	11111111	Sa4 The content of this register stores the received Sa4 bits if RxSa4ENB (register 0x010Ch) is 1. Bit 7 is received in frame 2 of the CRC-4 multiframe, bit 6 is in frame 4, etc.

TABLE 65: RECEIVE SA5 REGISTER

Register 48 RECEIVE SA5 REGISTER (RSA5R) 0x013C

BIT	FUNCTION	TYPE	DEFAULT	DESCRIPTION-OPERATION
7-0	RxSa5[7:0]	RO	11111111	Sa5 The content of this register stores the received Sa5 bits if RxSa5ENB (register 0x010Ch) is 1. Bit 7 is received in frame 2 of the CRC-4 multiframe, bit 6 is in frame 4, etc.

TABLE 66: RECEIVE SA6 REGISTER

REGISTER 49 RECEIVE SA6 REGISTER (RSA6R) 0x013D

BIT	FUNCTION	TYPE	DEFAULT	DESCRIPTION-OPERATION
7-0	RxSa6[7:0]	RO	11111111	Sa6 The content of this register stores the received Sa6 bits if RxSa6ENB (register 0x010Ch) is 1. Bit 7 is received in frame 2 of the CRC-4 multiframe, bit 6 is in frame 4, etc.

TABLE 67: RECEIVE SA7 REGISTER

REGISTER 50 RECEIVE SA7 REGISTER (RSA7R) 0x013E

BIT	FUNCTION	TYPE	DEFAULT	DESCRIPTION-OPERATION
7-0	RxSa7[7:0]	RO	11111111	Sa7 The content of this register stores the received Sa7 bits if RxSa7ENB (register 0x010Ch) is 1. Bit 7 is received in frame 2 of the CRC-4 multiframe, bit 6 is in frame 4, etc.

TABLE 68: RECEIVE SA8 REGISTER

REGISTER 51

RECEIVE SA8 REGISTER (RSA8R)

0x013F

BIT	FUNCTION	TYPE	DEFAULT	DESCRIPTION-OPERATION
7-0	RxSa8[7:0]	RO	11111111	<p>Sa8</p> <p>The content of this register stores the received Sa8 bits if RxSa8ENB (register 0x010Ch) is 1.</p> <p>Bit 7 is received in frame 2 of the CRC-4 multiframe, bit 6 is in frame 4, etc.</p>

TABLE 69: DATA LINK CONTROL REGISTER

REGISTER 52

DATA LINK CONTROL REGISTER 2 (DLCR2)

HEX ADDRESS: 0x0143

BIT	FUNCTION	TYPE	DEFAULT	DESCRIPTION-OPERATION
7	SLC@96	R/W	0	<p>SLC@96 Enable, 6 bit for ESF</p> <p>If SLC@96 framing is selected, setting this bit high will enable SLC@96 data link transmission; Otherwise, the regular SF framing bits are transmitted.</p> <p>In ESF framing mode, setting this bit high will cause facility data link to transmit/receive SLC@96-like message.</p>
6	MOSA	R/W	0	<p>MOS Abort Enable/Disable Select</p> <p>This Read/Write bit-field is used to configure the transmit HDLC2 controller to automatically transmit an abort sequence anytime it transitions from the MOS mode to the BOS mode.</p> <p>0 = Transmit HDLC2 Controller inserts an MOS abort sequence if the MOS message is interrupted</p> <p>1 = Prevents Transmit HDLC2 Controller from inserting an MOS abort sequence.</p>
5	Rx_FCS_DIS	R/W	0	<p>Receive FCS Verification Disable</p> <p>Enables/Disables Receive HDLC2 Controller's computation and verification of the FCS value in the incoming LAPD message frame</p> <p>0 = Verifies FCS value of each MOS frame.</p> <p>1 = Does not verify FCS value of each MOS frame.</p>
4	AutoRx	R/W	0	<p>Auto Receive LAPD Message</p> <p>Configures the Rx HDLC2 Controller to discard any incoming LAPD Message frame that exactly match which is currently stored in the Rx HDLC2 buffer.</p> <p>0 = Disabled</p> <p>1 = Enables this feature.</p>
3	Tx_ABORT	R/W	0	<p>Transmit ABORT</p> <p>Configures the Tx HDLC2 Controller to transmit an ABORT sequence (string of 7 or more consecutive 1's) to the Remote terminal.</p> <p>0 = Tx HDLC2 Controller operates normally</p> <p>1 = Tx HDLC2 Controller inserts an ABORT sequence into the data link channel.</p>

TABLE 69: DATA LINK CONTROL REGISTER
REGISTER 52
DATA LINK CONTROL REGISTER 2 (DLCR2)
HEX ADDRESS: 0x0143

BIT	FUNCTION	TYPE	DEFAULT	DESCRIPTION-OPERATION
2	Tx_IDLE	R/W	0	Transmit Idle (Flag Sequence Byte) Configures the Tx HDLC2 controller to transmit a string of Flag Sequence octets (0X7E) in the data link channel to the Remote terminal. 0 = Tx HDLC2 Controller resumes transmitting data to the Remote terminal 1 = Tx HDLC2 Controller transmits a string of Flag Sequence bytes. NOTE: This bit-field is ignored if the Tx HDLC2 controller is operating in the BOS Mode - bit-field 0(MOS/BOS) within this register is set to 0.
1	Tx_FCS_EN	R/W	0	Transmit LAPD Message with FCS Configure HDLC2 Controller to include/not include FCS octets in the outbound LAPD message frames. 0 = Does not include FCS octets into the outbound LAPD message frame. 1 = Inserts FCS octets into the outbound LAPD message frame. NOTE: This bit-field is ignored if the transmit HDLC2 controller has been configured to operate in the BOS mode.
0	MOS/BOS	R/W	0	Message Oriented Signaling/Bit Oriented Signaling Select Specifies whether the TxRx HDLC2 Controller will be transmitting and receiving LAPD message frames (MOS) or Bit Oriented Signal (BOS) messages. 0 = Tx/Rx HDLC2 Controller transmits and receives BOS messages. 1 = Tx/Rx HDLC2 Controller transmits and receives MOS messages.

TABLE 70: TRANSMIT DATA LINK BYTE COUNT REGISTER
REGISTER 53
TRANSMIT DATA LINK BYTE COUNT REGISTER 2 (TDLBCR2)
HEX ADDRESS: 0x0144

BIT	FUNCTION	TYPE	DEFAULT	DESCRIPTION-OPERATION
7	BUFAVAL//BUFSEL	R/W	0	Transmit HDLC2 Buffer Available/Buffer Select Specifies which of the two Tx HDLC2 Buffers that the Tx HDLC2 controller should read from to generate the next outbound HDLC2 message. 0 = transmits message data residing in Tx HDLC2 Buffer 0. 1 = transmits message data residing in Tx HDLC2 buffer 1. NOTE: If one of these Tx HDLC2 buffers contain a message which has yet to be completely read-in and processed for transmission by the Tx HDLC2 controller, then this bit-field will automatically reflect the value corresponding to the available buffer. Changing this bit-field to the in-use buffer is not permitted.

TABLE 70: TRANSMIT DATA LINK BYTE COUNT REGISTER

REGISTER 53

TRANSMIT DATA LINK BYTE COUNT REGISTER 2 (TDLBCR2)

HEX ADDRESS: 0x0144

BIT	FUNCTION	TYPE	DEFAULT	DESCRIPTION-OPERATION
6	TDLBC6	R/W	0	Transmit HDLC2 Message - Byte Count
5	TDLBC5	R/W	0	Depends on whether an MOS or BOS message is being transmitted to the Remote Terminal Equipment If BOS message is being transmitted: These bit fields contain the number of repetitions the BOS message must be transmitted before the Tx HDLC2 controller generates the TxEOT interrupt and halts transmission. If these fields are set to 00000000, then the BOS message will be transmitted for an indefinite number of times. If MOS message is being transmitted: These bit fields contain the length, in number of octets, of the message to be transmitted.
4	TDLBC4	R/W	0	
3	TDLBC3	R/W	0	
2	TDLBC2	R/W	0	
1	TDLBC1	R/W	0	
0	TDLBC0	R/W	0	

TABLE 71: RECEIVE DATA LINK BYTE COUNT REGISTER

REGISTER 54

RECEIVE DATA LINK BYTE COUNT REGISTER 2 (RDLBCR2)

HEX ADDRESS: 0x0145

BIT	FUNCTION	TYPE	DEFAULT	DESCRIPTION-OPERATION
7	RBUFPTR	R/W	0	Receive HDLC2 Buffer-Pointer Identifies which RxHDLC2 buffer contains the newly received HDLC2 message. 0 = HDLC2 message is stored in Rx HDLC2 Buffer 0. 1 = HDLC2 message is stored in Rx HDLC2 Buffer 1.
6	RDLBC6	R/W	0	Receive HDLC Message - byte count In MOS Mode These seven bit-fields contain the size in bytes of the HDLC2 message that has been extracted and written into the Rx HDLC2 buffer. In BOS Mode These bits should be set to the value of the message repetitions before each receive interrupt. If they are set to "0", no RxEOT interrupt will be generated.
5	RDLBC5	R/W	0	
4	RDLBC4	R/W	0	
3	RDLBC3	R/W	0	
2	RDLBC2	R/W	0	
1	RDLBC1	R/W	0	
0	RDLBC0	R/W	0	

TABLE 72: DATA LINK CONTROL REGISTER
REGISTER 55
DATA LINK CONTROL REGISTER 3 (DLCR3)
HEX ADDRESS: 0x0153

BIT	FUNCTION	TYPE	DEFAULT	DESCRIPTION-OPERATION
7	SLC@96	R/W	0	<p>SLC@96 Enable, 6 bit for ESF</p> <p>If SLC@96 framing is selected, setting this bit high will enable SLC@96 data link transmission; Otherwise, the regular SF framing bits are transmitted.</p> <p>In ESF framing mode, setting this bit high will cause facility data link to transmit/receive SLC@96-like message.</p>
6	MOSA	R/W	0	<p>MOS Abort Enable/Disable Select</p> <p>This Read/Write bit-field is used to configure the transmit HDLC3 controller to automatically transmit an abort sequence anytime it transitions from the MOS mode to the BOS mode.</p> <p>0 = Transmit HDLC3 Controller inserts an MOS abort sequence if the MOS message is interrupted</p> <p>1 = Prevents Transmit HDLC3 Controller from inserting an MOS abort sequence.</p>
5	Rx_FCS_DIS	R/W	0	<p>Receive FCS Verification Disable</p> <p>Enables/Disables Receive HDLC3 Controller's computation and verification of the FCS value in the incoming LAPD message frame</p> <p>0 = Verifies FCS value of each MOS frame.</p> <p>1 = Does not verify FCS value of each MOS frame.</p>
4	AutoRx	R/W	0	<p>Auto Receive LAPD Message</p> <p>Configures the Rx HDLC3 Controller to discard any incoming LAPD Message frame that exactly match which is currently stored in the Rx HDLC3 buffer.</p> <p>0 = Disabled</p> <p>1 = Enables this feature.</p>
3	Tx_ABORT	R/W	0	<p>Transmit ABORT</p> <p>Configures the Tx HDLC3 Controller to transmit an ABORT sequence (string of 7 or more consecutive 1's) to the Remote terminal.</p> <p>0 = Tx HDLC3 Controller operates normally</p> <p>1 = Tx HDLC3 Controller inserts an ABORT sequence into the data link channel.</p>
2	Tx_IDLE	R/W	0	<p>Transmit Idle (Flag Sequence Byte)</p> <p>Configures the Tx HDLC3 controller to transmit a string of Flag Sequence octets (0X7E) in the data link channel to the Remote terminal.</p> <p>0 = Tx HDLC3 Controller resumes transmitting data to the Remote terminal</p> <p>1 = Tx HDLC3 Controller transmits a string of Flag Sequence bytes.</p> <p>NOTE: This bit-field is ignored if the Tx HDLC3 controller is operating in the BOS Mode - bit-field 0(MOS/BOS) within this register is set to 0.</p>

TABLE 72: DATA LINK CONTROL REGISTER

REGISTER 55

DATA LINK CONTROL REGISTER 3 (DLCR3)

HEX ADDRESS: 0x0153

BIT	FUNCTION	TYPE	DEFAULT	DESCRIPTION-OPERATION
1	Tx_FCS_EN	R/W	0	Transmit LAPD Message with FCS Configure HDLC3 Controller to include/not include FCS octets in the outbound LAPD message frames. 0 = Does not include FCS octets into the outbound LAPD message frame. 1 = Inserts FCS octets into the outbound LAPD message frame. NOTE: This bit-field is ignored if the transmit HDLC3 controller has been configured to operate in the BOS mode.
0	MOS/BOS	R/W	0	Message Oriented Signaling/Bit Oriented Signaling Select Specifies whether the TxRx HDLC3 Controller will be transmitting and receiving LAPD message frames (MOS) or Bit Oriented Signal (BOS) messages. 0 = Tx/Rx HDLC3 Controller transmits and receives BOS messages. 1 = Tx/Rx HDLC3 Controller transmits and receives MOS messages.

TABLE 73: TRANSMIT DATA LINK BYTE COUNT REGISTER

REGISTER 56

TRANSMIT DATA LINK BYTE COUNT REGISTER 3 (TDLBCR3)

HEX ADDRESS: 0x0154

BIT	FUNCTION	TYPE	DEFAULT	DESCRIPTION-OPERATION
7	BUFAVAL//BUFSEL	R/W	0	Transmit HDLC3 Buffer Available/Buffer Select Specifies which of the two Tx HDLC3 Buffers that the Tx HDLC3 controller should read from to generate the next outbound HDLC3 message. 0 = transmits message data residing in Tx HDLC3 Buffer 0. 1 = transmits message data residing in Tx HDLC3 buffer 1. NOTE: If one of these Tx HDLC3 buffers contain a message which has yet to be completely read-in and processed for transmission by the Tx HDLC3 controller, then this bit-field will automatically reflect the value corresponding to the available buffer. Changing this bit-field to the in-use buffer is not permitted.
6	TDLBC6	R/W	0	Transmit HDLC3 Message - Byte Count
5	TDLBC5	R/W	0	Depends on whether an MOS or BOS message is being transmitted to the Remote Terminal Equipment
4	TDLBC4	R/W	0	If BOS message is being transmitted: These bit fields contain the number of repetitions the BOS message must be transmitted before the Tx HDLC3 controller generates the TxEOt interrupt and halts transmission. If these fields are set to 00000000, then the BOS message will be transmitted for an indefinite number of times.
3	TDLBC3	R/W	0	
2	TDLBC2	R/W	0	
1	TDLBC1	R/W	0	
0	TDLBC0	R/W	0	If MOS message is being transmitted: These bit fields contain the length, in number of octets, of the message to be transmitted.

TABLE 74: RECEIVE DATA LINK BYTE COUNT REGISTER

REGISTER 57

RECEIVE DATA LINK BYTE COUNT REGISTER 3 (RDLBCR3)

HEX ADDRESS: 0x0155

BIT	FUNCTION	TYPE	DEFAULT	DESCRIPTION-OPERATION
7	RBUFPTR	R/W	0	Receive HDLC3 Buffer-Pointer Identifies which RxHDLC3 buffer contains the newly received HDLC3 message. 0 = HDLC3 message is stored in Rx HDLC3 Buffer 0. 1 = HDLC3 message is stored in Rx HDLC3 Buffer 1.
6	RDLBC6	R/W	0	Receive HDLC Message - byte count In MOS Mode These seven bit-fields contain the size in bytes of the HDLC3 message that has been extracted and written into the Rx HDLC3 buffer. In BOS Mode These bits should be set to the value of the message repetitions before each receive interrupt. If they are set to "0", no RxEOT interrupt will be generated.
5	RDLBC5	R/W	0	
4	RDLBC4	R/W	0	
3	RDLBC3	R/W	0	
2	RDLBC2	R/W	0	
1	RDLBC1	R/W	0	
0	RDLBC0	R/W	0	

TABLE 75: DEVICE ID REGISTER

REGISTER 58

DEVICE ID REGISTER (DEVID)

0x01FE

BIT	FUNCTION	TYPE	DEFAULT	DESCRIPTION-OPERATION
7-0	DEVID[7:0]	RO	00110111	DEVID This register is used to identify the XRT86L30 Framer/LIU. The value of this register is 0x37h.

TABLE 76: REVISION ID REGISTER

REGISTER 59

REVISION ID REGISTER (REVID)

0x01FF

BIT	FUNCTION	TYPE	DEFAULT	DESCRIPTION-OPERATION
7-0	REVID[7:0]	RO	00000001	REVID This register is used to identify the revision number of the XRT86L30. The value of this register for revision A is 0x01h.

TABLE 77: TRANSMIT CHANNEL CONTROL REGISTER 0 TO 31 E1 MODE

REGISTER 60-91 E1

TRANSMIT CHANNEL CONTROL REGISTER 0-31 (TCCR 0-31)

HEX ADDRESS: 0x0300 TO 0x031F

BIT	MODE	FUNCTION	TYPE	DEFAULT	DESCRIPTION-OPERATION
7-6	E1	LAPDcntl	R/W	10	LAPD Control These bits select which LAPD controller is to be activated. 00 = LAPD1 01 = LAPD2 10 = TxDE[1:0] will determine the data source for the D/E Time Slots 11 = LAPD3

TABLE 78: TRANSMIT CHANNEL CONTROL REGISTER 0 TO 31 T1 MODE

REGISTER 60-91 T1 TRANSMIT CHANNEL CONTROL REGISTER 0-23 (TCCR 0-23) HEX ADDRESS: 0x0300 TO 0x0317

BIT	FUNCTION	TYPE	DEFAULT	DESCRIPTION-OPERATION
7-6	LAPDcntl	R/W	10	LAPD Control These bits select which LAPD controller is to be activated. 00 = LAPD1 01 = LAPD2 10 = TxDE[1:0] will determine the data source for the D/E Time Slots 11 = LAPD3

TABLE 79: TRANSMIT USER CODE REGISTER 0 TO 31

REGISTER 92-123 T1/E1 TRANSMIT USER CODE REGISTER 0 (UCR 0-31) HEX ADDRESS: 0x0320 TO 0x033F

BIT	FUNCTION	TYPE	DEFAULT	DESCRIPTION-OPERATION
7-0	TUCR[7:0]	R/W	0	Programmable User code.

TABLE 80: TRANSMIT SIGNALING CONTROL REGISTER X - E1 MODE

REGISTER 124-155 - E1 TRANSMIT SIGNALING CONTROL REGISTER X (TSCR 0-31) HEX ADDRESS: 0x0340 TO 0x035F

BIT	FUNCTION	TYPE	DEFAULT	DESCRIPTION-OPERATION
7	A (x)	R/W	0 (1)	Signaling bit A or x bit A,B,C,D: These are programmable signaling information. Note: Time slot 16 of frame 0 is controlled by TSCR0 (for 0 bits) and TSCR16 (for xyxx bits).
6	B (y)	R/W	0 (0)	Signaling bit B or y bit
5	C (x)	R/W	0 (1)	Signaling bit C or x bit
4	D (x)	R/W	0 (1)	Signaling bit D or x bit
3	Reserved	-	-	Reserved
2	Reserved	-	-	Reserved
1	TxSIGSRC[1]	R/W	0	Channel signaling control
0	TxSIGSRC[0]	R/W	0	These bits determine the selection of signaling conditioning. 00 = No signaling data is inserted into input PCM data (passthrough). 01 = Signaling data is inserted from TSCRs. 10 = Signaling data is inserted from TxOH input while TxMUXEN=0 and TxIMODE[1:0]=00, otherwise is inserted from TxSIG input. 11 = No signaling. For xyxx bits only, x's are from TSCR and y is the alarm condition.

TABLE 81: TRANSMIT SIGNALING CONTROL REGISTER X - T1 MODE

REGISTER 124-155 - T1 TRANSMIT SIGNALING CONTROL REGISTER X (TSCR) (0-23) HEX ADDRESS: 0x0340 TO 0x035F

BIT	FUNCTION	TYPE	DEFAULT	DESCRIPTION-OPERATION
7	A (x)	R/W	0 (1)	Signaling bit A A,B,C,D: These are programmable signaling information.
6	B (y)	R/W	0 (0)	Signaling bit B
5	C (x)	R/W	0 (1)	Signaling bit C
4	D (x)	R/W	0 (1)	Signaling bit D
3	Reserved	-	-	Reserved
2	Rob_Enb	R/W	0	Robbed-bit signaling enable This bit enables Robbed-bit signaling transmission. 0 = Robbed-bit is disabled. 1 = Robbed-bit is enabled
1	TxSIGSRC[1]	R/W	0	Channel signaling control
0	TxSIGSRC[0]	R/W	0	These bits determine the selection of signaling conditioning. 00 = No signaling data is inserted into input PCM data. 01 = Signaling data is inserted from TSCRs. 10 = Signaling data is inserted from TxSig input. 11 = No signaling.

TABLE 82: RECEIVE CHANNEL CONTROL REGISTER X (RCCR 0-31) - E1 MODE

REGISTER 156-187 E1 RECEIVE CHANNEL CONTROL REGISTER X (RCCR 0-31) HEX ADDRESS: 0x0360 TO 0x037F

BIT	FUNCTION	TYPE	DEFAULT	DESCRIPTION-OPERATION
7-6	LAPDcntl	R/W	10	LAPD Control These bits select which LAPD controller is to be activated. 00 = LAPD1 01 = LAPD2 10 = RxDE[1:0] will determine the data source for the D/E Time Slots 11 = LAPD3
5-4	Reserved	-	-	Reserved

TABLE 82: RECEIVE CHANNEL CONTROL REGISTER X (RCCR 0-31) - E1 MODE

REGISTER 156-187 E1 RECEIVE CHANNEL CONTROL REGISTER X (RCCR 0-31) HEX ADDRESS: 0x0360 TO 0x037F

BIT	FUNCTION	TYPE	DEFAULT	DESCRIPTION-OPERATION
3	RxCOND[3]	R/W	0	Selects Data Conditioning These bits determines the type of data condition applying to input PCM data. 0x0 = The input PCM data is unchanged. 0x1 = All 8 bits of the PCM channel data are inverted. 0x2 = The even bits of input data are inverted. 0x3 = The odd bits of input data are inverted. 0x4 = Data in User Code Register shown in Table 3-27 replaces the input data. 0x5 = BUSY FF code (0xFF) replaces the input data. 0x6 = BUSY 0Vcode (0xD5) replaces the input data. 0x7 = BUSY TS (111#_####) replaces the input data; ##### is Timeslot number. 0x8 = BUSY 00 (0x00) replaces the input data. 0x9 = The A-law digital milliwatt pattern replaces the input data. 0xA = The m-law digital milliwatt pattern replaces the input data. 0xB = The MSB (bit 1) of input data is inverted. 0xC = All input data except MSB is inverted. 0xD = PRBS, $QRTS/X^{15} + X^{14} + 1$. 0xE = The input PCM data bit are unchanged. 0xF = This is a D/E time slots. See receive Signaling data link select register 12. (RS&DLSR)
2	RxCOND[2]	R/W	0	
1	RxCOND[1]	R/W	0	
0	RxCOND[0]	R/W	0	

TABLE 83: RECEIVE CHANNEL CONTROL REGISTER X (RCCR 0-23) - T1 MODE

REGISTER 156-187 - T1 RECEIVE CHANNEL CONTROL REGISTER X (RCCR 0-23) HEX ADDRESS: 0x0360 TO 0x037F

BIT	FUNCTION	TYPE	DEFAULT	DESCRIPTION-OPERATION
7-6	LAPDcntl	R/W	10	LAPD Control These bits select which LAPD controller is to be activated. 00 = LAPD1 01 = LAPD2 10 = RxDE[1:0] will determine the data source for the D/E Time Slots 11 = LAPD3
5	RxZERO[1]	R/W	0	Selects Type of Zero Suppression
4	RxZERO[0]	R/W	0	These bits select the zero code suppression used. 00 = No zero code suppression is used. 01 = AT&T bit 7 stuffing is used. 10 = GTE zero code suppression is used. Bit 8 is stuffed in non-signaling frame. Otherwise, bit 7 is stuffed in signaling frame if the signaling bit is zero. 11 = DDS zero code suppression is applied.

TABLE 83: RECEIVE CHANNEL CONTROL REGISTER X (RCCR 0-23) - T1 MODE

REGISTER 156-187 - T1 RECEIVE CHANNEL CONTROL REGISTER X (RCCR 0-23) HEX ADDRESS: 0x0360 TO 0x037F

BIT	FUNCTION	TYPE	DEFAULT	DESCRIPTION-OPERATION
3	RxCOND[3]	R/W	0	Selects Data Conditioning These bits determines the type of data condition applying to input PCM data. 0x0 = The input PCM data is unchanged. 0x1 = All 8 bits of the PCM channel data are inverted. 0x2 = The even bits of input data are inverted. 0x3 = The odd bits of input data are inverted. 0x4 = Data in User (IDLE) Code Register (Table 3?49) replaces the input data for transmission. 0x5 = BUSY code (0x7F) replaces the input data for transmission. 0x6 = VACANT code (0xFF) replaces the input data for transmission. 0x7 = BUSY TS (111#_####) replaces the input data for transmission; ##### is Timeslot number. 0x8 = MOOF (0x1A) replaces the input data for transmission. 0x9 = The A-law digital milliwatt pattern replaces the input data. 0xA = The m-law digital milliwatt pattern replaces the input data. 0xB = The MSB (bit 1) of input data is inverted. 0xC = All input data except MSB is inverted. 0xD = PRBS, $QRTS/X^{15} + X^{14} + 1$. 0xE = The input PCM data bit are unchanged. 0xF = This is a D/E time slots. See receive signaling data link select register 12. (RS&DLSR)
2	RxCOND[2]	R/W	0	
1	RxCOND[1]	R/W	0	
0	RxCOND[0]	R/W	0	

TABLE 84: RECEIVE USER CODE REGISTER X (RUCR 0-31)

REGISTER 188-219 T1/E1 RECEIVE USER CODE REGISTER X (RUCR 0-31) HEX ADDRESS: 0x0380 TO 0x039F

BIT	FUNCTION	TYPE	DEFAULT	DESCRIPTION-OPERATION
7	RxUSER[7]	R/W	1	Programmable USER code
6	RxUSER[6]	R/W	1	
5	RxUSER[5]	R/W	1	
4	RxUSER[4]	R/W	1	
3	RxUSER[3]	R/W	1	
2	RxUSER[2]	R/W	1	
1	RxUSER[1]	R/W	1	
0	RxUSER[0]	R/W	1	

TABLE 85: RECEIVE SIGNALING CONTROL REGISTER X (RSCR) (0-31)

REGISTER 220-251 T1/E1 RECEIVE SIGNALING CONTROL REGISTER X (RSCR) (0-31) HEX ADDRESS: 0x03A0 TO 0x03BF

BIT	FUNCTION	TYPE	DEFAULT	DESCRIPTION-OPERATION
6	SIGC_ENB	R/W	0	Signaling substitution enable This bit enables signaling substitution. 0 = Substitution is disabled. 1 = Substitution is enabled.
5	OH_ENB	R/W	0	Signaling OH interface output enable This bit enables outputting signaling through overhead interface. The information in receive signaling array registers is output to receive overhead interface. 0 = Output is disabled. 1 = Output is enabled.
4	DEB_ENB	R/W	0	Per-channel debounce enable This bit enables signaling debounce feature. 0 = Debounce is disabled. 1 = Debounce is enabled.
3	RxSIGC[1]	R/W	0	Signaling conditioning These bits control per-channel signaling substitution. 00 = Substitutes all signaling bits with one. 01 = Enables 16-code (SIG16-A,B,C,D) signaling substitution. 10 = Enables 4-code (SIG4-A,B) signaling substitution. 11 = Enables 2-code (SIG2-A) signaling substitution.
2	RxSIGC[0]	R/W	0	
1	RxSIGE[1]	R/W	0	Signaling extraction. These bits determines the extracted signaling coding. 00 = No signaling is extracted. 01 = Extracts 16-code signaling. 10 = Extracts 4-code signaling. 11 = Extracts 2-code signaling.
0	RxSIGE[0]	R/W	0	

TABLE 86: RECEIVE SUBSTITUTION SIGNALING REGISTER (RSSR) E1 MODE

REGISTER 252-283 E1 MODE RECEIVE SUBSTITUTION SIGNALING REGISTER (RSSR 0-31) HEX ADDRESS 0x03C0 TO 0x03DF

BIT	FUNCTION	TYPE	DEFAULT	DESCRIPTION-OPERATION
6	SIG2-A	R/W	0	2-code signaling A
5	SIG4-B	R/W	0	4-code signaling B
4	SIG4-A	R/W	0	4-code signaling A
3	SIG16-D	R/W	0	16-code signaling D
2	SIG16-C	R/W	0	16-code signaling C
1	SIG16-B	R/W	0	16-code signaling B
0	SIG16-A	R/W	0	16-code signaling A

TABLE 87: RECEIVE SUBSTITUTION SIGNALING REGISTER (RSSR) T1 MODE

REGISTER 252-283 - T1 RECEIVE SUBSTITUTION SIGNALING REGISTER (RSSR 0-23) HEX ADDRESS: 0x03C0 TO 0x03DF

BIT	FUNCTION	TYPE	DEFAULT	DESCRIPTION-OPERATION
7-4	Reserved	-	-	Reserved
3	SIG16-A, 4-A, 2-A	R/W	0	16-code signaling A 4-code signaling A 2-code signaling A
2	SIG16-B, 4-B, 2-A	R/W	0	16-code signaling B 4-code signaling B 2-code signaling A
1	SIG16-C, 4-A, 2-A	R/W	0	16-code signaling C 4-code signaling A 2-code signaling A
0	SIG16-D, 4-B, 2-A	R/W	0	16-code signaling D 4-code signaling B 2-code signaling A

TABLE 88: RECEIVE SIGNALING ARRAY REGISTER 0 TO 31

REGISTER 284-315 RECEIVE SIGNALING ARRAY REGISTER (RSAR 0-31) HEX ADDRESS: 0x0500 TO 0x051F

BIT	FUNCTION	TYPE	DEFAULT	DESCRIPTION-OPERATION
7-4	Reserved	-	-	Reserved
3	A	R/W	0	Reflects the most recently received signaling value (A,B,C,D) associated with timeslot 0 to 31. <i>NOTE: The content of this register only has meaning when the framer is using Channel Associated Signaling.</i>
2	B	R/W	0	
1	C	R/W	0	
0	D	R/W	0	

TABLE 89: LAPD BUFFER 0 CONTROL REGISTER

REGISTER 316-411 LAPD BUFFER 0 CONTROL REGISTER (LAPDBCRO) HEX ADDRESS: 0x0600 TO 0x0660

BIT	FUNCTION	TYPE	DEFAULT	DESCRIPTION-OPERATION
7-0	LAPD Buffer 0	R/W	0	LAPD Buffer 0 (96-Bytes) This register is used to transmit and receive LAPD messages within buffer 0 of the HDLC controller chosen in the LAPD Select Register (0x011B). When writing to buffer 0, the message is inserted into the outgoing LAPD frame and the data cannot be retrieved. After detecting the Rx end of transfer interrupt (RxEOT), the extracted LAPD message is available to be read. <i>NOTE: When writing or reading from Buffer 0, the register is automatically incremented such that 0x0600 can be written to or read from continuously.</i>

TABLE 90: LAPD BUFFER 1 CONTROL REGISTER

REGISTER 412-507 LAPD BUFFER 0 CONTROL REGISTER (LAPDBCR1) HEX ADDRESS: 0x0700 TO 0x0760

BIT	FUNCTION	TYPE	DEFAULT	DESCRIPTION-OPERATION
7-0	LAPD Buffer 1	R/W	0	<p>LAPD Buffer 1 (96-Bytes)</p> <p>This register is used to transmit and receive LAPD messages within buffer 1 of the HDLC controller chosen in the LAPD Select Register (0x011B). When writing to buffer 1, the message is inserted into the outgoing LAPD frame and the data cannot be retrieved. After detecting the Rx end of transfer interrupt, the extracted LAPD message is available to be read.</p> <p><i>NOTE: When writing or reading from Buffer 1, the register is automatically incremented such that 0x0700 can be written to or read from continuously.</i></p>

TABLE 91: PMON T1/E1 RECEIVE LINE CODE (BIPOLAR) VIOLATION COUNTER

REGISTER 508 PMON RECEIVE LINE CODE (BIPOLAR) VIOLATION COUNTER MSB (RLCVCU) HEX ADDRESS: 0x0900

BIT	FUNCTION	TYPE	DEFAULT	DESCRIPTION-OPERATION
7	RLCVC[15]	RUR	0	These eight bits represent the MSB for the 16-bit Line Code Violation counter.
6	RLCVC[14]	RUR	0	
5	RLCVC[13]	RUR	0	
4	RLCVC[12]	RUR	0	
3	RLCVC[11]	RUR	0	
2	RLCVC[10]	RUR	0	
1	RLCVC[9]	RUR	0	
0	RLCVC[8]	RUR	0	

TABLE 92: PMON T1/E1 RECEIVE LINE CODE (BIPOLAR) VIOLATION COUNTER

REGISTER 509 PMON RECEIVE LINE CODE (BIPOLAR) VIOLATION COUNTER LSB (RLCVCL) HEX ADDRESS: 0x0901

BIT	FUNCTION	TYPE	DEFAULT	DESCRIPTION-OPERATION
7	RLCVC[7]	RUR	0	These eight bits represent the LSB for the 16-bit Line Code Violation counter.
6	RLCVC[6]	RUR	0	
5	RLCVC[5]	RUR	0	
4	RLCVC[4]	RUR	0	
3	RLCVC[3]	RUR	0	
2	RLCVC[2]	RUR	0	
1	RLCVC[1]	RUR	0	
0	RLCVC[0]	RUR	0	

TABLE 93: PMON T1/E1 RECEIVE FRAMING ALIGNMENT BIT ERROR COUNTER

REGISTER 510 PMON RECEIVE FRAMING ALIGNMENT ERROR COUNTER MSB (RFAECU) HEX ADDRESS: 0x0902

BIT	FUNCTION	TYPE	DEFAULT	DESCRIPTION-OPERATION
7	RFAEC[15]	RUR	0	These eight bits represent the MSB for the 16-bit Receive Framing Alignment Error counter.
6	RFAEC[14]	RUR	0	
5	RFAEC[13]	RUR	0	
4	RFAEC[12]	RUR	0	
3	RFAEC[11]	RUR	0	
2	RFAEC[10]	RUR	0	
1	RFAEC[9]	RUR	0	
0	RFAEC[8]	RUR	0	

TABLE 94: PMON T1/E1 RECEIVE FRAMING ALIGNMENT BIT ERROR COUNTER

REGISTER 511 PMON RECEIVE FRAMING ALIGNMENT ERROR COUNTER LSB (RFAECL) HEX ADDRESS: 0x0903

BIT	FUNCTION	TYPE	DEFAULT	DESCRIPTION-OPERATION
7	RFAEC[7]	RUR	0	These eight bits represent the LSB for the 16-bit Receive Framing Alignment Error counter.
6	RFAEC[6]	RUR	0	
5	RFAEC[5]	RUR	0	
4	RFAEC[4]	RUR	0	
3	RFAEC[3]	RUR	0	
2	RFAEC[2]	RUR	0	
1	RFAEC[1]	RUR	0	
0	RFAEC[0]	RUR	0	

TABLE 95: PMON T1/E1 RECEIVE SEVERELY ERRORED FRAME COUNTER

REGISTER 512 PMON RECEIVE SEVERELY ERRORED FRAME COUNTER (RSEFC) HEX ADDRESS: 0x0904

BIT	FUNCTION	TYPE	DEFAULT	DESCRIPTION-OPERATION
7	RSEFC[7]	RUR	0	Severely Errored 8-bit frame accumulation Counter Note: A severely errored frame event is defined as the occurrence of two consecutive errored frame alignment signals that are not responsible for loss of frame alignment.
6	RSEFC[6]	RUR	0	
5	RSEFC[5]	RUR	0	
4	RSEFC[4]	RUR	0	
3	RSEFC[3]	RUR	0	
2	RSEFC[2]	RUR	0	
1	RSEFC[1]	RUR	0	
0	RSEFC[0]	RUR	0	

TABLE 96: PMON T1/E1 RECEIVE CRC-4 BLOCK ERROR COUNTER - MSB

REGISTER 513 PMON RECEIVE SYNCHRONIZATION BIT BLOCK ERROR COUNTER (RSBBECU) HEX ADDRESS: 0x0905

BIT	FUNCTION	TYPE	DEFAULT	DESCRIPTION-OPERATION
7	RSBBEC[15]	RUR	0	These eight bits represent the MSB for the 16-bit Receive Synchronization Bit Block Error counter.
6	RSBBEC[14]	RUR	0	
5	RSBBEC[13]	RUR	0	
4	RSBBEC[12]	RUR	0	
3	RSBBEC[11]	RUR	0	
2	RSBBEC[10]	RUR	0	
1	RSBBEC[9]	RUR	0	
0	RSBBEC[8]	RUR	0	

TABLE 97: PMON T1/E1 RECEIVE CRC-4 BLOCK ERROR COUNTER - LSB

REGISTER 514 PMON RECEIVE SYNCHRONIZATION BIT BLOCK ERROR COUNTER (RSBBECL) HEX ADDRESS: 0x0906

BIT	FUNCTION	TYPE	DEFAULT	DESCRIPTION-OPERATION
7	RSBBEC[7]	RUR	0	These eight bits represent the LSB for the 16-bit Receive Synchronization Bit Block Error counter.
6	RSBBEC[6]	RUR	0	
5	RSBBEC[5]	RUR	0	
4	RSBBEC[4]	RUR	0	
3	RSBBEC[3]	RUR	0	
2	RSBBEC[2]	RUR	0	
1	RSBBEC[1]	RUR	0	
0	RSBBEC[0]	RUR	0	

TABLE 98: PMON T1/E1 RECEIVE FAR-END BLOCK ERROR COUNTER - MSB

REGISTER 515 PMON RECEIVE FAR-END BLOCK ERROR COUNTER (RFEBCU) HEX ADDRESS: 0x0907

BIT	FUNCTION	TYPE	DEFAULT	DESCRIPTION-OPERATION
7	RFEBEC[15]	RUR	0	These eight bits represent the MSB for the 16-bit Receive Far-End Block Error counter.
6	RFEBEC[14]	RUR	0	
5	RFEBEC[13]	RUR	0	
4	RFEBEC[12]	RUR	0	
3	RFEBEC[11]	RUR	0	
2	RFEBEC[10]	RUR	0	
1	RFEBEC[9]	RUR	0	
0	RFEBEC[8]	RUR	0	

TABLE 99: PMON T1/E1 RECEIVE FAR END BLOCK ERROR COUNTER

REGISTER 516 PMON RECEIVE FAR END BLOCK ERROR COUNTER (RFEBECL) HEX ADDRESS: 0x0908

BIT	FUNCTION	TYPE	DEFAULT	DESCRIPTION-OPERATION
7	RFEBEC[7]	RUR	0	These eight bits represent the LSB for the 16-bit Receive Far-End Block Error counter. Note: Counter contains the 16-bit far-end block error event. Counter will increment once each time the received E-bit is set to zero. The counter is disabled during loss of sync at either the FAS or CRC-4 level and it will continue to count if loss of multiframe sync occurs at the CAS level.
6	RFEBEC[6]	RUR	0	
5	RFEBEC[5]	RUR	0	
4	RFEBEC[4]	RUR	0	
3	RFEBEC[3]	RUR	0	
2	RFEBEC[2]	RUR	0	
1	RFEBEC[1]	RUR	0	
0	RFEBEC[0]	RUR	0	

TABLE 100: PMON T1/E1 RECEIVE SLIP COUNTER

REGISTER 517 PMON RECEIVE SLIP COUNTER (RSC) HEX ADDRESS: 0x0909

BIT	FUNCTION	TYPE	DEFAULT	DESCRIPTION-OPERATION
7	RSC[7]	RUR	0	Note: counter contains the 8-bit receive buffer slip event. A slip event is defined as a replication or deletion of a T1/E1 frame by the receiving slip buffer. Note: A 16 bit counter which counts the occurrence of a bipolar violation on the receive data line. This counter is of sufficient length so that the probability of counter saturation over a one second interval at a 10 ⁻³ -Bit Error Rate (BER) is less than 0.001%.
6	RSC[6]	RUR	0	
5	RSC[5]	RUR	0	
4	RSC[4]	RUR	0	
3	RSC[3]	RUR	0	
2	RSC[2]	RUR	0	
1	RSC[1]	RUR	0	
0	RSC[0]	RUR	0	

TABLE 101: PMON T1/E1 RECEIVE LOSS OF FRAME COUNTER

REGISTER 518

PMON RECEIVE LOSS OF FRAME COUNTER (RLFC)

HEX ADDRESS: 0x090A

BIT	FUNCTION	TYPE	DEFAULT	DESCRIPTION-OPERATION
7	RLFC[7]	RUR	0	Note: LOFC (8-bit counter) is a count of the number of times a "Loss Of FAS Frame" has been declared. This counter provides the capability to measure an accumulation of short failure events.
6	RLFC[6]	RUR	0	
5	RLFC[5]	RUR	0	
4	RLFC[4]	RUR	0	
3	RLFC[3]	RUR	0	
2	RLFC[2]	RUR	0	
1	RLFC[1]	RUR	0	
0	RLFC[0]	RUR	0	

TABLE 102: PMON T1/E1 RECEIVE CHANGE OF FRAME ALIGNMENT COUNTER

REGISTER 519

PMON RECEIVE CHANGE OF FRAME ALIGNMENT COUNTER (RCFAC)

HEX ADDRESS: 0x090B

BIT	FUNCTION	TYPE	DEFAULT	DESCRIPTION-OPERATION
7	RCFAC[7]	RUR	0	Change of Frame Alignment Accumulation counter. Note: (8-bit counter) COFA is declared when the newly-locked framing is different from the one offered by off-line framer.
6	RCFAC[6]	RUR	0	
5	RCFAC[5]	RUR	0	
4	RCFAC[4]	RUR	0	
3	RCFAC[3]	RUR	0	
2	RCFAC[2]	RUR	0	
1	RCFAC[1]	RUR	0	
0	RCFAC[0]	RUR	0	

TABLE 103: PMON LAPD T1/E1 FRAME CHECK SEQUENCE ERROR COUNTER 1

REGISTER 520

PMON LAPD1 FRAME CHECK SEQUENCE ERROR COUNTER 1 (LFCSEC1)

HEX ADDRESS: 0x090C

BIT	FUNCTION	TYPE	DEFAULT	DESCRIPTION-OPERATION
7	FCSEC1[7]	RUR	0	Frame Check Sequence error Accumulation Counter 1. Note: 8-bit Counter accumulates the times of occurrence of receive frame check sequence error detected by LAPD1 controller.
6	FCSEC1[6]	RUR	0	
5	FCSEC1[5]	RUR	0	
4	FCSEC1[4]	RUR	0	
3	FCSEC1[3]	RUR	0	
2	FCSEC1[2]	RUR	0	
1	FCSEC1[1]	RUR	0	
0	FCSEC1[0]	RUR	0	

TABLE 104: T1/E1 PRBS BIT ERROR COUNTER MSB

REGISTER 521

T1/E1 PRBS BIT ERROR COUNTER MSB (PBEUC)

HEX ADDRESS: 0x090D

BIT	FUNCTION	TYPE	DEFAULT	DESCRIPTION-OPERATION
7	PRBSE[15]	RUR	0	Most significant bits of PRBS bit error Accumulation 16-bit counter
6	PRBSE[14]	RUR	0	
5	PRBSE[13]	RUR	0	
4	PRBSE[12]	RUR	0	
3	PRBSE[11]	RUR	0	
2	PRBSE[10]	RUR	0	
1	PRBSE[9]	RUR	0	
0	PRBSE[8]	RUR	0	

TABLE 105: T1/E1 PRBS BIT ERROR COUNTER LSB

REGISTER 522

T1/E1 PRBS BIT ERROR COUNTER LSB (PBECL)

HEX ADDRESS: 0x090E

BIT	FUNCTION	TYPE	DEFAULT	DESCRIPTION-OPERATION
7	PRBSE[7]	RUR	0	Least significant byte of PRBS bit error accumulation 16-bit counter.
6	PRBSE[6]	RUR	0	
5	PRBSE[5]	RUR	0	
4	PRBSE[4]	RUR	0	
3	PRBSE[3]	RUR	0	
2	PRBSE[2]	RUR	0	
1	PRBSE[1]	RUR	0	
0	PRBSE[0]	RUR	0	

TABLE 106: T1/E1 TRANSMIT SLIP COUNTER

REGISTER 523

T1/E1 TRANSMIT SLIP COUNTER (T1/E1TSC)

HEX ADDRESS: 0x090F

BIT	FUNCTION	TYPE	DEFAULT	DESCRIPTION-OPERATION
7	TxSLIP[7]	RUR	0	Transmit Slip accumulation counter.
6	TxSLIP[6]	RUR	0	
5	TxSLIP[5]	RUR	0	
4	TxSLIP[4]	RUR	0	
3	TxSLIP[3]	RUR	0	
2	TxSLIP[2]	RUR	0	
1	TxSLIP[1]	RUR	0	
0	TxSLIP[0]	RUR	0	

TABLE 107: T1/E1 EXCESSIVE ZERO VIOLATION COUNTER MSB

REGISTER 524

T1/E1 EXCESSIVE ZERO VIOLATION COUNTER MSB (EZVCU)

HEX ADDRESS: 0x0910

BIT	FUNCTION	TYPE	DEFAULT	DESCRIPTION-OPERATION
7	EZVC[15]	RUR	0	These eight bits represent the MSB for the 16-bit Excessive Zero Violation Counter.
6	EZVC[14]	RUR	0	
5	EZVC[13]	RUR	0	
4	EZVC[12]	RUR	0	
3	EZVC[11]	RUR	0	
2	EZVC[10]	RUR	0	
1	EZVC[9]	RUR	0	
0	EZVC[8]	RUR	0	

TABLE 108: T1/E1 EXCESSIVE ZERO VIOLATION COUNTER LSB

REGISTER 525

T1/E1 EXCESSIVE ZERO VIOLATION COUNTER MSB (EZVCL)

HEX ADDRESS: 0x0911

BIT	FUNCTION	TYPE	DEFAULT	DESCRIPTION-OPERATION
7	EZVC[7]	RUR	0	These eight bits represent the LSB for the 16-bit Excessive Zero Violation Counter.
6	EZVC[6]	RUR	0	
5	EZVC[5]	RUR	0	
4	EZVC[4]	RUR	0	
3	EZVC[3]	RUR	0	
2	EZVC[2]	RUR	0	
1	EZVC[1]	RUR	0	
0	EZVC[0]	RUR	0	

TABLE 109: T1/E1 FRAME CHECK SEQUENCE ERROR COUNTER 2

REGISTER 526

PMON LAPD2 FRAME CHECK SEQUENCE ERROR COUNTER 2 (LFCSEC2)

HEX ADDRESS: 0x091C

BIT	FUNCTION	TYPE	DEFAULT	DESCRIPTION-OPERATION
7	FCSEC2[7]	RUR	0	Frame Check Sequence error Accumulation Counter 2. Note: 8-bit Counter accumulates the times of occurrence of receive frame check sequence error detected by LAPD2 controller.
6	FCSEC2[6]	RUR	0	
5	FCSEC2[5]	RUR	0	
4	FCSEC2[4]	RUR	0	
3	FCSEC2[3]	RUR	0	
2	FCSEC2[2]	RUR	0	
1	FCSEC2[1]	RUR	0	
0	FCSEC2[0]	RUR	0	

TABLE 110: T1/E1 FRAME CHECK SEQUENCE ERROR COUNTER 3
REGISTER 527
PMON LAPD3 FRAME CHECK SEQUENCE ERROR COUNTER 3 (LFCSEC3)
HEX ADDRESS: 0x092C

BIT	FUNCTION	TYPE	DEFAULT	DESCRIPTION-OPERATION
7	FCSEC3[7]	RUR	0	Frame Check Sequence error Accumulation Counter 3. Note: 8-bit Counter accumulates the times of occurrence of receive frame check sequence error detected by LAPD3 controller.
6	FCSEC3[6]	RUR	0	
5	FCSEC3[5]	RUR	0	
4	FCSEC3[4]	RUR	0	
3	FCSEC3[3]	RUR	0	
2	FCSEC3[2]	RUR	0	
1	FCSEC3[1]	RUR	0	
0	FCSEC3[0]	RUR	0	

TABLE 111: BLOCK INTERRUPT STATUS REGISTER
REGISTER 528
BLOCK INTERRUPT STATUS REGISTER (BISR)
HEX ADDRESS: 0x0B00

BIT	FUNCTION	TYPE	DEFAULT	DESCRIPTION-OPERATION
7	Sa6	RO	0	Sa6 Interrupt Status
6	LBCODE	RO	0	Loopback Code Interrupt
5	RxCikLOS	RUR	0	RxClk Los Interrupt Status Indicates if Framer n has experienced a Loss of Recovered Clock interrupt since last read of this register. 0 = Loss of Recovered Clock interrupt has not occurred since last read of this register 1 = Loss of Recovered Clock interrupt has occurred since last read of this register.
4	ONESEC	RUR	0	One Second Interrupt Status Indicates if the XRT86L30 has experienced a One Second interrupt since the last read of this register. 0 = No outstanding One Second interrupts awaiting service 1 = Outstanding One Second interrupt awaits service
3	HDLC	RO	0	HDLC Block Interrupt Status Indicates if the HDLC block has an interrupt request awaiting service. 0 = No outstanding interrupt requests awaiting service 1 = HDLC Block has an interrupt request awaiting service. Interrupt Service routine should branch to and read Data Link Status Register (address xA,06). <i>NOTE: This bit-field will be reset to 0 after the microprocessor has performed a read to the Data Link Status Register.</i>

TABLE 111: BLOCK INTERRUPT STATUS REGISTER

REGISTER 528

BLOCK INTERRUPT STATUS REGISTER (BISR)

HEX ADDRESS: 0x0B00

BIT	FUNCTION	TYPE	DEFAULT	DESCRIPTION-OPERATION
2	SLIP	RO	0	Slip Buffer Block Interrupt Status Indicates if the Slip Buffer block has any outstanding interrupt requests awaiting service. 0 = No outstanding interrupts awaiting service 1 = Slip Buffer block has an interrupt awaiting service. Interrupt Service routine should branch to and read Slip Buffer Interrupt Status register (address 0xA,0x09). NOTE: This bit-field will be reset to 0 after the microprocessor has performed a read of the Slip Buffer Interrupt Status Register.
1	ALARM	RO	0	Alarm & Error Block Interrupt Status Indicates if the Alarm & Error Block has any outstanding interrupts that are awaiting service. 0 = No outstanding interrupts awaiting service 1 = Alarm & Error Block has an interrupt awaiting service. Interrupt SerStatus Register (address xA,02) NOTE: This bit-field will be reset to 0 after the microprocessor has performed a read of the Alarm & Error Interrupt Status register.
0	T1/E1 FRAME	RO	0	T1/E1 Framer Block Interrupt Status Indicates if an T1/E1 Frame Status interrupt request is awaiting service. 0 = No T1/E1 Frame Status interrupt is pending 1 = T1/E1 Framer Status interrupt is awaiting service.

TABLE 112: BLOCK INTERRUPT ENABLE REGISTER

REGISTER 529

BLOCK INTERRUPT ENABLE REGISTER (BIER)

HEX ADDRESS: 0x0B01

BIT	FUNCTION	TYPE	DEFAULT	DESCRIPTION-OPERATION
7	SA6_ENB	R/W	0	SA6 interrupt enable
6	LBCODE_ENB	R/W	0	Loopback code interrupt enable
5	RXCLKLOSS	R/W	0	RxLineClk Loss Interrupt Enable 0 = Disables interrupt 1 = Enables interrupt
4	ONESEC_ENB	R/W	0	One Second Interrupt Enable 0 = Disables interrupt 1 = Enables Interrupt
3	HDLC_ENB	R/W	0	HDLC Block Interrupt Enable 0 = Disables all HDLC Block interrupts 1 = Enables HDLC Block (for interrupt generation) at the block level
2	SLIP_ENB	R/W	0	Slip Buffer Block Interrupt Enable 0 = Disables all Slip Buffer Block Interrupts 1 = Enables Slip Buffer Block at the block level

TABLE 112: BLOCK INTERRUPT ENABLE REGISTER
REGISTER 529
BLOCK INTERRUPT ENABLE REGISTER (BIER)
HEX ADDRESS: 0x0B01

BIT	FUNCTION	TYPE	DEFAULT	DESCRIPTION-OPERATION
1	ALARM_ENB	R/W	0	Alarm & Error Block Interrupt Enable 0 = Disables all Alarm & Error Block interrupts 1 = Enables Alarm & Error block at the block level
0	T1/E1FRAME_ENB	R/W	0	T1/E1 Frame Block Enable 0 = Disables all Frame Block interrupts 1 = Enables the Frame Block at the block level

TABLE 113: ALARM & ERROR INTERRUPT STATUS REGISTER
REGISTER 530
ALARM & ERROR INTERRUPT STATUS REGISTER (AEISR)
HEX ADDRESS: 0x0B02

BIT	MOD E	FUNCTION	TYPE	DEFAULT	DESCRIPTION-OPERATION
7	E1/ T1	RxLOF State	RO	0	Receive Loss Of Frame State Reflects a current Loss of Framing condition as detected by the Receive T1/E1 Framer. 0 = Receive Framer not declaring Loss of Framing condition 1 = Receive Framer declaring Loss of Framing condition
6	E1/ T1	RxAIS State	RO	0	Receive Alarm Indication Status State This Read Only bit field indicates whether or not the receive T1/E1 Frame is currently detecting an AIS pattern in the incoming data stream. 0 = Receive Framer not detecting AIS pattern in incoming T1/E1 data stream 1 = Receive Framer detecting AIS pattern in incoming T1/E1 data stream
5	E1	RxMYEL Status	RUR	0	Receipt of CAS Multiframe Yellow Alarm Interrupt Status. The Receive E1 Framer will set this bit-field to 1 if it detects the CAS Multiframe Yellow Alarm in the incoming E1 data stream. 0 = Receipt of CAS Multiframe Yellow Alarm interrupt has not occurred since the last read of this register. 1 = Receipt of CAS Multiframe Yellow Alarm interrupt has occurred since the last read of this register.
5	T1	RxYEL_State	R	0	Yellow Alarm State Indicates a yellow alarm has been received. 0 = No yellow Alarm is Received 1 = Yellow alarm is received
4	E1/ T1	LOS Status	RUR	0	Loss of Signal Interrupt Status. The Receive E1 Framer will set this bit-field to 1 if it detects a consecutive string of 0's at the RxPOX_n and Rx0EG_n input pins for 32 bit period. 0 = LOS Interrupt has not occurred since the last read of this register 1 = LOS Interrupt has occurred since the last read of this register

TABLE 113: ALARM & ERROR INTERRUPT STATUS REGISTER

REGISTER 530

ALARM & ERROR INTERRUPT STATUS REGISTER (AEISR)

HEX ADDRESS: 0x0B02

BIT	MODE	FUNCTION	TYPE	DEFAULT	DESCRIPTION-OPERATION
3	E1/T1	LCV Int Status	RUR	0	Line Code Violation Interrupt Status. The Receive LIU Interrupt Block will set this bit-field to 1 if it detects a Line Code Violation in the incoming E1 data stream. 0 = Line Code Violation interrupt has not occurred since the last read of this register. 1 = Line Code Violation interrupt has occurred since the last read of this register.
2	E1/T1	RxLOF Status	RUR	0	Change in Receive Loss of Frame Condition Interrupt Status. The receive E1 Framer block will set this bit-field to 1 if the Receive E1 framer has transition into the In-Frame condition or Loss of Frame condition. 0 = Change in RxLOF Interrupt has not occurred since the last read of this register 1 = Change in RxLOF Interrupt has occurred since the last read of this register
1	E1/T1	RxAIS Status	RUR	0	Change in Receive AIS Condition Interrupt Status. The Receive E1 Framer will generate the Change in AIS Condition interrupt if it starts to detect the AIS pattern in the incoming data stream or if it no longer detects the AIS pattern in the incoming data stream. 0 = Change in AIS Condition Interrupt has not occurred since the last read of this register 1 = Change in AIS Condition Interrupt has occurred since the last read of this register
0	E1/T1	RxYEL Status	RUR	0	Receipt of FAS Frame Yellow Alarm Interrupt Status. The Receive E1 Framer will generate the FAS Frame Yellow Alarm interrupt if it detects the FAS Frame Yellow Alarm in the incoming E1 data stream. 0 = FAS Frame Yellow Alarm interrupt has not occurred 1 = FAS Frame Yellow Alarm interrupt has occurred since the last read of this register.

TABLE 114: ALARM & ERROR INTERRUPT ENABLE REGISTER - E1 MODE

REGISTER 531 E1 MODE

ALARM & ERROR INTERRUPT ENABLE REGISTER (AEIER)

HEX ADDRESS: 0x0B03

BIT	FUNCTION	TYPE	DEFAULT	DESCRIPTION-OPERATION
7-6	Reserved	-	-	Reserved
5	RxMYEL ENB	R/W	0	Multiframe Yellow alarm state change interrupt enable Enables the generation of an interrupt when the yellow alarm has been received. 0 = A multiframe yellow alarm (y bit equals to 1) will not generate an interrupt. 1 = A multiframe yellow alarm will generate an interrupt.

TABLE 114: ALARM & ERROR INTERRUPT ENABLE REGISTER - E1 MODE
REGISTER 531 E1 MODE ALARM & ERROR INTERRUPT ENABLE REGISTER (AEIER) HEX ADDRESS: 0x0B03

BIT	FUNCTION	TYPE	DEFAULT	DESCRIPTION-OPERATION
4	LOS ENB	R/W	0	Loss Of Signal interrupt enable Enables the interrupt generation when the loss of signal has been detected. 0 = Disables the interrupt generation of LOS detection. 1 = Enables the interrupt generation of LOS detection
3	BPV ENB	R/W	0	Bipolar violation interrupt enable Enables the interrupt generation of a bipolar violation. 0 = Disables the interrupt generation of a bipolar violation condition. 1 = Enables the interrupt generation of a bipolar violation condition.
2	RxLOF ENB	R/W	0	Red alarm state change interrupt enable Enables the interrupt generation when the change state of red alarm has been detected. 0 = Disables the interrupt generation of loss of frame detection. 1 = Enables the interrupt generation of loss of frame detection.
1	RxAIS ENB	R/W	0	AIS state change interrupt enable Enables the generation of an interrupt when the change state of AIS event has been detected. 0 = The state change of AIS does not generate an interrupt. 1 = The state change of AIS does generate an interrupt.
0	RxYEL ENB	R/W	0	Yellow alarm state change interrupt enable Enables the generation of an interrupt when the yellow alarm has been received. 0 = A yellow alarm (A bit equals to 1) will not generate an interrupt. 1 = A yellow alarm will generate an interrupt

TABLE 115: ALARM & ERROR INTERRUPT ENABLE REGISTER -T1 MODE
REGISTER 531 T1 MODE ALARM & ERROR INTERRUPT ENABLE REGISTER (AEIER) HEX ADDRESS: 0x0B03

BIT	FUNCTION	TYPE	DEFAULT	DESCRIPTION-OPERATION
7-5	Reserved	-	-	Reserved
4	LOS ENB	R/W	0	Loss Of Signal interrupt enable Enables the interrupt generation when the loss of signal has been detected. 0 = Disables the interrupt generation of LOS detection. 1 = Enables the interrupt generation of LOS detection.
3	BPV ENB	R/W	0	Bipolar violation interrupt enable Enables the interrupt generation of a bipolar violation. 0 = Disables the interrupt generation of a bipolar violation condition. 1 = Enables the interrupt generation of a bipolar violation condition.

TABLE 115: ALARM & ERROR INTERRUPT ENABLE REGISTER -T1 MODE

REGISTER 531 T1 MODE ALARM & ERROR INTERRUPT ENABLE REGISTER (AEIER) HEX ADDRESS: 0x0B03

BIT	FUNCTION	TYPE	DEFAULT	DESCRIPTION-OPERATION
2	RxRED ENB	R/W	0	Red Alarm State Change Interrupt Enable Enables the interrupt generation when the change state of red alarm has been detected. 0 = Disables the interrupt generation of framing mimic detection. 1 = Enables the interrupt generation of framing mimic detection.
1	RxAIS ENB	R/W	0	AIS state change interrupt enable Enable the generation of an interrupt when the change state of AIS event has been detected. 0 = The state change of AIS does not generate an interrupt. 1 = The state change of AIS does generate an interrupt
0	RxYEL ENB	R/W	0	Yellow alarm state change interrupt enable Enables the generation of an interrupt when the change state of yellow alarm has been detected. 0 = Any state change of yellow alarm will not generate an interrupt. 1 = Changing state of yellow alarm will generate an interrupt.

TABLE 116: FRAMER INTERRUPT STATUS REGISTER E1 MODE

REGISTER 532 E1 MODE FRAMER INTERRUPT STATUS REGISTER (FISR) HEX ADDRESS: 0x0B04

BIT	FUNCTION	TYPE	DEFAULT	DESCRIPTION-OPERATION
7	COMFA Status E1 Only	RUR	0	Change in CAS Multiframe Alignment Interrupt Status 0 = Change in CAS Multiframe Alignment Interrupt has not occurred since the last read of this register 1 = Change in CAS Multiframe Alignment Interrupt has occurred since the last read of this register
6	NBIT Status E1 Only	RUR	0	Change in National Bits Interrupt Status The Receive E1 Framer will generate this interrupt if it has detected a change in the National Bits in the incoming non-FAS E1 Frames. 0 = Change in National Bits Interrupt has not occurred since the last read of this register 1 = Change in National Bits Interrupt has occurred since the last read of this register.
5	SIG Status	RUR	0	Change in CAS Signaling Interrupt Status The Receive E1 Framer will generate this interrupt if it detects a change in the four-bit signaling values for any one of the 30 voice channels. 0 = Change in CAS Signaling Interrupt has not occurred since the last read of this register 1 = Change in CAS Signaling Interrupt has occurred since the last read of this register.
4	COFA Status	RUR	0	Change of FAS Frame Alignment Interrupt Status 0 = Change in FAS Frame Alignment interrupt has not occurred since the last read of this register 1 = Change in FAS Frame Alignment interrupt has occurred since the last read of this register

TABLE 116: FRAMER INTERRUPT STATUS REGISTER E1 MODE
REGISTER 532 E1 MODE
FRAMER INTERRUPT STATUS REGISTER (FISR)
HEX ADDRESS: 0x0B04

BIT	FUNCTION	TYPE	DEFAULT	DESCRIPTION-OPERATION
3	IF Status	RUR	0	Change of In Frame Condition Interrupt Status
2	FMD Status	RUR	0	
1	Sync Error Status	RUR	0	CRC-4 Error Interrupt Status. The Receive E1Framer will declare this interrupt if it detects an error in the CRC-4 bits within a given sub-multiframe. 0 = Sync Error has not occurred since the last read of this register 1 = Sync Error has occurred since the last read of this register
0	Framing Error Status	RUR	0	0 = Framing Bit Error interrupt has not occurred since the last read of this register 1 = Framing Bit Error interrupt has occurred since the last read of this register

TABLE 117: FRAMER INTERRUPT STATUS REGISTER T1 MODE
REGISTER 532 T1 MODE
FRAMER INTERRUPT STATUS REGISTER (FISR)
HEX ADDRESS: 0x0B04

BIT	FUNCTION	TYPE	DEFAULT	DESCRIPTION-OPERATION
5	SIG	RUR/ WC	0	Signaling updated This bit indicates the occurrence of state change of any signaling channel. 0 = No state change occurs of any signaling. 1 = Change of signaling state occurs.
4	COFA	RUR/ WC	0	Change of Frame Alignment This bit is used to indicate that the receive synchronization signal has changed alignment with respect to its last multiframe position. 0 = No COFA occurs. 1 = COFA occurs.
3	IF	RUR/ WC	0	In-frame state This bit indicates the occurrence of state change of in-frame indication. 0 = No state change occurs of in-frame indication. 1 = In-frame indication has changed state.
2	FMD	RUR/ WC	0	Frame Mimic state change This bit indicates the occurrence of state change of framing mimic detection. 0 = No state change occurs of framing mimic detection. 1 = Framing mimic detection has changed state.

TABLE 117: FRAMER INTERRUPT STATUS REGISTER T1 MODE

REGISTER 532 T1 MODE

FRAMER INTERRUPT STATUS REGISTER (FISR)

HEX ADDRESS: 0x0B04

BIT	FUNCTION	TYPE	DEFAULT	DESCRIPTION-OPERATION
1	SE	RUR/ WC	0	Synchronization bit error This bit indicates the occurrence of synchronization bit error event. 0 = No synchronization bit error occurs. 1 = Synchronization bit error occurs.
0	FE	RUR/ WC	0	Framing error This bit is used to indicate that one or more frame alignment bit error have occurred. This bit doesn't not necessarily indicate that synchronization has been lost. 0 = No framing bit error occurs. 1 = Framing bit error occurs.

TABLE 118: FRAMER INTERRUPT ENABLE REGISTER E1 MODE

REGISTER 533 E1 MODE

FRAMER INTERRUPT ENABLE REGISTER (FIER)

HEX ADDRESS: 0x0B05

BIT	FUNCTION	TYPE	DEFAULT	DESCRIPTION-OPERATION
7	COMFA ENB - E1 Only	R/W	0	Change in CAS Multiframe Alignment Interrupt Enable - E1 only 0 = Disables the Change in CAS Multiframe Alignment Interrupt 1 = Enables the Change in CAS Multiframe Alignment Interrupt
6	NBIT ENB - E1 Only	R/W	0	Change in National Bits Interrupt Enable - E1 only 0 = Disables the Change in National Bits Interrupt 1 = Enables the Change in National Bits Interrupt
5	SIG ENB	R/W	0	Change in CAS Signaling Bits Interrupt Enable 0 = Disables the Change in CAS Signaling Bits Interrupt Enable 1 = Enables the Change in CAS Signaling Bits Interrupt Enable
4	COFA ENB	R/W	0	Change in FAS Framing Alignment Interrupt Enable 0 = Disables the Change in FAS Framing Alignment Interrupt Enable 1 = Enables the Change in FAS Framing Alignment Interrupt Enable
3	IF ENB	R/w	0	IF Enable
2	FMD ENB	R/W	0	FMD Enable
1	SE_ENB	R/W	0	Sync (CRC-4) Error Interrupt Enable 0 = Sync Error Interrupt Disabled 1 = Sync Error Interrupt Enabled
0	FE_ENB	R/W0	0	Framing Bit Error Interrupt Enable 0 = Disables the Framing Bit Error Interrupt 1 = Enables the Framing Bit Error Interrupt

TABLE 119: FRAMER INTERRUPT ENABLE REGISTER T1 MODE

REGISTER 533 T1 MODE

FRAMER INTERRUPT ENABLE REGISTER (FIER)

HEX ADDRESS: 0x0B05

BIT	FUNCTION	TYPE	DEFAULT	DESCRIPTION-OPERATION
5	SIG_ENB	R/W	0	This bits enables the generation of an interrupt when any signaling channel has changed state. 0 = Change of signaling data does not generate an interrupt. 1 = Change of signaling data does generate an interrupt.
4	COFA_ENB	R/W	0	Setting this bit will enable the interrupt generation when the frame search logic determines that frame alignment has been reached and that the new alignment differs from the previous alignment. 0 = Disables the interrupt generation of COFA detection. 1 = Enables the interrupt generation of COFA detection.
3	IF_ENB	R/W	0	IF Enable Setting this bit will enable the interrupt generation of an in-frame recognition. 0 = Disables the interrupt generation of an in-frame detection. 1 = Enables the interrupt generation of an in-frame detection.
2	FMD_ENB	R/W	0	FMD Enable Setting this bit will enable the interrupt generation when the frame search logic detects the presence of framing bit mimics. 0 = Disables the interrupt generation of framing mimic detection. 1 = Enables the interrupt generation of framing mimic detection.
1	SE_ENB	R/W	0	Sync (CRC-4) Error Interrupt Enable Setting this bit will enable the generation of an interrupt when a synchronization bit error event has been detected. A synchronization bit error event is defined as CRC-4 error. 0 = The detection of synchronization bit errors does not generate an interrupt. 1 = The detection of synchronization bit errors does generate an interrupt
0	FE_ENB	R/W0	0	Framing Bit Error Interrupt Enable This bits enables the generation of an interrupt when a framing bit error has been detected. 0 = Any error in the framing bits does not generate an interrupt. 1 = A error in the framing bits does generate an interrupt.

TABLE 120: DATA LINK STATUS REGISTER 1

REGISTER 534

DATA LINK STATUS REGISTER 1 (DLSR1)

HEX ADDRESS: 0x0B06

BIT	FUNCTION	TYPE	DEFAULT	DESCRIPTION-OPERATION
7	MSG TYPE	RUR	0	<p>HDLC1 Message Type Identifier</p> <p>Indicates type of data link message received by Rx HDLC1 Controller</p> <p>0 = Bit Oriented Signaling type data link message received 1 = Message Oriented Signaling type data link message received</p>
6	TxsOT	RUR	0	<p>Transmit HDLC1 Start of Transmission Interrupt Status</p> <p>Indicates if the Transmit HDLC1 Start of Transmission Interrupt has occurred since the last read of this register. Transmit HDLC1 Controller will declare this interrupt when it has started to transmit a data link message.</p> <p>0 = Transmit HDLC1 Start of Transmission interrupt has not occurred since the last read of this register 1 = Transmit HDLC1 Start of Transmission interrupt has occurred since the last read of this register.</p>
5	RxsOT	RUR	0	<p>Receive HDLC1 Start of Reception Interrupt Status</p> <p>Indicates if the Receive HDLC1 Start of Reception interrupt has occurred since the last read of this register. Receive HDLC1 Controller will declare this interrupt when it has started to receive a data link message.</p> <p>0 = Receive HDLC1 Start of Reception interrupt has not occurred since the last read of this register 1 = Receive HDLC1 Start of Reception interrupt has occurred since the last read of this register</p>
4	TxEOT	RUR	0	<p>Transmit HDLC1 End of Transmission Interrupt Status</p> <p>Indicates if the Transmit HDLC1 End of Transmission Interrupt has occurred since the last read of this register. Transmit HDLC1 Controller will declare this interrupt when it has completed its transmission of a data link message.</p> <p>0 = Transmit HDLC1 End of Transmission interrupt has not occurred since the last read of this register 1 = Transmit HDLC1 End of Transmission interrupt has occurred since the last read of this register</p>
3	RxEOT	RUR	0	<p>Receive HDLC1 Controller End of Reception Interrupt Status</p> <p>Indicates if Receive HDLC1 End of Reception Interrupt has occurred since the last read of this register. Receive HDLC1 Controller will declare this interrupt once it has completely received a full data link message.</p> <p>0 = Receive HDLC1 End of Reception interrupt has not occurred since the last read of this register 1 = Receive HDLC1 End of Reception Interrupt has occurred since the last read of this register</p>

TABLE 120: DATA LINK STATUS REGISTER 1
REGISTER 534
DATA LINK STATUS REGISTER 1 (DLSR1)
HEX ADDRESS: 0x0B06

BIT	FUNCTION	TYPE	DEFAULT	DESCRIPTION-OPERATION
2	FCS Error	RUR	0	FCS Error Interrupt Status Indicates if the FCS Error Interrupt has occurred since the last read of this register. Receive HDLC1 Controller will declare this interrupt if it detects an error in the most recently received data message. 0 = FCS Error interrupt has not occurred since last read of this register 1 = FCS Error interrupt has occurred since last read of this register
1	Rx ABORT	RUR	0	Receipt of Abort Sequence Interrupt Status Indicates if the Receipt of Abort interrupt has occurred since last read of this register. Receive HDLC1 Controller will declare this interrupt if it detects a string of seven (7) consecutive 1's in the incoming data link channel. 0 = Receipt of Abort Sequence interrupt has not occurred since last read of this register 1 = Receipt of Abort Sequence interrupt has occurred since last read of this register
0	RxIDLE	RUR	0	Receipt of Idle Sequence Interrupt Status Indicates if the Receipt of Idle Sequence interrupt has occurred since the last read of this register. The Receive HDLC1 Controller will declare this interrupt if it detects the flag sequence octet (0x7E) in the incoming data link channel. 0 = Receipt of Idle Sequence interrupt has not occurred since last read of this register 1 = Receipt of Idle Sequence interrupt has occurred since last read of this register.

TABLE 121: DATA LINK INTERRUPT ENABLE REGISTER 1
REGISTER 535
DATA LINK INTERRUPT ENABLE REGISTER 1 (DLIER1)
HEX ADDRESS: 0x0B07

BIT	FUNCTION	TYPE	DEFAULT	DESCRIPTION-OPERATION
7	Reserved	-	-	Reserved
6	TxSOT ENB	R/W	0	Transmit HDLC1 Start of Transmission Interrupt Enable 0 = Disables the Transmit HDLC1 Start of Transmission interrupt 1 = Enables the Transmit HDLC1 Start of Transmission interrupt
5	RxSOT ENB	R/W	0	Receive HDLC1 Start of Reception Interrupt Enable 0 = Disables the Receive HDLC1 Start of Reception interrupt 1 = Enables the Receive HDLC1 Start of Reception interrupt
4	TxEOT ENB	R/W	0	Transmit HDLC1 End of Transmission Interrupt Enable 0 = Disables the Transmit HDLC1 End of Transmission interrupt 1 = Enables the Transmit HDLC1 End of Transmission interrupt
3	RxEOT ENB	R/W	0	Receive HDLC1 End of Reception Interrupt Enable 0 = Disables the Receive HDLC1 End of Reception interrupt 1 = Enables the Receive HDLC1 End of Reception interrupt

TABLE 121: DATA LINK INTERRUPT ENABLE REGISTER 1

REGISTER 535

DATA LINK INTERRUPT ENABLE REGISTER 1 (DLIER1)

HEX ADDRESS: 0x0B07

BIT	FUNCTION	TYPE	DEFAULT	DESCRIPTION-OPERATION
2	FCS ERR ENB	R/W	0	FCS Error Interrupt Enable 0 = Disables FCS Error interrupt 1 = Enables FCS Error interrupt
1	RxABORT ENB	R/W	0	Receipt of Abort Sequence Interrupt Enable 0 = Disables Receipt of Abort Sequence interrupt 1 = Enables Receive of Abort Sequence interrupt
0	RxIDLE ENB	R/W	0	Receipt of Idle Sequence Interrupt Enable 0 = Disables Receipt of Idle Sequence interrupt 1 = Enables Receipt of Idle Sequence interrupt

TABLE 122: SLIP BUFFER INTERRUPT STATUS REGISTER (SBISR)

REGISTER 536

SLIP BUFFER INTERRUPT STATUS REGISTER (SBISR)

HEX ADDRESS: 0x0B08

BIT	FUNCTION	TYPE	DEFAULT	DESCRIPTION-OPERATION
7	TxSB_FULL	RUR/ WC	0	Slip buffer fills & a frame is deleted This bit is set when the elastic store fills and a frame is deleted.
6	TxSB_EMPT	RUR/ WC	0	Slip buffer empties and a frame is repeated This bit is set when the elastic store empties and a frame is repeated.
5	TxSB_SLIP	RUR/ WC	0	Receive slips This bit is set when the slip buffer slips.
4	96LOCK	R	0	SLC@96 is in sync This bit indicates that SLC96 is in sync.
3	MLOCK	R	0	Multiframe is in Sync This bit indicates that multiframe is in sync.
2	SB_FULL	RUR/ WC	0	Slip buffer fills & a frame is deleted This bit is set when the elastic store fills and a frame is deleted.
1	SB_EMPT	RUR/ WC	0	Slip buffer empties and a frame is repeated This bit is set when the elastic store empties and a frame is repeated.
0	SB_SLIP	RUR/ WC	0	Receive slips This bit is set when the slip buffer slips.

TABLE 123: SLIP BUFFER INTERRUPT ENABLE REGISTER (SBIER)
REGISTER 537
SLIP BUFFER INTERRUPT ENABLE REGISTER (SBIER)
HEX ADDRESS: 0x0B09

BIT	FUNCTION	TYPE	DEFAULT	DESCRIPTION-OPERATION
7	TxFULL_ENB	R/W	0	Tx Interrupt Enable bit for slip buffer full Setting this bit enables interrupt when the elastic store fills and a frame is deleted.
6	TxEMPT_ENB	R/W	0	Tx Interrupt Enable bit for slip buffer empty Setting this bit enables interrupt when the elastic store empties and a frame is repeated.
5	TxSLIP_ENB	R/W	0	Tx Interrupt Enable bit for Slip buffer slip Setting this bit enables interrupt when the slip buffer slips.
4-3	Reserved	-	-	Reserved
2	FULL_ENB	R/W	0	Interrupt Enable bit for slip buffer full Setting this bit enables interrupt when the elastic store fills and a frame is deleted.
1	EMPT_ENB	R/W	0	Interrupt Enable bit for slip buffer empty Setting this bit enables interrupt when the elastic store empties and a frame is repeated.
0	SLIP_ENB	R/W	0	Interrupt Enable bit for Slip buffer slip Setting this bit enables interrupt when the slip buffer slips.

TABLE 124: RECEIVE LOOPBACK CODE INTERRUPT AND STATUS REGISTER (RLCISR)
REGISTER 538
RECEIVE LOOPBACK CODE INTERRUPT AND STATUS REGISTER (RLCISR)
HEX ADDRESS: 0x0B0A

BIT	FUNCTION	TYPE	DEFAULT	DESCRIPTION-OPERATION
7	AUXPSTAT	R	0	AUXP state This bit indicates the status of receive AUXP pattern.
6	AUXPINT	RUR/WC	0	AUXP state change interrupt 1 = Indicates the receive AUXP status has changed.
5	NONCRCSTAT	R	0	CRC-4-to-non-CRC-4 interworking status This bit indicates the status of CRC-4 interworking status in MODENB mode. 1 = CRC-4-to-non-CRC-4 interworking is established.
4	NONCRCINT	RUR/WC	0	CRC-4-to-non-CRC-4 interworking interrupt 1 = Indicates the interworking status has changed.
3	RXASTAT	R	0	Receive activation status This bit indicates the status of receive activation process. 1 = Indicates the loopback code activation is received.
2	RXDSTAT	R	0	Receive deactivation status This bit indicates the status of receive deactivation process. 1 = Indicates the loopback code deactivation is received.

TABLE 124: RECEIVE LOOPBACK CODE INTERRUPT AND STATUS REGISTER (RLCISR)

REGISTER 538 RECEIVE LOOPBACK CODE INTERRUPT AND STATUS REGISTER (RLCISR) HEX ADDRESS: 0x0B0A

BIT	FUNCTION	TYPE	DEFAULT	DESCRIPTION-OPERATION
1	RXAINT	RUR/WC	0	Receive activation interrupt 1 = Indicates the loopback code activation status has changed.
0	RXDINT	RUR/WC	0	Receive deactivation interrupt 1 = Indicates the loopback code deactivation status has changed.

TABLE 125: RECEIVE LOOPBACK CODE INTERRUPT ENABLE REGISTER (RLCIER)

REGISTER 539 RECEIVE LOOPBACK CODE INTERRUPT ENABLE REGISTER (RLCIER) HEX ADDRESS: 0x0B0B

BIT	FUNCTION	TYPE	DEFAULT	DESCRIPTION-OPERATION
6	AUXPINTENB	R/W	0	AUXP interrupt enable 1 = Enables the receive AUXP detect interrupt.
5	Reserved	-	-	Reserved
4	NONCRCENB	R/W	0	CRC-4 interworking interrupt enable 1 = Enables the CRC-4-non-CRC-4 interworking interrupt.
3-2	Reserved	-	-	Reserved
1	RXAENB	R/W	0	Receive activation interrupt enable 1 = Enables the loopback code activation interrupt.
0	RXDENB	R/W	0	Receive deactivation interrupt enable 1 = Enables the loopback code deactivation interrupt.

TABLE 126: RECEIVE SA INTERRUPT REGISTER (RSAIR)

REGISTER 540 RECEIVE SA INTERRUPT REGISTER (RSAIR) HEX ADDRESS: 0x0B0C

BIT	FUNCTION	TYPE	DEFAULT	DESCRIPTION-OPERATION
7	SA6_1111	R/W	0	Debounced Sa6 = 1111 received 1 = Indicates a debounced Sa6 = 1111 has been received.
6	SA6_1110	R/W	0	Debounced Sa6 = 1110 received 1 = Indicates a debounced Sa6 = 1110 has been received.
5	SA6_1100	R/W	0	Debounced Sa6 = 1100 received 1 = Indicates a debounced Sa6 = 1100 has been received.
4	SA6_1010	R/W	0	Debounced Sa6 = 1010 received 1 = Indicates a debounced Sa6 = 1010 has been received.
3	SA6_1000	R/W	0	Debounced Sa6 = 1000 received 1 = Indicates a debounced Sa6 = 1000 has been received.
2	SA6_001x	R/W	0	Debounced Sa6 = 001x received 1 = Indicates a debounced Sa6 = 001x has been received.

TABLE 126: RECEIVE SA INTERRUPT REGISTER (RSAIR)
REGISTER 540
RECEIVE SA INTERRUPT REGISTER (RSAIR)
HEX ADDRESS: 0x0B0C

BIT	FUNCTION	TYPE	DEFAULT	DESCRIPTION-OPERATION
1	SA6_other	R/W	0	Debounced Sa6 = other received 1 = Indicates a debounced Sa6 equals to other combination received.
0	SA6_0000	R/W	0	Debounced Sa6 = 0000 received 1 = Indicates a debounced Sa6 = 0000 has been received.

TABLE 127: RECEIVE SA INTERRUPT ENABLE REGISTER (RSAIER)
REGISTER 541
RECEIVE SA INTERRUPT ENABLE REGISTER (RSAIER)
HEX ADDRESS: 0x0B0D

BIT	FUNCTION	TYPE	DEFAULT	DESCRIPTION-OPERATION
7	SA6_1111_ENB	R/W	0	Debounced Sa6 = 1111 received enable 1 = Indicates a debounced Sa6 = 1111 has been received.
6	SA6_1110_ENB	R/W	0	Debounced Sa6 = 1110 received enable 1 = Enables the generation of an interrupt when a debounced Sa6 = 1111 has been received.
5	SA6_1100_ENB	R/W	0	Debounced Sa6 = 1100 received enable 1 = Enables the generation of an interrupt when a debounced Sa6 = 1111 has been received.
4	SA6_1010_ENB	R/W	0	Debounced Sa6 = 1010 received enable 1 = Enables the generation of an interrupt when a debounced Sa6 = 1111 has been received.
3	SA6_1000_ENB	R/W	0	Debounced Sa6 = 1000 received enable 1 = Enables the generation of an interrupt when a debounced Sa6 = 1111 has been received.
2	SA6_001x_ENB	R/W	0	Debounced Sa6 = 001x received enable 1 = Enables the generation of an interrupt when a debounced Sa6 = 1111 has been received.
1	SA6_other_ENB	R/W	0	Debounced Sa6 = other received enable 1 = Enables the generation of an interrupt when a debounced Sa6 equals to other combinations received.
0	SA6_0000_ENB	R/W	0	Debounced Sa6 = 0000 received enable 1 = Enables the generation of an interrupt when a debounced Sa6 = 0000 has been received.

TABLE 128: EXCESSIVE ZERO STATUS REGISTER
REGISTER 542
EXCESSIVE ZERO STATUS REGISTER (EXZSR)
HEX ADDRESS: 0x0B0E

BIT	FUNCTION	TYPE	DEFAULT	DESCRIPTION-OPERATION
0	EXZ_STATUS	RUR	0	Excessive Zero State Change 0 = No change in status 1 = Change in status has occurred

TABLE 129: EXCESSIVE ZERO ENABLE REGISTER

REGISTER 543

EXCESSIVE ZERO ENABLE REGISTER (EXZER)

HEX ADDRESS: 0x0B0F

BIT	FUNCTION	TYPE	DEFAULT	DESCRIPTION-OPERATION
0	EXZ_ENB	R/W	0	Excessive Zero Interrupt Enable 0 = Disabled 1 = Enable excessive zero interrupt generation

TABLE 130: SS7 STATUS REGISTER FOR LAPD1

REGISTER 544

SS7 STATUS REGISTER FOR LAPD1 (SS7SR1)

HEX ADDRESS: 0x0B10

BIT	FUNCTION	TYPE	DEFAULT	DESCRIPTION-OPERATION
0	SS7_1_STATUS	RUR	0	SS7 Interrupt Status for LAPD1 0 = No change in status 1 = Change in status has occurred

TABLE 131: SS7 ENABLE REGISTER FOR LAPD1

REGISTER 545

SS7 ENABLE REGISTER FOR LAPD1 (SS7ER1)

HEX ADDRESS: 0x0B11

BIT	FUNCTION	TYPE	DEFAULT	DESCRIPTION-OPERATION
0	SS7_1_ENB	R/W	0	SS7 Interrupt Enable for LAPD1 0 = Disabled 1 = Enable SS7 interrupt generation if more than 276 bytes are received within the LAPD1 message

TABLE 132: DATA LINK STATUS REGISTER 2

REGISTER 546

DATA LINK STATUS REGISTER 2 (DLSR2)

HEX ADDRESS: 0x0B16

BIT	FUNCTION	TYPE	DEFAULT	DESCRIPTION-OPERATION
7	MSG TYPE	RUR	0	HDLC2 Message Type Identifier Indicates type of data link message received by Rx HDLC2 Controller 0 = Bit Oriented Signaling type data link message received 1 = Message Oriented Signaling type data link message received
6	TxSOT	RUR	0	Transmit HDLC2 Start of Transmission Interrupt Status Indicates if the Transmit HDLC2 Start of Transmission Interrupt has occurred since the last read of this register. Transmit HDLC2 Controller will declare this interrupt when it has started to transmit a data link message. 0 = Transmit HDLC2 Start of Transmission interrupt has not occurred since the last read of this register 1 = Transmit HDLC2 Start of Transmission interrupt has occurred since the last read of this register.

TABLE 132: DATA LINK STATUS REGISTER 2

REGISTER 546

DATA LINK STATUS REGISTER 2 (DLR2)

HEX ADDRESS: 0x0B16

BIT	FUNCTION	TYPE	DEFAULT	DESCRIPTION-OPERATION
5	RxSOT	RUR	0	<p>Receive HDLC2 Start of Reception Interrupt Status</p> <p>Indicates if the Receive HDLC2 Start of Reception interrupt has occurred since the last read of this register. Receive HDLC2 Controller will declare this interrupt when it has started to receive a data link message.</p> <p>0 = Receive HDLC2 Start of Reception interrupt has not occurred since the last read of this register</p> <p>1 = Receive HDLC2 Start of Reception interrupt has occurred since the last read of this register</p>
4	TxEOT	RUR	0	<p>Transmit HDLC2 End of Transmission Interrupt Status</p> <p>Indicates if the Transmit HDLC2 End of Transmission Interrupt has occurred since the last read of this register. Transmit HDLC2 Controller will declare this interrupt when it has completed its transmission of a data link message.</p> <p>0 = Transmit HDLC2 End of Transmission interrupt has not occurred since the last read of this register</p> <p>1 = Transmit HDLC2 End of Transmission interrupt has occurred since the last read of this register</p>
3	RxEOT	RUR	0	<p>Receive HDLC2 Controller End of Reception Interrupt Status</p> <p>Indicates if Receive HDLC2 End of Reception Interrupt has occurred since the last read of this register. Receive HDLC2 Controller will declare this interrupt once it has completely received a full data link message.</p> <p>0 = Receive HDLC2 End of Reception interrupt has not occurred since the last read of this register</p> <p>1 = Receive HDLC2 End of Reception Interrupt has occurred since the last read of this register</p>
2	FCS Error	RUR	0	<p>FCS Error Interrupt Status</p> <p>Indicates if the FCS Error Interrupt has occurred since the last read of this register. Receive HDLC2 Controller will declare this interrupt if it detects an error in the most recently received data message.</p> <p>0 = FCS Error interrupt has not occurred since last read of this register</p> <p>1 = FCS Error interrupt has occurred since last read of this register</p>

TABLE 132: DATA LINK STATUS REGISTER 2

REGISTER 546

DATA LINK STATUS REGISTER 2 (DLSR2)

HEX ADDRESS: 0x0B16

BIT	FUNCTION	TYPE	DEFAULT	DESCRIPTION-OPERATION
1	Rx ABORT	RUR	0	Receipt of Abort Sequence Interrupt Status Indicates if the Receipt of Abort interrupt has occurred since last read of this register. Receive HDLC2 Controller will declare this interrupt if it detects a string of seven (7) consecutive 1's in the incoming data link channel. 0 = Receipt of Abort Sequence interrupt has not occurred since last read of this register 1 = Receipt of Abort Sequence interrupt has occurred since last read of this register
0	RxIDLE	RUR	0	Receipt of Idle Sequence Interrupt Status Indicates if the Receipt of Idle Sequence interrupt has occurred since the last read of this register. The Receive HDLC2 Controller will declare this interrupt if it detects the flag sequence octet (0x7E) in the incoming data link channel. 0 = Receipt of Idle Sequence interrupt has not occurred since last read of this register 1 = Receipt of Idle Sequence interrupt has occurred since last read of this register.

TABLE 133: DATA LINK INTERRUPT ENABLE REGISTER 2

REGISTER 547

DATA LINK INTERRUPT ENABLE REGISTER 2 (DLIER2)

HEX ADDRESS: 0x0B17

BIT	FUNCTION	TYPE	DEFAULT	DESCRIPTION-OPERATION
7	Reserved	-	-	Reserved
6	TxSOT ENB	R/W	0	Transmit HDLC2 Start of Transmission Interrupt Enable 0 = Disables the Transmit HDLC2 Start of Transmission interrupt 1 = Enables the Transmit HDLC2 Start of Transmission interrupt
5	RxSOT ENB	R/W	0	Receive HDLC2 Start of Reception Interrupt Enable 0 = Disables the Receive HDLC2 Start of Reception interrupt 1 = Enables the Receive HDLC2 Start of Reception interrupt
4	TxEOT ENB	R/W	0	Transmit HDLC2 End of Transmission Interrupt Enable 0 = Disables the Transmit HDLC2 End of Transmission interrupt 1 = Enables the Transmit HDLC2 End of Transmission interrupt
3	RxEOT ENB	R/W	0	Receive HDLC2 End of Reception Interrupt Enable 0 = Disables the Receive HDLC2 End of Reception interrupt 1 = Enables the Receive HDLC2 End of Reception interrupt
2	FCS ERR ENB	R/W	0	FCS Error Interrupt Enable 0 = Disables FCS Error interrupt 1 = Enables FCS Error interrupt

TABLE 133: DATA LINK INTERRUPT ENABLE REGISTER 2

REGISTER 547 DATA LINK INTERRUPT ENABLE REGISTER 2 (DLIER2) HEX ADDRESS: 0x0B17

BIT	FUNCTION	TYPE	DEFAULT	DESCRIPTION-OPERATION
1	RxABORT ENB	R/W	0	Receipt of Abort Sequence Interrupt Enable 0 = Disables Receipt of Abort Sequence interrupt 1 = Enables Receive of Abort Sequence interrupt
0	RxIDLE ENB	R/W	0	Receipt of Idle Sequence Interrupt Enable 0 = Disables Receipt of Idle Sequence interrupt 1 = Enables Receipt of Idle Sequence interrupt

TABLE 134: SS7 STATUS REGISTER FOR LAPD2

REGISTER 548 SS7 STATUS REGISTER FOR LAPD2 (SS7SR2) HEX ADDRESS: 0x0B18

BIT	FUNCTION	TYPE	DEFAULT	DESCRIPTION-OPERATION
0	SS7_2_STATUS	RUR	0	SS7 Interrupt Status for LAPD2 0 = No change in status 1 = Change in status has occurred

TABLE 135: SS7 ENABLE REGISTER FOR LAPD2

REGISTER 549 SS7 ENABLE REGISTER FOR LAPD2 (SS7ER2) HEX ADDRESS: 0x0B19

BIT	FUNCTION	TYPE	DEFAULT	DESCRIPTION-OPERATION
0	SS7_2_ENB	R/W	0	SS7 Interrupt Enable for LAPD2 0 = Disabled 1 = Enable SS7 interrupt generation if more than 276 bytes are received within the LAPD2 message

TABLE 136: DATA LINK STATUS REGISTER 3

REGISTER 550 DATA LINK STATUS REGISTER 3 (DLSR3) HEX ADDRESS: 0x0B26

BIT	FUNCTION	TYPE	DEFAULT	DESCRIPTION-OPERATION
7	MSG TYPE	RUR	0	HDLC3 Message Type Identifier Indicates type of data link message received by Rx HDLC3 Controller 0 = Bit Oriented Signaling type data link message received 1 = Message Oriented Signaling type data link message received
6	TxSOT	RUR	0	Transmit HDLC3 Start of Transmission Interrupt Status Indicates if the Transmit HDLC3 Start of Transmission Interrupt has occurred since the last read of this register. Transmit HDLC3 Controller will declare this interrupt when it has started to transmit a data link message. 0 = Transmit HDLC3 Start of Transmission interrupt has not occurred since the last read of this register 1 = Transmit HDLC3 Start of Transmission interrupt has occurred since the last read of this register.

TABLE 136: DATA LINK STATUS REGISTER 3

REGISTER 550

DATA LINK STATUS REGISTER 3 (DLSR3)

HEX ADDRESS: 0x0B26

BIT	FUNCTION	TYPE	DEFAULT	DESCRIPTION-OPERATION
5	RxSOT	RUR	0	<p>Receive HDLC3 Start of Reception Interrupt Status</p> <p>Indicates if the Receive HDLC3 Start of Reception interrupt has occurred since the last read of this register. Receive HDLC3 Controller will declare this interrupt when it has started to receive a data link message.</p> <p>0 = Receive HDLC3 Start of Reception interrupt has not occurred since the last read of this register</p> <p>1 = Receive HDLC3 Start of Reception interrupt has occurred since the last read of this register</p>
4	TxEOT	RUR	0	<p>Transmit HDLC3 End of Transmission Interrupt Status</p> <p>Indicates if the Transmit HDLC3 End of Transmission Interrupt has occurred since the last read of this register. Transmit HDLC3 Controller will declare this interrupt when it has completed its transmission of a data link message.</p> <p>0 = Transmit HDLC3 End of Transmission interrupt has not occurred since the last read of this register</p> <p>1 = Transmit HDLC3 End of Transmission interrupt has occurred since the last read of this register</p>
3	RxEOT	RUR	0	<p>Receive HDLC3 Controller End of Reception Interrupt Status</p> <p>Indicates if Receive HDLC3 End of Reception Interrupt has occurred since the last read of this register. Receive HDLC3 Controller will declare this interrupt once it has completely received a full data link message.</p> <p>0 = Receive HDLC3 End of Reception interrupt has not occurred since the last read of this register</p> <p>1 = Receive HDLC3 End of Reception Interrupt has occurred since the last read of this register</p>
2	FCS Error	RUR	0	<p>FCS Error Interrupt Status</p> <p>Indicates if the FCS Error Interrupt has occurred since the last read of this register. Receive HDLC3 Controller will declare this interrupt if it detects an error in the most recently received data message.</p> <p>0 = FCS Error interrupt has not occurred since last read of this register</p> <p>1 = FCS Error interrupt has occurred since last read of this register</p>

TABLE 136: DATA LINK STATUS REGISTER 3

REGISTER 550

DATA LINK STATUS REGISTER 3 (DLSR3)

HEX ADDRESS: 0x0B26

BIT	FUNCTION	TYPE	DEFAULT	DESCRIPTION-OPERATION
1	Rx ABORT	RUR	0	<p>Receipt of Abort Sequence Interrupt Status</p> <p>Indicates if the Receipt of Abort interrupt has occurred since last read of this register. Receive HDLC3 Controller will declare this interrupt if it detects a string of seven (7) consecutive 1's in the incoming data link channel.</p> <p>0 = Receipt of Abort Sequence interrupt has not occurred since last read of this register</p> <p>1 = Receipt of Abort Sequence interrupt has occurred since last read of this register</p>
0	RxIDLE	RUR	0	<p>Receipt of Idle Sequence Interrupt Status</p> <p>Indicates if the Receipt of Idle Sequence interrupt has occurred since the last read of this register. The Receive HDLC2 Controller will declare this interrupt if it detects the flag sequence octet (0x7E) in the incoming data link channel.</p> <p>0 = Receipt of Idle Sequence interrupt has not occurred since last read of this register</p> <p>1 = Receipt of Idle Sequence interrupt has occurred since last read of this register.</p>

TABLE 137: DATA LINK INTERRUPT ENABLE REGISTER 3

REGISTER 551

DATA LINK INTERRUPT ENABLE REGISTER 3 (DLIER3)

HEX ADDRESS: 0x0B27

BIT	FUNCTION	TYPE	DEFAULT	DESCRIPTION-OPERATION
7	Reserved	-	-	Reserved
6	TxSOT ENB	R/W	0	<p>Transmit HDLC3 Start of Transmission Interrupt Enable</p> <p>0 = Disables the Transmit HDLC3 Start of Transmission interrupt</p> <p>1 = Enables the Transmit HDLC3 Start of Transmission interrupt</p>
5	RxSOT ENB	R/W	0	<p>Receive HDLC3 Start of Reception Interrupt Enable</p> <p>0 = Disables the Receive HDLC3 Start of Reception interrupt</p> <p>1 = Enables the Receive HDLC3 Start of Reception interrupt</p>
4	TxEOT ENB	R/W	0	<p>Transmit HDLC3 End of Transmission Interrupt Enable</p> <p>0 = Disables the Transmit HDLC3 End of Transmission interrupt</p> <p>1 = Enables the Transmit HDLC3 End of Transmission interrupt</p>
3	RxEOT ENB	R/W	0	<p>Receive HDLC3 End of Reception Interrupt Enable</p> <p>0 = Disables the Receive HDLC3 End of Reception interrupt</p> <p>1 = Enables the Receive HDLC3 End of Reception interrupt</p>
2	FCS ERR ENB	R/W	0	<p>FCS Error Interrupt Enable</p> <p>0 = Disables FCS Error interrupt</p> <p>1 = Enables FCS Error interrupt</p>

TABLE 137: DATA LINK INTERRUPT ENABLE REGISTER 3

REGISTER 551 DATA LINK INTERRUPT ENABLE REGISTER 3 (DLIER3) HEX ADDRESS: 0x0B27

BIT	FUNCTION	TYPE	DEFAULT	DESCRIPTION-OPERATION
1	RxABORT ENB	R/W	0	Receipt of Abort Sequence Interrupt Enable 0 = Disables Receipt of Abort Sequence interrupt 1 = Enables Receive of Abort Sequence interrupt
0	RxIDLE ENB	R/W	0	Receipt of Idle Sequence Interrupt Enable 0 = Disables Receipt of Idle Sequence interrupt 1 = Enables Receipt of Idle Sequence interrupt

TABLE 138: SS7 STATUS REGISTER FOR LAPD3

REGISTER 552 SS7 STATUS REGISTER FOR LAPD3 (SS7SR3) HEX ADDRESS: 0x0B28

BIT	FUNCTION	TYPE	DEFAULT	DESCRIPTION-OPERATION
0	SS7_3_STATUS	RUR	0	SS7 Interrupt Status for LAPD3 0 = No change in status 1 = Change in status has occurred

TABLE 139: SS7 ENABLE REGISTER FOR LAPD3

REGISTER 553 SS7 ENABLE REGISTER FOR LAPD3 (SS7ER3) HEX ADDRESS: 0x0B29

BIT	FUNCTION	TYPE	DEFAULT	DESCRIPTION-OPERATION
0	SS7_3_ENB	R/W	0	SS7 Interrupt Enable for LAPD3 0 = Disabled 1 = Enable SS7 interrupt generation if more than 276 bytes are received within the LAPD3 message

TABLE 140: CUSTOMER INSTALLATION ALARM STATUS REGISTER

REGISTER 554 CUSTOMER INSTALLATION ALARM STATUS REGISTER (CIASR) HEX ADDRESS: 0x0B40

BIT	FUNCTION	TYPE	DEFAULT	DESCRIPTION-OPERATION
[7:6]	Reserved	-	-	These bits are reserved
5	RxAIS-CI_state	R/W	0	Rx AIS-CI State 0 = No AIS-CI state detected 1 = AIS-CI state detected
4	RxRAI-CI_state	R/W	0	Rx RAI-CI State 0 = No RAI-CI state detected 1 = RAI-CI state detected
[3:2]	Reserved	-	-	These bits are reserved

TABLE 140: CUSTOMER INSTALLATION ALARM STATUS REGISTER**REGISTER 554****CUSTOMER INSTALLATION ALARM STATUS REGISTER (CIASR)****HEX ADDRESS: 0x0B40**

BIT	FUNCTION	TYPE	DEFAULT	DESCRIPTION-OPERATION
1	RxAIS-CI	RUR	0	Rx AIS-CI State Change 0 = No change in status 1 = Change of status has occurred
0	RxRAI-CI	RUR	0	Rx RAI-CI State Change 0 = No change in status 1 = Change of status has occurred

TABLE 141: CUSTOMER INSTALLATION ALARM STATUS REGISTER**REGISTER 555****CUSTOMER INSTALLATION ALARM INTERRUPT ENABLE REGISTER (CIAIER)****HEX ADDRESS: 0x0B41**

BIT	FUNCTION	TYPE	DEFAULT	DESCRIPTION-OPERATION
1	RxAIS-CI_ENB	R/W	0	Rx AIS-CI Interrupt Generation Enable 0 = Disabled 1 - Enable Rx AIS-CI Interrupt Generation
0	RxRAI-CI_ENB	R/W	0	Rx RAI-CI Interrupt Generation Enable 0 = Disabled 1 - Enable Rx RAI-CI Interrupt Generation

3.5 Programming the Line Interface Unit (LIU Section)

Control Registers

TABLE 142: MICROPROCESSOR REGISTER #556 BIT DESCRIPTION

REGISTER ADDRESS 0x0F00H	CHANNEL 0	FUNCTION	REGISTER TYPE	RESET VALUE
BIT #	NAME			
D7	Reserved	This Bit Is Not Used	R/W	0
D6	Reserved	This Bit Is Not Used	R/W	
D5	RXON_n	Receiver ON: Writing a “1” into this bit location turns on the Receive Section of channel n. Writing a “0” shuts off the Receiver Section of channel n.	R/W	0
D4	EQC4_n	Equalizer Control bit 4: This bit together with EQC[3:0] are used for controlling transmit pulse shaping, transmit line build-out (LBO) and receive monitoring for either T1 or E1 Modes of operation. See Table .	R/W	0
D3	EQC3_n	Equalizer Control bit 3: See bit D4 description for function of this bit	R/W	0
D2	EQC2_n	Equalizer Control bit 2: See bit D4 description for function of this bit	R/W	0
D1	EQC1_n	Equalizer Control bit 1: See bit D4 description for function of this bit	R/W	0
D0	EQC0_n	Equalizer Control bit 0: See bit D4 description for function of this bit	R/W	0

TABLE 143: EQUALIZER CONTROL AND TRANSMIT LINE BUILD OUT

EQC[4:0]	T1/E1 MODE/RECEIVE SENSITIVITY	TRANSMIT LBO	CABLE
0x00h	T1 Long Haul/36dB	0dB	100Ω TP
0x01h	T1 Long Haul/36dB	-7.5dB	100Ω TP
0x02h	T1 Long Haul/36dB	-15dB	100Ω TP
0x03h	T1 Long Haul/36dB	-22.5dB	100Ω TP
0x04h	T1 Long Haul/45dB	0dB	100Ω TP
0x05h	T1 Long Haul/45dB	-7.5dB	100Ω TP
0x06h	T1 Long Haul/45dB	-15dB	100Ω TP
0x07h	T1 Long Haul/45dB	-22.5dB	100Ω TP
0x08h	T1 Short Haul/15dB	0 to 133 feet (0.6dB)	100Ω TP
0x09h	T1 Short Haul/15dB	133 to 266 feet (1.2dB)	100Ω TP
0x0Ah	T1 Short Haul/15dB	266 to 399 feet (1.8dB)	100Ω TP
0x0Bh	T1 Short Haul/15dB	399 to 533 feet (2.4dB)	100Ω TP
0x0Ch	T1 Short Haul/15dB	533 to 655 feet (3.0dB)	100Ω TP

TABLE 143: EQUALIZER CONTROL AND TRANSMIT LINE BUILD OUT

EQC[4:0]	T1/E1 MODE/RECEIVE SENSITIVITY	TRANSMIT LBO	CABLE
0x0Dh	T1 Short Haul/15dB	Arbitrary Pulse	100Ω TP
0x0Eh	T1 Gain Mode/29dB	0 to 133 feet (0.6dB)	100Ω TP
0x0Fh	T1 Gain Mode/29dB	133 to 266 feet (1.2dB)	100Ω TP
0x10h	T1 Gain Mode/29dB	266 to 399 feet (1.8dB)	100Ω TP
0x11h	T1 Gain Mode/29dB	399 to 533 feet (2.4dB)	100Ω TP
0x12h	T1 Gain Mode/29dB	533 to 655 feet (3.0dB)	100Ω TP
0x13h	T1 Gain Mode/29dB	Arbitrary Pulse	100Ω TP
0x14h	T1 Gain Mode/29dB	0dB	100Ω TP
0x15h	T1 Gain Mode/29dB	-7.5dB	100Ω TP
0x16h	T1 Gain Mode/29dB	-15dB	100Ω TP
0x17h	T1 Gain Mode/29dB	-22.5dB	100Ω TP
0x18h	E1 Long Haul/36dB	ITU G.703	75Ω Coax
0x19h	E1 Long Haul/36dB	ITU G.703	120Ω TP
0x1Ah	E1 Long Haul/45dB	ITU G.703	75Ω Coax
0x1Bh	E1 Long Haul/45dB	ITU G.703	120Ω TP
0x1Ch	E1 Short Haul/15dB	ITU G.703	75Ω Coax
0x1Dh	E1 Short Haul/15dB	ITU G.703	120Ω TP
0x1Eh	E1 Gain Mode/29dB	ITU G.703	75Ω Coax
0x1Fh	E1 Gain Mode/29dB	ITU G.703	120Ω TP

TABLE 144: MICROPROCESSOR REGISTER #557 BIT DESCRIPTION

REGISTER ADDRESS 0x0F01H	CHANNEL_0	FUNCTION	REGISTER TYPE	RESET VALUE															
BIT #	NAME																		
D7	RXTSEL_n	<p>Receiver Termination Select: In Host mode, this bit is used to select between the internal termination and “High” impedance modes for the receiver according to the following table;</p> <table border="1"> <thead> <tr> <th>RXTSEL</th> <th>RX Termination</th> </tr> </thead> <tbody> <tr> <td>0</td> <td>“High” Impedance</td> </tr> <tr> <td>1</td> <td>Internal</td> </tr> </tbody> </table>	RXTSEL	RX Termination	0	“High” Impedance	1	Internal	R/W	0									
RXTSEL	RX Termination																		
0	“High” Impedance																		
1	Internal																		
D6	TXTSEL_n	<p>Transmit Termination Select: In Host mode, this bit is used to select between the internal termination and “High” impedance modes for the transmitter according to the following table;</p> <table border="1"> <thead> <tr> <th>TXTSEL</th> <th>TX Termination</th> </tr> </thead> <tbody> <tr> <td>0</td> <td>“High” Impedance</td> </tr> <tr> <td>1</td> <td>Internal</td> </tr> </tbody> </table>	TXTSEL	TX Termination	0	“High” Impedance	1	Internal	R/W	0									
TXTSEL	TX Termination																		
0	“High” Impedance																		
1	Internal																		
D5	TERSEL1_n	<p>Termination Impedance Select1: In Host mode and in internal termination mode, (TXTSEL = “1” and RXTSEL = “1”) TERSEL[1:0] control the transmit and receive termination impedance according to the following table;</p> <table border="1"> <thead> <tr> <th>TERSEL1</th> <th>TERSEL0</th> <th>Termination</th> </tr> </thead> <tbody> <tr> <td>0</td> <td>0</td> <td>100Ω</td> </tr> <tr> <td>0</td> <td>1</td> <td>110Ω</td> </tr> <tr> <td>1</td> <td>0</td> <td>75Ω</td> </tr> <tr> <td>1</td> <td>1</td> <td>120Ω</td> </tr> </tbody> </table> <p>In the internal termination mode, the receiver termination of each receiver is realized completely by internal resistors or by the combination of internal and one fixed external resistor. In the internal termination mode, the transmitter output should be AC coupled to the transformer.</p>	TERSEL1	TERSEL0	Termination	0	0	100Ω	0	1	110Ω	1	0	75Ω	1	1	120Ω	R/W	0
TERSEL1	TERSEL0	Termination																	
0	0	100Ω																	
0	1	110Ω																	
1	0	75Ω																	
1	1	120Ω																	
D4	TERSEL0_n	Termination Impedance Select bit 0:	R/W	0															
D3	RxJASEL_n	<p>Receive Jitter Attenuator Enable The bit is used to enable the receive jitter attenuator. “0” = Disabled “1” = Enable the Receive Jitter Attenuator</p>	R/W	0															
D2	TxJASEL_n	<p>Transmit Jitter Attenuator Enable The bit is used to enable the transmit jitter attenuator. “0” = Disabled “1” = Enable the Transmit Jitter Attenuator</p>	R/W	0															

TABLE 144: MICROPROCESSOR REGISTER #557 BIT DESCRIPTION

REGISTER ADDRESS 0x0F01H	CHANNEL_0	FUNCTION	REGISTER TYPE	RESET VALUE																																													
BIT #	NAME																																																
D1	JABW_n	<p>Jitter Attenuator Bandwidth Select: In E1 mode, set this bit to “1” to select a 1.5Hz Bandwidth for the Jitter Attenuator. The FIFO length will be automatically set to 64 bits. Set this bit to “0” to select 10Hz Bandwidth for the Jitter Attenuator in E1 mode. In T1 mode the Jitter Attenuator Bandwidth is permanently set to 3Hz, and the state of this bit has no effect on the Bandwidth.</p> <table border="1"> <thead> <tr> <th>Mode</th> <th>JABW bit D1</th> <th>FIFOS_n bit D0</th> <th>JA B-W Hz</th> <th>FIFO Size</th> </tr> </thead> <tbody> <tr> <td>T1</td> <td>0</td> <td>0</td> <td>3</td> <td>32</td> </tr> <tr> <td>T1</td> <td>0</td> <td>1</td> <td>3</td> <td>64</td> </tr> <tr> <td>T1</td> <td>1</td> <td>0</td> <td>3</td> <td>32</td> </tr> <tr> <td>T1</td> <td>1</td> <td>1</td> <td>3</td> <td>64</td> </tr> <tr> <td>E1</td> <td>0</td> <td>0</td> <td>10</td> <td>32</td> </tr> <tr> <td>E1</td> <td>0</td> <td>1</td> <td>10</td> <td>64</td> </tr> <tr> <td>E1</td> <td>1</td> <td>0</td> <td>1.5</td> <td>64</td> </tr> <tr> <td>E1</td> <td>1</td> <td>1</td> <td>1.5</td> <td>64</td> </tr> </tbody> </table>	Mode	JABW bit D1	FIFOS_n bit D0	JA B-W Hz	FIFO Size	T1	0	0	3	32	T1	0	1	3	64	T1	1	0	3	32	T1	1	1	3	64	E1	0	0	10	32	E1	0	1	10	64	E1	1	0	1.5	64	E1	1	1	1.5	64	R/W	0
Mode	JABW bit D1	FIFOS_n bit D0	JA B-W Hz	FIFO Size																																													
T1	0	0	3	32																																													
T1	0	1	3	64																																													
T1	1	0	3	32																																													
T1	1	1	3	64																																													
E1	0	0	10	32																																													
E1	0	1	10	64																																													
E1	1	0	1.5	64																																													
E1	1	1	1.5	64																																													
D0	FIFOS_n	<p>FIFO Size Select: See table of bit D1 above for the function of this bit.</p>	R/W	0																																													

TABLE 145: MICROPROCESSOR REGISTER #558 BIT DESCRIPTION

REGISTER ADDRESS 0x0F02H	CHANNEL_0	FUNCTION	REGISTER TYPE	RESET VALUE																								
BIT #	NAME																											
D7	INVQRSS_n	Invert QRSS Pattern: When TQRSS is active, Writing a “1” to this bit inverts the polarity of transmitted QRSS pattern. Writing a “0” sends the QRSS pattern with no inversion.	R/W	0																								
D6	TXTEST2_n	<p>Transmit Test Pattern bit 2: This bit together with TXTEST1 and TXTEST0 are used to generate and transmit test patterns according to the following table:</p> <table border="1" style="margin-left: 40px;"> <thead> <tr> <th>TXTEST2</th> <th>TXTEST1</th> <th>TXTEST0</th> <th>Test Pattern</th> </tr> </thead> <tbody> <tr> <td>0</td> <td>X</td> <td>X</td> <td>No Pattern</td> </tr> <tr> <td>1</td> <td>0</td> <td>0</td> <td>TDQRSS</td> </tr> <tr> <td>1</td> <td>0</td> <td>1</td> <td>TAOS</td> </tr> <tr> <td>1</td> <td>1</td> <td>0</td> <td>TLUC</td> </tr> <tr> <td>1</td> <td>1</td> <td>1</td> <td>TLDC</td> </tr> </tbody> </table> <p>TDQRSS (Transmit/Detect Quasi-Random Signal): This condition when activated enables Quasi-Random Signal Source generation and detection for the selected channel number n. In a T1 system QRSS pattern is a 2²⁰-1 pseudo-random bit sequence (PRBS) with no more than 14 consecutive zeros. In a E1 system, QRSS is a 2¹⁵-1 PRBS pattern.</p> <p>TAOS (Transmit All Ones): Activating this condition enables the transmission of an All Ones Pattern from the selected channel number n.</p> <p>TLUC (Transmit Network Loop-Up Code): Activating this condition enables the Network Loop-Up Code of “00001” to be transmitted to the line for the selected channel number n. When Network Loop-Up code is being transmitted, the XRT86L30 will ignore the Automatic Loop-Code detection and Remote Loop-Back activation (NLCDE1 =“1”, NLCDE0 =“1”, if activated) in order to avoid activating Remote Digital Loop-Back automatically when the remote terminal responds to the Loop-Back request.</p> <p>TLDC (Transmit Network Loop-Down Code): Activating this condition enables the network Loop-Down Code of “001” to be transmitted to the line for the selected channel number n.</p>	TXTEST2	TXTEST1	TXTEST0	Test Pattern	0	X	X	No Pattern	1	0	0	TDQRSS	1	0	1	TAOS	1	1	0	TLUC	1	1	1	TLDC	R/W	0
TXTEST2	TXTEST1	TXTEST0	Test Pattern																									
0	X	X	No Pattern																									
1	0	0	TDQRSS																									
1	0	1	TAOS																									
1	1	0	TLUC																									
1	1	1	TLDC																									
D5	TXTEST1_n	Transmit Test pattern bit 1: See description of bit D6 for the function of this bit.	R/W	0																								
D4	TXTEST0_n	Transmit Test Pattern bit 0: See description of bit D6 for the function of this bit.	R/W	0																								
D3	TXON_n	Transmitter ON: Writing a “1” into this bit location turns on the Transmit Section of channel n. Writing a “0” shuts off the Transmit Section of channel n. In this mode, TTIP_n and TRING_n driver outputs will be tri-stated for power reduction or redundancy applications.	R/W	0																								

TABLE 145: MICROPROCESSOR REGISTER #558 BIT DESCRIPTION

REGISTER ADDRESS 0x0F02H	CHANNEL_0 NAME	FUNCTION	REGISTER TYPE	RESET VALUE																								
D2	LOOP2_n	<p>Loop-Back control bit 2: This bit together with the LOOP1 and LOOP0 bits control the Loop-Back modes of the LIU section of the chip according to the following table:</p> <table border="1"> <thead> <tr> <th>LOOP2</th> <th>LOOP1</th> <th>LOOP0</th> <th>Loop-Back Mode</th> </tr> </thead> <tbody> <tr> <td>0</td> <td>X</td> <td>X</td> <td>No Loop-Back</td> </tr> <tr> <td>1</td> <td>0</td> <td>0</td> <td>Dual Loop-Back</td> </tr> <tr> <td>1</td> <td>0</td> <td>1</td> <td>Analog Loop-Back</td> </tr> <tr> <td>1</td> <td>1</td> <td>0</td> <td>Remote Loop-Back</td> </tr> <tr> <td>1</td> <td>1</td> <td>1</td> <td>Digital Loop-Back</td> </tr> </tbody> </table>	LOOP2	LOOP1	LOOP0	Loop-Back Mode	0	X	X	No Loop-Back	1	0	0	Dual Loop-Back	1	0	1	Analog Loop-Back	1	1	0	Remote Loop-Back	1	1	1	Digital Loop-Back		
LOOP2	LOOP1	LOOP0	Loop-Back Mode																									
0	X	X	No Loop-Back																									
1	0	0	Dual Loop-Back																									
1	0	1	Analog Loop-Back																									
1	1	0	Remote Loop-Back																									
1	1	1	Digital Loop-Back																									
D1	LOOP1_n	Loop-Back control bit 1: See description of bit D2 for the function of this bit.	R/W	0																								
D0	LOOP0_n	Loop-Back control bit 0: See description of bit D2 for the function of this bit.	R/W	0																								

TABLE 146: MICROPROCESSOR REGISTER #559 BIT DESCRIPTION

REGISTER ADDRESS 0x0F03H	CHANNEL_0	FUNCTION	REGISTER TYPE	RESET VALUE															
Bit #	NAME																		
D7	NLCDE1_n	<p>Network Loop Code Detection Enable Bit 1: This bit together with NLCDE0_n control the Loop-Code detection of each channel.</p> <table border="1"> <thead> <tr> <th>NLCDE1</th> <th>NLCDE0</th> <th>Function</th> </tr> </thead> <tbody> <tr> <td>0</td> <td>0</td> <td>Disable Loop-code detection</td> </tr> <tr> <td>0</td> <td>1</td> <td>Detect Loop-Up code in receive data</td> </tr> <tr> <td>1</td> <td>0</td> <td>Detect Loop-Down code in receive data</td> </tr> <tr> <td>1</td> <td>1</td> <td>Automatic Loop-Code detection</td> </tr> </tbody> </table> <p>When NLCDE1 = "0" and NLCDE0 = "1" or NLCDE1 = "1" and NLCDE0 = "0", the chip is manually programmed to monitor the receive data for the Loop-Up or Loop-Down code respectively. When the presence of the "00001" or "001" pattern is detected for more than 5 seconds, the status of the NLCD bit is set to "1" and if the NLCD interrupt is enabled, an interrupt is initiated. The Host has the option to control the Loop-Back function manually.</p> <p>Setting the NLCDE1 = "1" and NLCDE0 = "1" enables the Automatic Loop-Code detection and Remote Loop-Back activation mode. As this mode is initiated, the state of the NLCD interface bit is reset to "0" and the chip is programmed to monitor the receive data for the Loop-Up code. If the "00001" pattern is detected for longer than 5 seconds, the NLCD bit is set "1", Remote Loop-Back is activated and the chip is automatically programmed to monitor the receive data for the Loop-Down code. The NLCD bit stays set even after the chip stops receiving the Loop-Up code. The Remote Loop-Back condition is removed when the chip receives the Loop-Down code for more than 5 seconds or if the Automatic Loop-Code detection mode is terminated.</p>	NLCDE1	NLCDE0	Function	0	0	Disable Loop-code detection	0	1	Detect Loop-Up code in receive data	1	0	Detect Loop-Down code in receive data	1	1	Automatic Loop-Code detection	R/W	0
NLCDE1	NLCDE0	Function																	
0	0	Disable Loop-code detection																	
0	1	Detect Loop-Up code in receive data																	
1	0	Detect Loop-Down code in receive data																	
1	1	Automatic Loop-Code detection																	
D6	NLCDE0_n	<p>Network Loop Code Detection Enable Bit 0: See description of D7 for function of this bit.</p>	R/W	0															
D5	Reserved	This Bit Is Not Used	R/W	0															

TABLE 146: MICROPROCESSOR REGISTER #559 BIT DESCRIPTION

D4	RXRES1_n	Receive External Resistor Control Pin 1: In Host mode, this bit along with the RXRES0_n bit selects the value of the external Receive fixed resistor according to the following table;	R/W	0															
		<table border="1"> <tr> <th>RXRES1_n</th> <th>RXRES0_n</th> <th>Required Fixed External RX Resistor</th> </tr> <tr> <td>0</td> <td>0</td> <td>No external Fixed Resistor</td> </tr> <tr> <td>0</td> <td>1</td> <td>240Ω</td> </tr> <tr> <td>1</td> <td>0</td> <td>210Ω</td> </tr> <tr> <td>1</td> <td>1</td> <td>150Ω</td> </tr> </table>	RXRES1_n	RXRES0_n	Required Fixed External RX Resistor	0	0	No external Fixed Resistor	0	1	240Ω	1	0	210Ω	1	1	150Ω		
RXRES1_n	RXRES0_n	Required Fixed External RX Resistor																	
0	0	No external Fixed Resistor																	
0	1	240Ω																	
1	0	210Ω																	
1	1	150Ω																	
D3	RXRES0_n	Receive External Resistor Control Pin 0: For function of this bit see description of D4 the RXRES1_n bit.	R/W	0															
D2	INSBPV_n	Insert Bipolar Violation: When this bit transitions from “0” to “1”, a bipolar violation is inserted in the transmitted data stream of the selected channel number n. Bipolar violation can be inserted either in the QRSS pattern, or input data when operating in single-rail mode. The state of this bit is sampled on the rising edge of the respective TCLK_n. NOTE: To ensure the insertion of a bipolar violation, a “0” should be written in this bit location before writing a “1”.	R/W	0															
D1	INSBER_n	Insert Bit Error: With TDQRSS enabled, when this bit transitions from “0” to “1”, a bit error will be inserted in the transmitted QRSS pattern of the selected channel number n. The state of this bit is sampled on the rising edge of the respective TCLK_n. NOTE: To ensure the insertion of bit error, a “0” should be written in this bit location before writing a “1”.	R/W	0															
D0	Reserved	This Bit Is Not Used	R/W	0															

TABLE 147: MICROPROCESSOR REGISTER #560 BIT DESCRIPTION

REGISTER ADDRESS 0x0F04H	CHANNEL_0	FUNCTION	REGISTER TYPE	RESET VALUE
Bit #	NAME			
D7	Reserved	This Bit Is Not Used	RO	0
D6	DMOIE_n	DMO Interrupt Enable: Writing a “1” to this bit enables DMO interrupt generation, writing a “0” masks it.	R/W	0
D5	FLSIE_n	FIFO Limit Status Interrupt Enable: Writing a “1” to this bit enables interrupt generation when the FIFO limit is within to 3 bits, writing a “0” to masks it.	R/W	0
D4	LCVIE_n	Line Code Violation Interrupt Enable: Writing a “1” to this bit enables Line Code Violation interrupt generation, writing a “0” masks it.	R/W	0

TABLE 147: MICROPROCESSOR REGISTER #560 BIT DESCRIPTION

D3	NLCDIE_n	Network Loop-Code Detection Interrupt Enable: Writing a “1” to this bit enables Network Loop-code detection interrupt generation, writing a “0” masks it.	R/W	0
D2	AISDIE_n	AIS Interrupt Enable: Writing a “1” to this bit enables Alarm Indication Signal detection interrupt generation, writing a “0” masks it.	R/W	0
D1	RLOSIE_n	Receive Loss of Signal Interrupt Enable: Writing a “1” to this bit enables Loss of Receive Signal interrupt generation, writing a “0” masks it.	R/W	0
D0	QRPDIE_n	QRSS Pattern Detection Interrupt Enable: Writing a “1” to this bit enables QRSS pattern detection interrupt generation, writing a “0” masks it.	R/W	0

TABLE 148: MICROPROCESSOR REGISTER #561 BIT DESCRIPTION

REGISTER ADDRESS 0x0F05H	CHANNEL_0	FUNCTION	REGISTER TYPE	RESET VALUE
Bit #	NAME			
D7	Reserved		RO	0
D6	DMO_n	Driver Monitor Output: This bit is set to a “1” to indicate transmit driver failure is detected. The value of this bit is based on the current status of DMO for the corresponding channel. If the DMOIE bit is enabled, any transition on this bit will generate an Interrupt.	RO	0
D5	FLS_n	FIFO Limit Status: This bit is set to a “1” to indicate that the jitter attenuator read/write FIFO pointers are within +/- 3 bits. If the FLSIE bit is enabled, any transition on this bit will generate an Interrupt.	RO	0
D4	LCV_n	Line Code Violation: This bit is set to a “1” to indicate that the receiver of channel n is currently detecting a Line Code Violation or an excessive number of zeros in the B8ZS or HDB3 modes. If the LCVIE bit is enabled, any transition on this bit will generate an Interrupt.	RO	0

TABLE 148: MICROPROCESSOR REGISTER #561 BIT DESCRIPTION

D3	NLCD_n	<p>Network Loop-Code Detection: This bit operates differently in the Manual or the Automatic Network Loop-Code detection modes.</p> <p>In the Manual Loop-Code detection mode, (NLCDE1 = “0” and NLCDE0 = “1” or NLCDE1 = “1” and NLCDE0 = “0”) this bit gets set to “1” as soon as the Loop-Up (“00001”) or Loop-Down (“001”) code is detected in the receive data for longer than 5 seconds. The NLCD bit stays in the “1” state for as long as the chip detects the presence of the Loop-code in the receive data and it is reset to “0” as soon as it stops receiving it. In this mode, if the NLCD interrupt is enabled, the chip will initiate an interrupt on every transition of the NLCD.</p> <p>When the Automatic Loop-code detection mode, (NLCDE1 = “1” and NLCDE0 = “1”) is initiated, the state of the NLCD interface bit is reset to “0” and the chip is programmed to monitor the receive input data for the Loop-Up code. This bit is set to a “1” to indicate that the Network Loop Code is detected for more than 5 seconds. Simultaneously the Remote Loop-Back condition is automatically activated and the chip is programmed to monitor the receive data for the Network Loop Down code. The NLCD bit stays in the “1” state for as long as the Remote Loop-Back condition is in effect even if the chip stops receiving the Loop-Up code. Remote Loop-Back is removed if the chip detects the “001” pattern for longer than 5 seconds in the receive data. Detecting the “001” pattern also results in resetting the NLCD interface bit and initiating an interrupt provided the NLCD interrupt enable bit is active.</p> <p>When programmed in Automatic detection mode, the NLCD interface bit stays “High” for the entire time the Remote Loop-Back is active and initiate an interrupt anytime the status of the NLCD bit changes. In this mode, the Host can monitor the state of the NLCD bit to determine if the Remote Loop-Back is activated.</p>	RO	0
D2	AISD_n	<p>Alarm Indication Signal Detect: This bit is set to a “1” to indicate All Ones Signal is detected by the receiver. The value of this bit is based on the current status of Alarm Indication Signal detector of channel n. If the AISDIE bit is enabled, any transition on this bit will generate an Interrupt.</p>	RO	0
D1	RLOS_n	<p>Receive Loss of Signal: This bit is set to a “1” to indicate that the receive input signal is lost. The value of this bit is based on the current status of the receive input signal of channel n. If the RLOSIE bit is enabled, any transition on this bit will generate an Interrupt.</p>	RO	0
D0	QRPD_n	<p>Quasi-random Pattern Detection: This bit is set to a “1” to indicate the receiver is currently in synchronization with QRSS pattern. The value of this bit is based on the current status of Quasi-random pattern detector of channel n. If the QRPDIE bit is enabled, any transition on this bit will generate an Interrupt.</p>	RO	0

TABLE 149: MICROPROCESSOR REGISTER #562 BIT DESCRIPTION

REGISTER ADDRESS 0x0F06H	CHANNEL_0	FUNCTION	REGISTER TYPE	RESET VALUE
Bit #	NAME			
D7	Reserved		RO	0
D6	DMOIS_n	Driver Monitor Output Interrupt Status: This bit is set to a “1” every time the DMO status has changed since last read. <i>NOTE: This bit is reset upon read.</i>	RUR	0
D5	FLSIS_n	FIFO Limit Interrupt Status: This bit is set to a “1” every time when FIFO Limit (Read/Write pointer with +/- 3 bits apart) status has changed since last read. <i>NOTE: This bit is reset upon read.</i>	RUR	0
D4	LCVIS_n	Line Code Violation Interrupt Status: This bit is set to a “1” every time when LCV status has changed since last read. <i>NOTE: This bit is reset upon read.</i>	RUR	0
D3	NLCDIS_n	Network Loop-Code Detection Interrupt Status: This bit is set to a “1” every time when NLCD status has changed since last read. <i>NOTE: This bit is reset upon read.</i>	RUR	0
D2	AISDIS_n	AIS Detection Interrupt Status: This bit is set to a “1” every time when AISD status has changed since last read. <i>NOTE: This bit is reset upon read.</i>	RUR	0
D1	RLOSIS_n	Receive Loss of Signal Interrupt Status: This bit is set to a “1” every time RLOS status has changed since last read. <i>NOTE: This bit is reset upon read.</i>	RUR	0
D0	QRPDIS_n	Quasi-Random Pattern Detection Interrupt Status: This bit is set to a “1” every time when QRPD status has changed since last read. <i>NOTE: This bit is reset upon read.</i>	RUR	0

TABLE 150: MICROPROCESSOR REGISTER #563 BIT DESCRIPTION

REGISTER ADDRESS 0x0F07H	CHANNEL_0	FUNCTION	REGISTER TYPE	RESET VALUE
Bit #	NAME			
D7	Reserved		RO	0
D6	Reserved		RO	0
D5	CLOS5_n	Cable Loss bit 5: CLOS[5:0]_n are the six bit receive selective equalizer setting which is also a binary word that represents the cable attenuation indication within ± 1 dB. CLOS5_n is the most significant bit (MSB) and CLOS0_n is the least significant bit (LSB).	RO	0
D4	CLOS4_n	Cable Loss bit 4: See description of D5 for function of this bit.	RO	0
D3	CLOS3_n	Cable Loss bit 3: See description of D5 for function of this bit.	RO	0

TABLE 150: MICROPROCESSOR REGISTER #563 BIT DESCRIPTION

D2	CLOS2_n	Cable Loss bit 2: See description of D5 for function of this bit.	RO	0
D1	CLOS1_n	Cable Loss bit 1: See description of D5 for function of this bit.	RO	0
D0	CLOS0_n	Cable Loss bit 0: See description of D5 for function of this bit.	RO	0

TABLE 151: MICROPROCESSOR REGISTER #564 BIT DESCRIPTION

REGISTER ADDRESS 0x0F08H	CHANNEL_0	FUNCTION	REGISTER TYPE	RESET VALUE
Bit #	NAME			
D7	Reserved		R/W	0
D6-D0	B6S1_n - B0S1_n	Arbitrary Transmit Pulse Shape, Segment 1: The shape of each channel's transmitted pulse can be made independently user programmable by selecting "Arbitrary Pulse" mode. The arbitrary pulse is divided into eight time segments whose combined duration is equal to one period of MCLK. This 7 bit number represents the amplitude of the nth channel's arbitrary pulse during the first time segment. B6S1_n-B0S1_n is in signed magnitude format with B6S1_n as the sign bit and B0S1_n as the least significant bit (LSB).	R/W	0

TABLE 152: MICROPROCESSOR REGISTER #565 BIT DESCRIPTION

REGISTER ADDRESS 0x0F09H	CHANNEL_0	FUNCTION	REGISTER TYPE	RESET VALUE
Bit #	NAME			
D7	Reserved		R/W	0
D6-D0	B6S2_n - B0S2_n	Arbitrary Transmit Pulse Shape, Segment 2 The shape of each channel's transmitted pulse can be made independently user programmable by selecting "Arbitrary Pulse" mode. The arbitrary pulse is divided into eight time segments whose combined duration is equal to one period of MCLK. This 7 bit number represents the amplitude of the nth channel's arbitrary pulse during the second time segment. B6S2_n-B0S2_n is in signed magnitude format with B6S2_n as the sign bit and B0S2_n as the least significant bit (LSB).	R/W	0

TABLE 153: MICROPROCESSOR REGISTER #566 BIT DESCRIPTION

REGISTER ADDRESS 0x0F0Ah	CHANNEL_0	FUNCTION	REGISTER TYPE	RESET VALUE
Bit #	NAME			
D7	Reserved		R/W	0
D6-D0	B6S3_n - B0S3_n	<p>Arbitrary Transmit Pulse Shape, Segment 3</p> <p>The shape of each channel's transmitted pulse can be made independently user programmable by selecting "Arbitrary Pulse" mode. The arbitrary pulse is divided into eight time segments whose combined duration is equal to one period of MCLK.</p> <p>This 7 bit number represents the amplitude of the nth channel's arbitrary pulse during the third time segment. B6S3_n-B0S3_n is in signed magnitude format with B6S3_n as the sign bit and B0S3_n as the least significant bit (LSB).</p>	R/W	0

TABLE 154: MICROPROCESSOR REGISTER #567 BIT DESCRIPTION

REGISTER ADDRESS 0x0F0Bh	CHANNEL_0	FUNCTION	REGISTER TYPE	RESET VALUE
Bit #	NAME			
D7	Reserved		R/W	0
D6-D0	B6S4_n - B0S4_n	<p>Arbitrary Transmit Pulse Shape, Segment 4</p> <p>The shape of each channel's transmitted pulse can be made independently user programmable by selecting "Arbitrary Pulse" mode. The arbitrary pulse is divided into eight time segments whose combined duration is equal to one period of MCLK.</p> <p>This 7 bit number represents the amplitude of the nth channel's arbitrary pulse during the fourth time segment. B6S4_n-B0S4_n is in signed magnitude format with B6S4_n as the sign bit and B0S4_n as the least significant bit (LSB).</p>	R/W	0

TABLE 155: MICROPROCESSOR REGISTER #568 BIT DESCRIPTION

REGISTER ADDRESS 0x0F0Ch	CHANNEL_0	FUNCTION	REGISTER TYPE	RESET VALUE
Bit #	NAME			
D7	Reserved		R/W	0
D6-D0	B6S5_n - B0S5_n	<p>Arbitrary Transmit Pulse Shape, Segment 5</p> <p>The shape of each channel's transmitted pulse can be made independently user programmable by selecting "Arbitrary Pulse" mode. The arbitrary pulse is divided into eight time segments whose combined duration is equal to one period of MCLK.</p> <p>This 7 bit number represents the amplitude of the nth channel's arbitrary pulse during the fifth time segment. B6S5_n-B0S5_n is in signed magnitude format with B6S5_n as the sign bit and B0S5_n as the least significant bit (LSB).</p>	R/W	0

TABLE 156: MICROPROCESSOR REGISTER #569 BIT DESCRIPTION

REGISTER ADDRESS 0x0F0Dh	CHANNEL_0	FUNCTION	REGISTER TYPE	RESET VALUE
Bit #	NAME			
D7	Reserved		R/W	0
D6-D0	B6S6_n - B0S6_n	<p>Arbitrary Transmit Pulse Shape, Segment 6</p> <p>The shape of each channel's transmitted pulse can be made independently user programmable by selecting "Arbitrary Pulse" mode. The arbitrary pulse is divided into eight time segments whose combined duration is equal to one period of MCLK.</p> <p>This 7 bit number represents the amplitude of the nth channel's arbitrary pulse during the sixth time segment. B6S6_n-B0S6_n is in signed magnitude format with B6S6_n as the sign bit and B0S6_n as the least significant bit (LSB).</p>	R/W	0

TABLE 157: MICROPROCESSOR REGISTER #570 BIT DESCRIPTION

REGISTER ADDRESS 0x0F0EH	CHANNEL_0	FUNCTION	REGISTER TYPE	RESET VALUE
Bit #	NAME			
D7	Reserved		R/W	0
D6-D0	B6S7_n - B0S7_n	<p>Arbitrary Transmit Pulse Shape, Segment 7</p> <p>The shape of each channel's transmitted pulse can be made independently user programmable by selecting "Arbitrary Pulse" mode. The arbitrary pulse is divided into eight time segments whose combined duration is equal to one period of MCLK.</p> <p>This 7 bit number represents the amplitude of the nth channel's arbitrary pulse during the seventh time segment. B6S7_n-B0S7_n is in signed magnitude format with B6S7_n as the sign bit and B0S7_n as the least significant bit (LSB).</p>	R/W	0

TABLE 158: MICROPROCESSOR REGISTER #571 BIT DESCRIPTION

REGISTER ADDRESS 0x0F0FH	CHANNEL_0	FUNCTION	REGISTER TYPE	RESET VALUE
Bit #	NAME			
D7	Reserved		R/W	0
D6-D0	B6S8_n - B0S8_n	<p>Arbitrary Transmit Pulse Shape, Segment 8</p> <p>The shape of each channel's transmitted pulse can be made independently user programmable by selecting "Arbitrary Pulse" mode. The arbitrary pulse is divided into eight time segments whose combined duration is equal to one period of MCLK.</p> <p>This 7 bit number represents the amplitude of the nth channel's arbitrary pulse during the eighth time segment. B6S8_n-B0S8_n is in signed magnitude format with B6S8_n as the sign bit and B0S8_n as the least significant bit (LSB).</p>	R/W	0

Global Control Registers

TABLE 159: MICROPROCESSOR REGISTER #700 BIT DESCRIPTION - GLOBAL REGISTER 0

REGISTER ADDRESS 0x0FE0h	NAME	FUNCTION	REGISTER TYPE	RESET VALUE
Bit #				
D7	Reserved	This Bit Is Not Used	R/W	0
D6	ATAOS	Automatic Transmit All Ones Upon RLOS: Writing a "1" to this bit enables the automatic transmission of All "Ones" data to the line for the channel that detects an RLOS condition. Writing a "0" disables this feature.	R/W	0
D5	Reserved	This Bit Is Not Used	R/W	0
D4	Reserved	This Bit Is Not Used	R/W	0
D3	Reserved	This Bit Is Not Used	R/W	0
D2	Reserved	This Bit Is Not Used		0
D1	GIE	Global Interrupt Enable: Writing a "1" to this bit globally enables interrupt generation for all channels. Writing a "0" disables interrupt generation.	R/W	0
D0	SRESET	Software Reset μP Registers: Writing a "1" to this bit longer than 10 μ s initiates a device reset through the microprocessor interface. All internal circuits are placed in the reset state with this bit set to a "1" except the microprocessor register bits.	R/W	0

TABLE 160: MICROPROCESSOR REGISTER #701, BIT DESCRIPTION - GLOBAL REGISTER 1

REGISTER ADDRESS 0x0FE1h	NAME	FUNCTION	REGISTER TYPE	RESET VALUE															
Bit #																			
D7	Reserved		R/W	0															
D6	Reserved		R/W	0															
D5 D4	Gauge1 Gauge0	Wire Gauge Selector Bit 1: This bit together with bit D6 are used to select wire gauge size as shown in the table below. <table border="1" style="margin-left: auto; margin-right: auto;"> <thead> <tr> <th>GAUGE1</th> <th>GAUGE0</th> <th>Wire Size</th> </tr> </thead> <tbody> <tr> <td>0</td> <td>0</td> <td>22 and 24 Gauge</td> </tr> <tr> <td>0</td> <td>1</td> <td>22 Gauge</td> </tr> <tr> <td>1</td> <td>0</td> <td>24 Gauge</td> </tr> <tr> <td>1</td> <td>1</td> <td>26 Gauge</td> </tr> </tbody> </table>	GAUGE1	GAUGE0	Wire Size	0	0	22 and 24 Gauge	0	1	22 Gauge	1	0	24 Gauge	1	1	26 Gauge	R/W	0 0
GAUGE1	GAUGE0	Wire Size																	
0	0	22 and 24 Gauge																	
0	1	22 Gauge																	
1	0	24 Gauge																	
1	1	26 Gauge																	
D3	Reserved	This Bit Is Not Used	R/W	0															

TABLE 160: MICROPROCESSOR REGISTER #701, BIT DESCRIPTION - GLOBAL REGISTER 1

D2	RXMUTE	Receive Output Mute: Writing a “1” to this bit, mutes receive outputs at the framer block to a “0” state for any channel that detects an RLOS condition. <i>NOTE: The receive clock is not muted.</i>	R/W	0
D1	EXLOS	Extended LOS: Writing a “1” to this bit extends the number of zeros at the receive input of each channel before RLOS is declared to 4096 bits. Writing a “0” reverts to the normal mode (175+75 bits for T1 and 32 bits for E1).	R/W	0
D0	ICT	In-Circuit-Testing: Writing a “1” to this bit configures all the output pins of the chip in high impedance mode for In-Circuit-Testing.	R/W	0

TABLE 161: MICROPROCESSOR REGISTER #702, BIT DESCRIPTION - GLOBAL REGISTER 2

REGISTER ADDRESS 0x0FE2h	NAME	FUNCTION	REGISTER TYPE	RESET VALUE
Bit #				
D7	Reserved	This Bit Is Not Used	R/W	0
D6	Reserved	This Bit Is Not Used	R/W	0
D5-D0	Reserved	This Bit Is Not Used	R/W	0

TABLE 162: MICROPROCESSOR REGISTER #703, BIT DESCRIPTION - GLOBAL REGISTER 3

REGISTER ADDRESS 0x0FE4h	NAME	FUNCTION	REGISTER TYPE	RESET VALUE
Bit #				
D7 D6	MCLKnT11 MCLKnT10	Master T1 Output Clock Reference These two bits are used to select the programmable output clock reference for T1MCLKnOUT. “00” = 1.544MHz “01” = 3.088MHz “10” = 6.176MHz “11” = 12.352MHz	R/W	0 0
D5 D4	MCLKnE11 MCLKnE10	Master E1 Output Clock Reference These two bits are used to select the programmable output clock reference for E1MCLKnOUT. “00” = 2.048MHz “01” = 4.096MHz “10” = 8.192MHz “11” = 16.384MHz	R/W	0 0
D3	Reserved	This Bit Is Not Used.	R/W	0
D2	Reserved	This Bit Is Not Used.	R/W	0

TABLE 162: MICROPROCESSOR REGISTER #703, BIT DESCRIPTION - GLOBAL REGISTER 3

D1	Reserved	This Bit Is Not Used.	R/W	0
D0	Reserved	This Bit Is Not Used.	R/W	0

TABLE 163: MICROPROCESSOR REGISTER #704, BIT DESCRIPTION - GLOBAL REGISTER 4

REGISTER ADDRESS 0x0FE9h	NAME	FUNCTION	REGISTER TYPE	RESET VALUE	
Bit #					
D7	Reserved	This Bit Is Not Used.	R/W	0	
D6	Reserved	This Bit Is Not Used.	R/W	0	
D5	Reserved	This Bit Is Not Used.	R/W	0	
D4	Reserved	This Bit Is Not Used.	R/W	0	
D3	CLKSEL3	Clock Select Input	R/W	0	
D2	CLKSEL2	CLKSEL[3:0] is used to select the input clock source to be used as the internal timing reference for MCLKIN.		0	
D1	CLKSEL1			0	
D0	CLKSEL0			"0000" = 2.048MHz	0
				"0001" = 1.544MHz	
			"0010" = 8kHz		
		"0011" = 16kHz			
		"0100" = 56kHz			
		"0101" = 64kHz			
		"0110" = 128kHz			
		"0111" = 256kHz			
		"1000" = 4.096MHz			
		"1001" = 3.088MHz			
		"1010" = 8.192MHz			
		"1011" = 6.176MHz			
		"1100" = 16.384MHz			
		"1101" = 12.352MHz			
		"1110" = 2.048MHz			
		"1111" = 1.544MHz			

3.6 The Interrupt Structure within the Framer

The XRT86L30 Framer is equipped with a sophisticated Interrupt Servicing Structure. This Interrupt Structure includes an Interrupt Request output pin INT, numerous Interrupt Enable Registers and numerous Interrupt Status Registers.

The Interrupt Servicing Structure, within the XRT86L30 Framer contains three levels of hierarchy:

- The Framer Level
- The Block Level
- The Source Level.

The Framer Interrupt Structure has been carefully designed to allow the user to quickly determine the exact source of this interrupt (with minimal latency) which will aid the mC/mP in determining the which interrupt service routine to call up in order to eliminate or properly respond to the condition(s) causing the interrupt.

The XRT86L30 Framer comes equipped with registers to support the servicing of this wide array of potential "interrupt request" sources. **Table 164** lists the possible conditions that can generate interrupts.

TABLE 164: LIST OF THE POSSIBLE CONDITIONS THAT CAN GENERATE INTERRUPTS, IN EACH FRAMER

INTERRUPT BLOCK	INTERRUPTING CONDITION
Framer Level	Loss of RxLineClk Signal· One Second Interrupt
HDLC Controller Block	Transmit HDLC - Start of Transmission Receive HDLC - Start of Reception Transmit HDLC - End of Transmission Receive HDLC - End of Reception FCS Error Receipt of Abort Sequence Receipt of Idle Sequence
Slip Buffer Block	Slip Buffer Full Slip Buffer Empty Slip Buffer - Slip
Alarm & Error Block	Receipt of CAS Multi-frame Yellow Alarm Detection of Loss of Signal Condition Detection of Line Code Violation Change in Receive Loss of Framer Condition Change in Receive AIS Condition Receipt of FAS Frame Yellow Alarm
T1/E1 Frame Block	Change in CAS Multi-Frame Alignment Change in National Bits· Change in CAS Signaling Bits Change in FAS Frame Alignment· Change in the "In Frame" Condition Detection of "Frame Mimicking Data" Detection of Sync (CRC-4/CRC-6) Errors Detection of Framing Bit Errors

General Flow of Interrupt Servicing

When any of the conditions presented in **Table 164** occur, (if their Interrupt is enabled), then the Framer generates an interrupt request to the mP/mC by asserting the active-low interrupt request output pin, INT. Shortly after the local mC/mP has detected the activated INT signal, it will enter into the appropriate user-supplied interrupt service routine. The first task for the mP/mC, while running this interrupt service routine, may be to isolate the source of the interrupt request down to the device level (e.g, the Framer IC), if multiple peripheral ICs exist in the user's system. However, once the interrupting peripheral device has been identified,

the next task for the mP/mC is to determine exactly what feature of functional section within the device requested the interrupt.

Determine the Framer(s) Requesting the Interrupt

If the interrupting device turns out to be the Framer, then the mP/mC must determine which of the four framer channels requested the interrupt. Hence, upon reaching this state, one of the very first things that the mP/mC must do within the user Framer interrupt service routine, is to perform a read of each of the Block Interrupt Status Registers within all of the Framer channels that have been enabled for Interrupt Generation via their respective Interrupt Control Registers.

Table 165 lists the Address for the Block Interrupt Status Registers associated with each of the Framer channels within the Framer.

TABLE 165: ADDRESS OF THE BLOCK INTERRUPT STATUS REGISTERS

FRAMER NUMBER	ADDRESS OF BLOCK INTERRUPT STATUS REGISTER
0	0x0B02
1	0x1B02
2	0x2B02
3	0x3B02
4	0x4B02
5	0x5B02
6	0x6B02
7	0x7B02

The bit-format of each of these Block Interrupt Status Registers is listed below.

TABLE 166: BLOCK INTERRUPT STATUS REGISTER

REGISTER 321

BLOCK INTERRUPT STATUS REGISTER (BISR)

HEX ADDRESS: 0x0B00

BIT	FUNCTION	TYPE	DEFAULT	DESCRIPTION-OPERATION
7	Sa6	RO	0	Sa6 Interrupt Status
7-6	LBCODE	RO	0	Loopback Code Interrupt
5	RxCikLOS	RUR	0	RxCik Los Interrupt Status Indicates if Framer n has experienced a Loss of Recovered Clock interrupt since last read of this register. 0 = Loss of Recovered Clock interrupt has not occurred since last read of this register 1 = Loss of Recovered Clock interrupt has occurred since last read of this register.

TABLE 166: BLOCK INTERRUPT STATUS REGISTER

REGISTER 321

BLOCK INTERRUPT STATUS REGISTER (BISR)

HEX ADDRESS: 0x0B00

BIT	FUNCTION	TYPE	DEFAULT	DESCRIPTION-OPERATION
4	ONESEC	RUR	0	One Second Interrupt Status Indicates if the XRT86L30 has experienced a One Second interrupt since the last read of this register. 0 = No outstanding One Second interrupts awaiting service 1 = Outstanding One Second interrupt awaits service
3	HDLC	RO	0	HDLC Block Interrupt Status Indicates if the HDLC block has an interrupt request awaiting service. 0 = No outstanding interrupt requests awaiting service 1 = HDLC Block has an interrupt request awaiting service. Interrupt Service routine should branch to and read Data Link Status Register (address xA,06). NOTE: This bit-field will be reset to 0 after the microprocessor has performed a read to the Data Link Status Register.
2	SLIP	RO	0	Slip Buffer Block Interrupt Status Indicates if the Slip Buffer block has any outstanding interrupt requests awaiting service. 0 = No outstanding interrupts awaiting service 1 = Slip Buffer block has an interrupt awaiting service. Interrupt Service routine should branch to and read Slip Buffer Interrupt Status register (address 0xXA,0x09). NOTE: This bit-field will be reset to 0 after the microprocessor has performed a read of the Slip Buffer Interrupt Status Register.
1	ALARM	RO	0	Alarm & Error Block Interrupt Status Indicates if the Alarm & Error Block has any outstanding interrupts that are awaiting service. 0 = No outstanding interrupts awaiting service 1 = Alarm & Error Block has an interrupt awaiting service. Interrupt SerStatus Register (address xA,02) NOTE: This bit-field will be reset to 0 after the microprocessor has performed a read of the Alarm & Error Interrupt Status register.
0	T1/E1 FRAME	RO	0	T1/E1 Framer Block Interrupt Status Indicates if an T1/E1 Frame Status interrupt request is awaiting service. 0 = No T1/E1 Frame Status interrupt is pending 1 = T1/E1 Framer Status interrupt is awaiting service.

For a given Framer, the Block Interrupt Status Register presents the "Interrupt Request" status of each "Interrupt Block" within the Framer. The purpose of the "Block Interrupt Status Register" is to help the mP/mC identify which "Interrupt Block(s) have requested the interrupt. Whichever bit(s) are asserted, in this register, identifies which block(s) have experienced an "interrupt generating" condition, as presented in [Table 166](#). Once the mP/mC has read this register, it can determine which "branch" within the interrupt service routine that it must follow; in order to properly service this interrupt.

The Framer IC further supports the "Interrupt Block" Hierarchy by providing the "Block Interrupt Enable Register. The bit-format of this register is identical to that for the "Block Interrupt Status Register", and is presented below for the sake of completeness.

TABLE 167: BLOCK INTERRUPT ENABLE REGISTER
REGISTER 322
BLOCK INTERRUPT ENABLE REGISTER (BIER)
HEX ADDRESS: 0x0B01

BIT	FUNCTION	TYPE	DEFAULT	DESCRIPTION-OPERATION
7	SA6_ENB	R/W	0	SA6 interrupt enable
6	LBCODE_ENB	R/W	0	Loopback code interrupt enable
5	RXCLKLOSS	R/W	0	RxLineClk Loss Interrupt Enable 0 = Disables interrupt 1 = Enables interrupt
4	ONESEC_ENB	R/W	0	One Second Interrupt Enable 0 = Disables interrupt 1 = Enables Interrupt
3	HDLC_ENB	R/W	0	HDLC Block Interrupt Enable 0 = Disables all HDLC Block interrupts 1 = Enables HDLC Block (for interrupt generation) at the block level
2	SLIP_ENB	R/W	0	Slip Buffer Block Interrupt Enable 0 = Disables all Slip Buffer Block Interrupts 1 = Enables Slip Buffer Block at the block level
1	ALARM_ENB	R/W	0	Alarm & Error Block Interrupt Enable 0 = Disables all Alarm & Error Block interrupts 1 = Enables Alarm & Error block at the block level
0	T1/E1FRAME_ENB	R/W	0	T1/E1 Frame Block Enable 0 = Disables all Frame Block interrupts 1 = Enables the Frame Block at the block level

The Block Interrupt Enable Register permits the user to individually enable or disable the interrupt requesting capability of each of the "interrupt blocks" within the Framer. If a particular bit-field, within this register contains the value "0"; then the corresponding functional block has been disabled from generating any interrupt requests.

The procedures for configuring, enabling and servicing interrupts for each of these hierarchical levels is discussed below.

3.6.1 Configuring the Interrupt System, at the Framer Level

The XRT86L30 Framer IC permits the user to enable or disable each of the four Framers for interrupt generation. Further, the chip permits the user to make the following configuration selection.

1. Whether the "source-level" Interrupt Status bits are "Reset-upon-Read" or "Write-to-Clear".
2. Whether or not an "activated interrupt" is automatically cleared.

3.6.1.1 Enabling/Disabling the Framer for Interrupt Generation

Each of the four Framers of the XRT86L30 Framer can be enabled or disabled for interrupt generation. This selection is made by writing the appropriate "0" or "1" to bit 0 (INTRUP_EN) of the "Interrupt Control Register" corresponding to that framer, (see [Table 168.](#))

TABLE 168: INTERRUPT CONTROL REGISTER

REGISTER 26	INTERRUPT CONTROL REGISTER (ICR)				HEX ADDRESS: 0x011A
BIT	MOD E	FUNCTION	TYPE	DEFAULT	DESCRIPTION-OPERATION
7-3		Reserved	-	-	Reserved
2		INT_WC_RUR	R/W	0	Interrupt Write-to-Clear or Reset-upon-Read Select Configures Interrupt Status bits to either RUR or Write-to-Clear 0=Interrupt Status bit RUR 1=Interrupt Status bit Write-to-Clear
1		ENBCLR	R/W	0	Interrupt Enable Auto Clear 0=Interrupt Enable bits are not cleared after status reading 1=Interrupt Enable bits are cleared after status reading
0		INTRUP_ENB	R/W	0	Interrupt Enable for Framer_n Enables Framer n for Interrupt Generation. 0 = Disables corresponding framer block for Interrupt Generation 1 = Enables corresponding framer block for Interrupt Generation

Setting this bit-field to "0" disables all interrupts within the Framer. Setting this bit-field to "1" enables the Framer for interrupt generation (at the Framer Level).

NOTE: It is important to note that setting this bit-field to "1" does not enable all of the interrupts within the Framer. A given interrupt must also be enabled at the block and source-level, before it is enabled for interrupt generation.

3.6.1.2 Configuring the "Interrupt Status Bits", within a given Framer to be "Reset-upon-Read" or "Write-to-Clear".

The XRT86L30 Source-Level Interrupt Status Register bits can be configured to be either "Reset-upon-Read" or "Write-to-Clear". If the user configures the Interrupt Status Registers to be "Reset-upon-Read", then when the mP/mC is reading the interrupt status register, the following will happen.

1. The contents of the Source-Level Interrupt Status Register will automatically be reset to "0x00", following the read operation.
2. The Interrupt Request Output pin ($\overline{\text{INT}}$) will automatically toggle false (or "high") upon reading the Interrupt Status Register containing the last activated interrupt status bit.

If the user configures the Interrupt Status Registers to be "Write-to-Clear", then when the mP/mC is reading the interrupt status register, the following will happen.

1. The contents of the Source-Level Interrupt Status Register will not be cleared to "0x00", following the read operation. The mP/mC will have to write 0x00 to the interrupt status register in order to reset the contents of the register to 0x00.
2. Reading the Interrupt Status Register, which contains the activated bit(s) will not cause the "Interrupt Request Output" pin ($\overline{\text{INT}}$) to toggle false. The Interrupt Request Output pin will not toggle false until the mP/mC has written 0x00 into this register. (Hence, the Interrupt Service Routine must include this write operation).

The Interrupt Status Register (associated with a given framer) can be configured to be either "Reset-upon-Read" or "Write-to-Clear" by writing the appropriate value into Bit 2, within the Interrupt Control Register as indicated in [Table 168](#).

Writing a "0" into this bit-field configures the Interrupt Status registers to be "Reset-upon-Read" (RUR). Conversely, writing a "1" into this bit-field configures the Interrupt Status registers to be "Write-to-Clear".

3.6.1.3 Automatic Reset of Interrupt Enable Bits

Occasionally, the user's system (which includes the Framer IC), may experience a fault condition, such that a "Framer Interrupt Condition" will continuously exist. If this particular interrupt has been enabled (within the

Framer), then the Framer will generate an interrupt request to the mP/mC. Afterwards, the mP/mC will attempt to service this interrupt by reading the appropriate Block-level and Source-Level Interrupt Status Register. Additionally, the local mP/mC will attempt to perform some "system-related" tasks in order to try to resolve these conditions causing the interrupt. After the local mC/mP has attempted all of these things, the Framer IC will negate the $\overline{\text{INT}}$ output pin. However, because this system fault still remains, the condition causing the Framer to issue this interrupt also exists. Consequently, the Framer IC will generate another interrupt request, which forces the mP/mC to once again attempt to service this interrupt. This phenomenon quickly results in the local mP/mC being "tied up" in a continuous cycle of executing this one interrupt service routine. Consequently, the mP/mC (along with portions of the overall system) now becomes non-functional.

In order to prevent this phenomenon from ever occurring, the Framer IC can be configured to automatically reset the "interrupt enable" bits, following their activation. This feature can be implemented by writing the appropriate value to bit 1 of the "Interrupt Control Register" as indicated in [Table 168](#).

Writing a "1" to this bit-field configures the Framer to reset a given interrupt following activation. Writing a "0" to this bit-field configures the Framer to leave the interrupt enabled, following its activation.

4.0 GENERAL DESCRIPTION AND INTERFACE

The XRT86L30 supports multiple interfaces for various modes of operation. The purpose of this section is to present a general overview of the common interfaces and their connection diagrams. Each mode will be described in full detail in later sections of the datasheet.

NOTE: For a brief tutorial on Framing Formats, see Appendix A in the back of the datasheet.

4.1 Physical Interface

The Line Interface Unit generates/receives standard return-to-zero (RZ) signals to the line interface for T1/E1/J1 twisted pair or E1 coaxial cable. The physical interface is optimized by placing the terminating impedance inside the LIU. This allows one bill of materials for all modes of operation reducing the number of external components necessary in system design. The transmitter outputs only require one DC blocking capacitor of 0.68 μ F and a 1:2 step-up transformer. The receive path inputs only require one bypass capacitor of 0.1 μ F connected to the center tap (CT) of the transformer and a 1:1 transformer. The receive CT bypass capacitor is required for Long Haul Applications, and recommended for Short Haul Applications. **Figure 7** shows the typical connection diagram for the LIU transmitters. **Figure 8** shows a typical connection diagram for the LIU receivers.

FIGURE 7. LIU TRANSMIT CONNECTION DIAGRAM USING INTERNAL TERMINATION

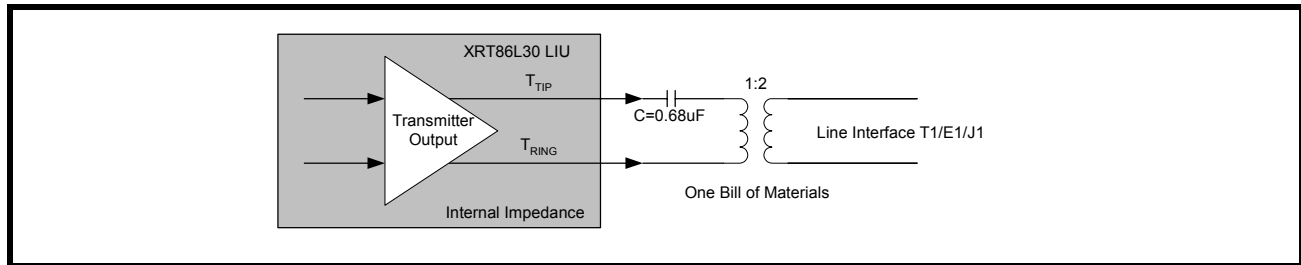
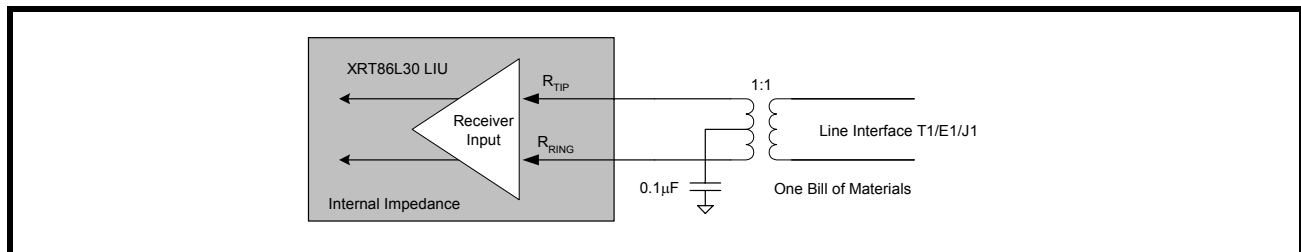

FIGURE 8. LIU RECEIVE CONNECTION DIAGRAM USING INTERNAL TERMINATION



4.2 R³ Technology (Relayless / Reconfigurable / Redundancy)

Redundancy is used to introduce reliability and protection into network card design. The redundant card in many cases is an exact replicate of the primary card, such that when a failure occurs the network processor can automatically switch to the backup card. EXAR's R³ technology has re-defined DS-1/E1/J1 physical interface design for 1:1 and 1+1 redundancy applications. Without relays and one Bill of Materials, EXAR offers multi-port, integrated Framer/LIU solutions to assist high density aggregate applications and framing requirements with reliability. The following section can be used as a reference for implementing R³ Technology with EXAR's world leading Framer/LIU combo.

4.2.1 Line Card Redundancy

Telecommunication system design requires signal integrity and reliability. When a T1/E1 primary line card has a failure, it must be swapped with a backup line card while maintaining connectivity to a backplane without losing data. System designers can achieve this by implementing common redundancy schemes with the XRT86L30 Framer/LIU. EXAR offers features that are tailored to redundancy applications while reducing the number of components and providing system designers with solid reference designs.

4.2.2 Typical Redundancy Schemes

- 1:1 One backup card for every primary card (Facility Protection)
- 1+1 One backup card for every primary card (Line Protection)
- N+1 One backup card for N primary cards

4.2.3 1:1 and 1+1 Redundancy Without Relays

The 1:1 facility protection and 1+1 line protection have one backup card for every primary card. When using 1:1 or 1+1 redundancy, the backup card has its transmitters tri-stated and its receivers in high impedance. This eliminates the need for external relays and provides one bill of materials for all interface modes of operation. For 1+1 line protection, the receiver inputs on the backup card have the ability to monitor the line for bit errors while in high impedance. The transmit and receive sections of the physical interface are described separately.

4.2.4 Transmit Interface with 1:1 and 1+1 Redundancy

The transmitters on the backup card should be tri-stated. Select the appropriate impedance for the desired mode of operation, T1/E1/J1. A 0.68uF capacitor is used in series with TTIP for blocking DC bias. See **Figure 9** for a simplified block diagram of the transmit section for a 1:1 and 1+1 redundancy.

FIGURE 9. SIMPLIFIED BLOCK DIAGRAM OF THE TRANSMIT INTERFACE FOR 1:1 AND 1+1 REDUNDANCY

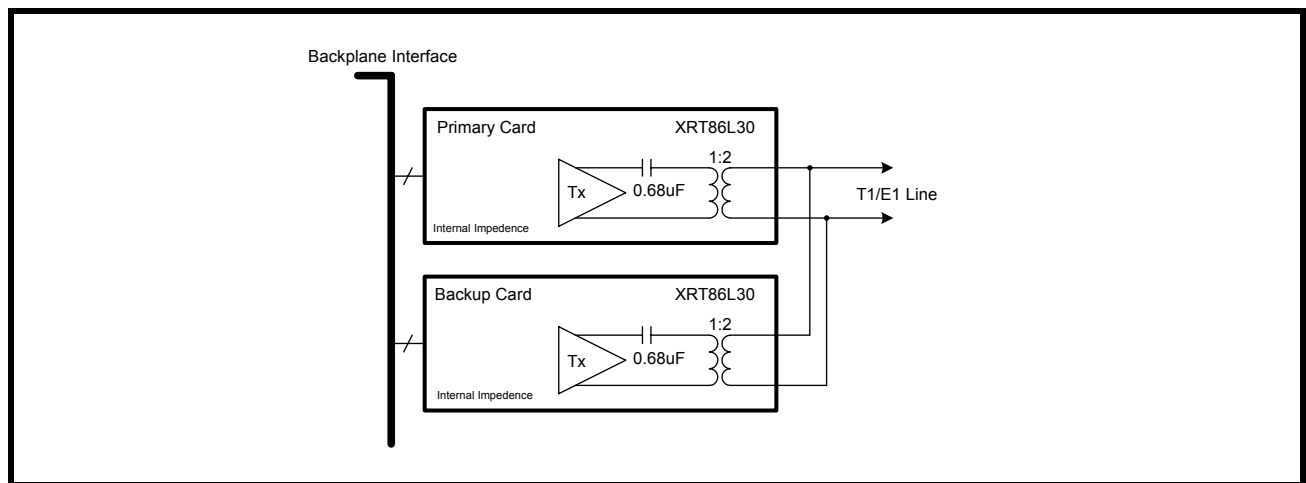

4.2.5 Receive Interface with 1:1 and 1+1 Redundancy

The receivers on the backup card should be programmed for "High" impedance. Since there is no external resistor in the circuit, the receivers on the backup card will not load down the line interface. This key design feature eliminates the need for relays and provides one bill of materials for all interface modes of operation. Select the impedance for the desired mode of operation, T1/E1/J1. To swap the primary card, set the backup card to internal impedance, then the primary card to "High" impedance. See **Figure 10**. for a simplified block diagram of the receive section for a 1:1 redundancy scheme.

FIGURE 10. SIMPLIFIED BLOCK DIAGRAM OF THE RECEIVE INTERFACE FOR 1:1 AND 1+1 REDUNDANCY

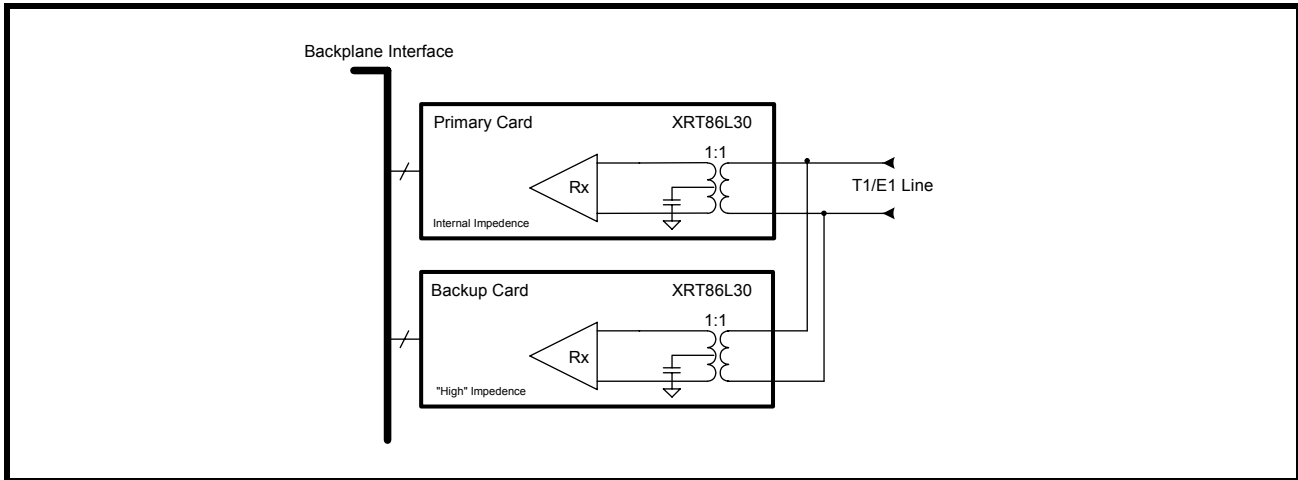

4.3 Power Failure Protection

For 1:1 or 1+1 line card redundancy in T1/E1 applications, power failure could cause a line card to change the characteristics of the line impedance, causing a degradation in system performance. The XRT86L30 was designed to ensure reliability during power failures. The LIU has patented high impedance circuits that allow the receiver inputs and the transmitter outputs to be in "High" impedance when the LIU experiences a power failure or when the LIU is powered off.

NOTE: For power failure protection, a transformer must be used to couple to the line interface. See the TAN-56 application note for more details.

4.4 Overvoltage and Overcurrent Protection

Physical layer devices such as LIUs that interface to telecommunications lines are exposed to overvoltage transients posed by environmental threats. An Overvoltage transient is a pulse of energy concentrated over a small period of time, usually under a few milliseconds. These pulses are random and exceed the operating conditions of CMOS transceiver ICs. Electronic equipment connecting to data lines are susceptible to many forms of overvoltage transients such as lightning, AC power faults and electrostatic discharge (ESD). There are three important standards when designing a telecommunications system to withstand overvoltage transients.

- UL1950 and FCC Part 68
- Telcordia (Bellcore) GR-1089
- ITU-T K.20, K.21 and K.41

NOTE: For a reference design and performance, see the TAN-54 application note for more details.

4.5 Non-Intrusive Monitoring

In non-intrusive monitoring applications, the transmitters are shut off by setting TxON "Low". The receivers must be actively receiving data without interfering with the line impedance. The XRT86L30's internal termination ensures that the line termination meets T1/E1 specifications for 75Ω, 100Ω or 120Ω while monitoring the data stream. System integrity is maintained by placing the non-intrusive receiver in "High" impedance, equivalent to that of a 1+1 redundancy application. A simplified block diagram of non-intrusive monitoring is shown in **Figure 11**.

FIGURE 11. SIMPLIFIED BLOCK DIAGRAM OF A NON-INTRUSIVE MONITORING APPLICATION

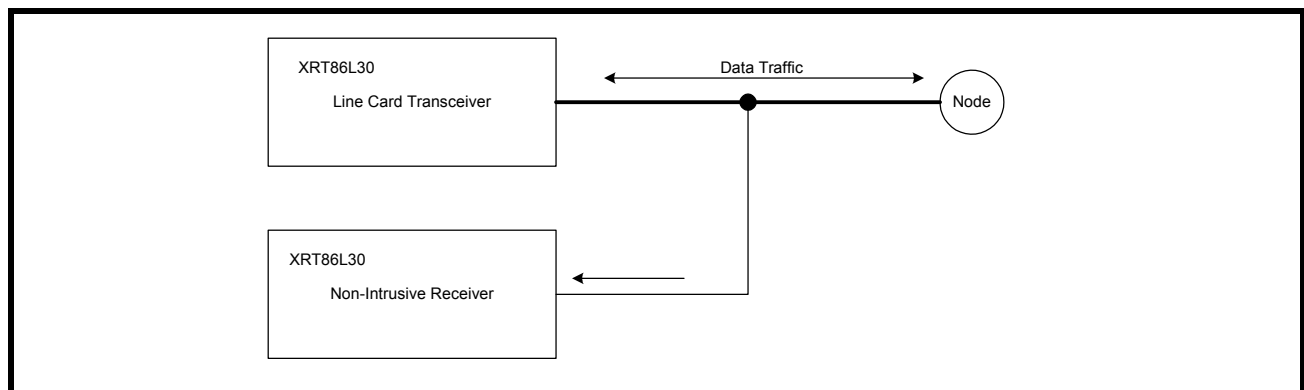

4.6 T1/E1 Serial PCM Interface

The most common mode is the standard serial PCM interface. Within this mode, only the serial data, serial clock, frame pulse and multi-frame pulse are required for both the transmit and receive paths. For the transmit path, only TxSER is a dedicated input to the device. All other signals to the transmit path in **Figure 12** can be programmed as either input or output. For the receive path, only RxSER and RxMSYNC are dedicated outputs from the device. All other signals in the receive path in **Figure 13** can be programmed as either input or output.

FIGURE 12. TRANSMIT T1/E1 SERIAL PCM INTERFACE

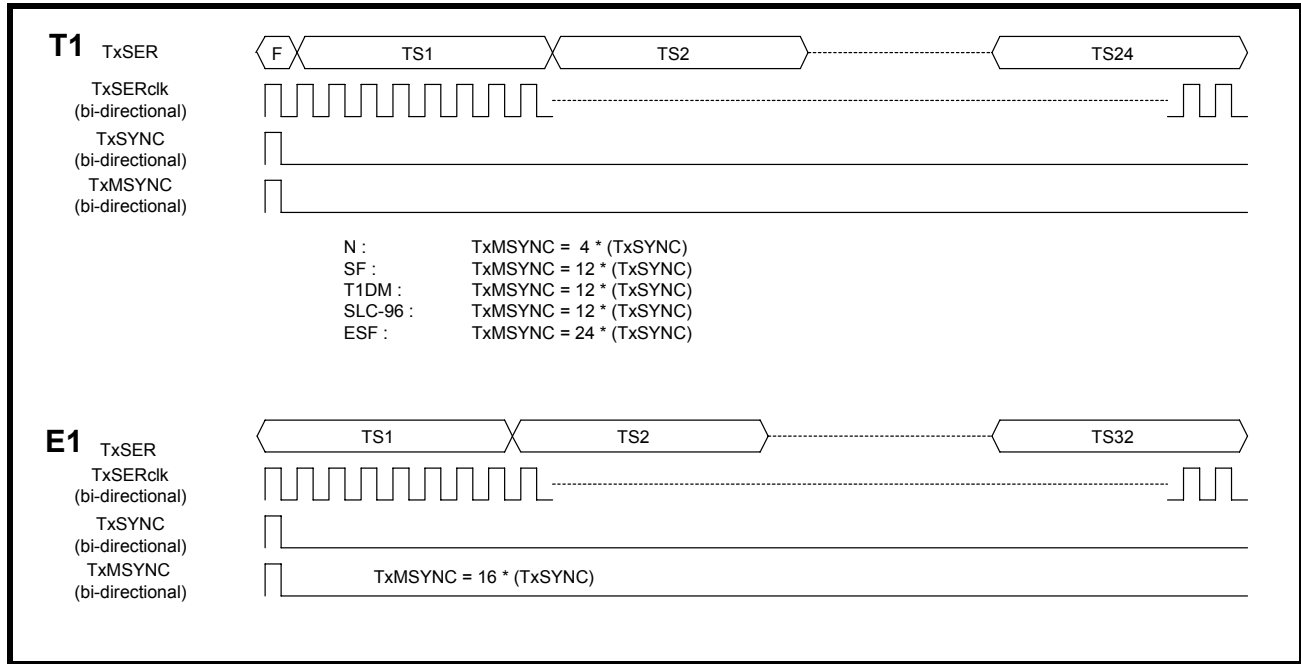
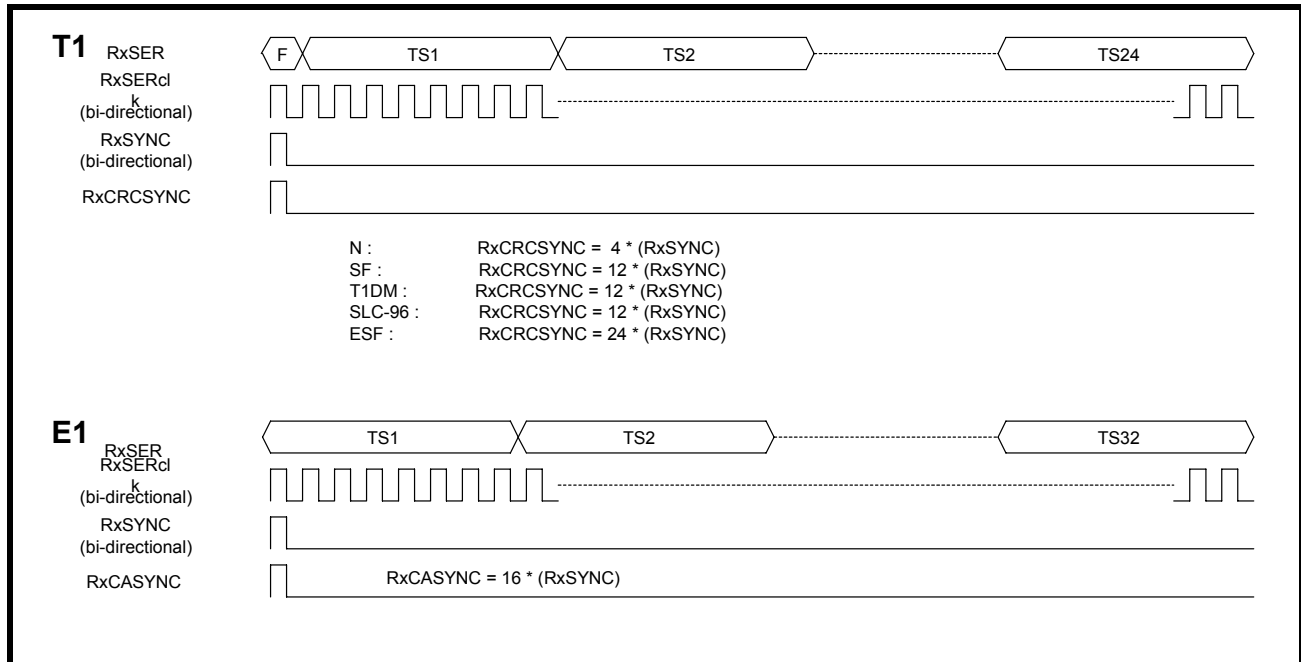

FIGURE 13. RECEIVE T1/E1 SERIAL PCM INTERFACE



4.7 T1/E1 Fractional Interface

The individual time slots can be enabled/disabled to carry fractional DS-0 data. The purpose of this interface is to enable one or more time slots in the PCM data (TxSER) to be replaced with the fractional DS-0 payload. If this mode is selected, the dedicated hardware pin TxCHN1/T1FR is used to input the fractional DS-0 data within the time slots that are enabled. The dedicated hardware pin RxCHN1/R1FR is used to output the fractional DS-0 data within the time slots that are enabled. **Figure 14** is a simplified diagram of the Fractional Interface.

FIGURE 14. T1 FRACTIONAL INTERFACE

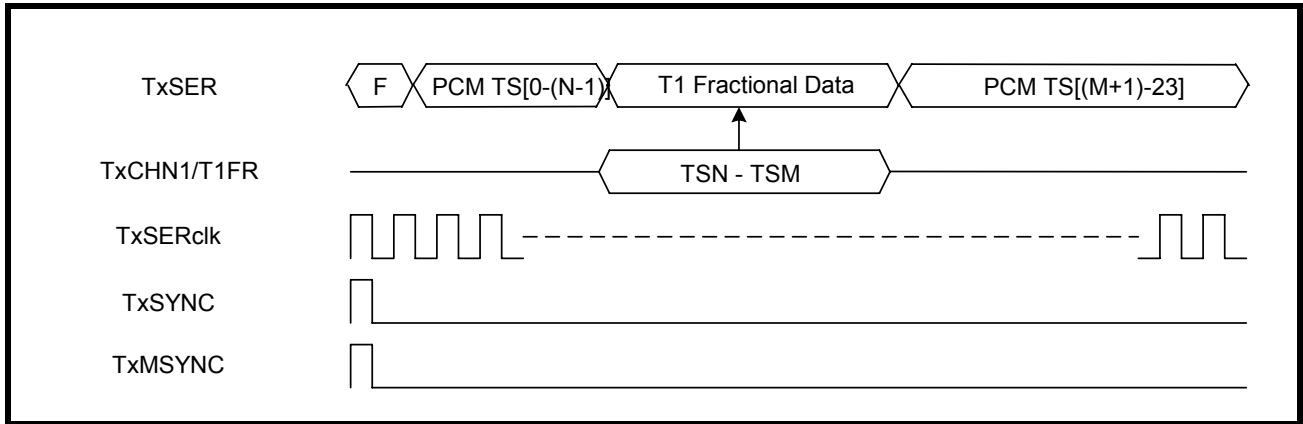

SINGLE T1/E1/J1 FRAMER/LIU COMBO

4.8 T1/E1 Time Slot Substitution and Control

The time slots within PCM data are reserved for carrying individual DS-0's. However, the framer block (transmit or receive paths) can substitute the payload with various code definitions. Each time slot can be independently programmed to carry normal PCM data or a variety of user codes. In E1 mode, the user can substitute the transmit time slots 0 and 16, although signaling and Frame Sync cannot be maintained. The following options for time slot substitution are available:

- Unchanged
- Invert all bits
- Invert even bits
- Invert odd bits
- Programmable User Code
- Busy 0xFF
- Vacant 0xD5
- Busy TS, Busy 00
- A-Law, μ -Law
- Invert the MSB bit
- Invert all bits except the MSB bit
- PRBS
- D/E Channel (or Fractional Input)

FIGURE 15. T1/E1 TIME SLOT SUBSTITUTION AND CONTROL

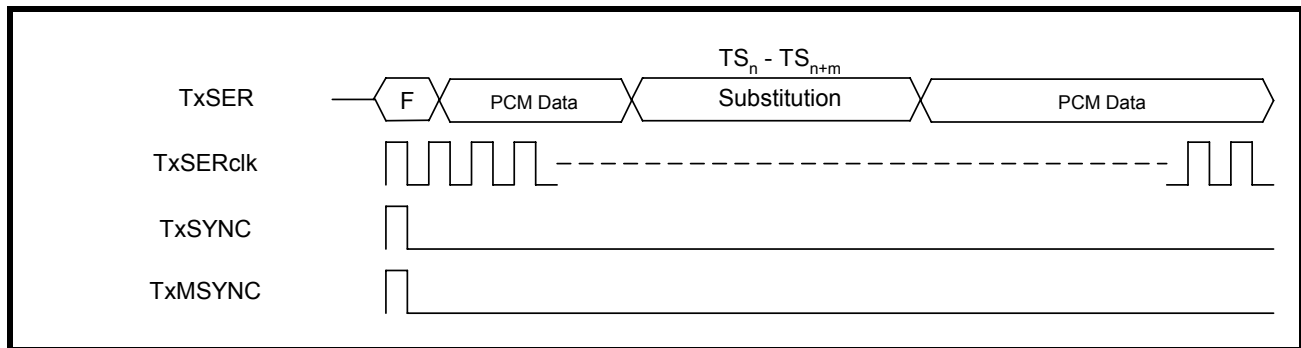

4.9 Robbed Bit Signaling/CAS Signaling

Signaling is used to convey status information relative to the individual DS-0's. If a particular DS-0 is On Hook, Off Hook, etc. this information is carried within the robbed bits in T1 (SF/ESF/SLC-96) or the sixteenth time slot in E1. On the transmit path, the Signaling information can be inserted through the PCM data, internal registers, or a dedicated external Signaling Bus by programming the appropriate registers. On the receive path, the signaling information is extracted (if enabled) to the internal registers and the external signaling bus in addition to being embedded within the PCM data. If the user wishes to substitute the ABCD values, the substitution only occurs in the PCM data. Once substituted, the internal registers and the external signaling bus will not be affected. **Figure 16** is a simplified block diagram showing the Signaling Interface. **Figure 17** is a timing diagram showing how to insert the ABCD values for each time slot in ESF / CAS. **Figure 18** is a timing diagram showing how to insert the AB values for SF / SLC-96 or 4-code signaling in ESF / CAS.

FIGURE 16. ROBBED BIT SIGNALING / CAS SIGNALING

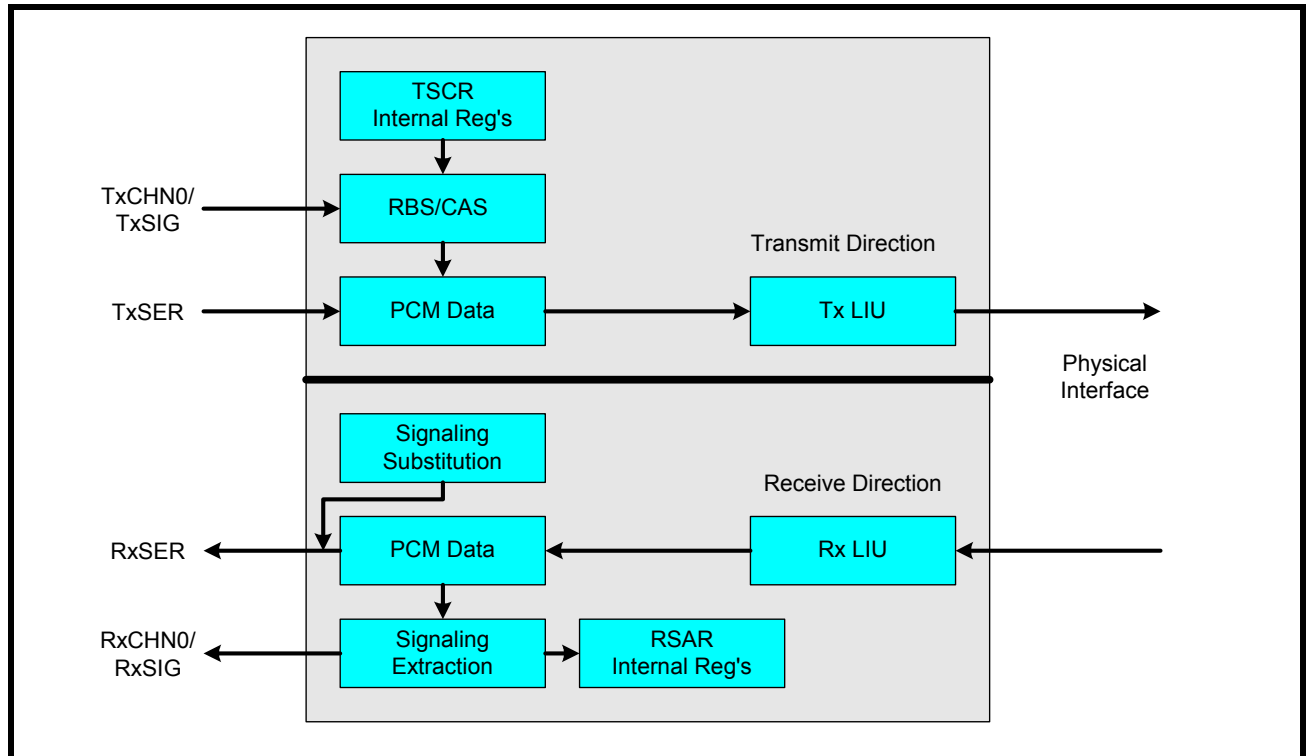

FIGURE 17. ESF / CAS EXTERNAL SIGNALING BUS

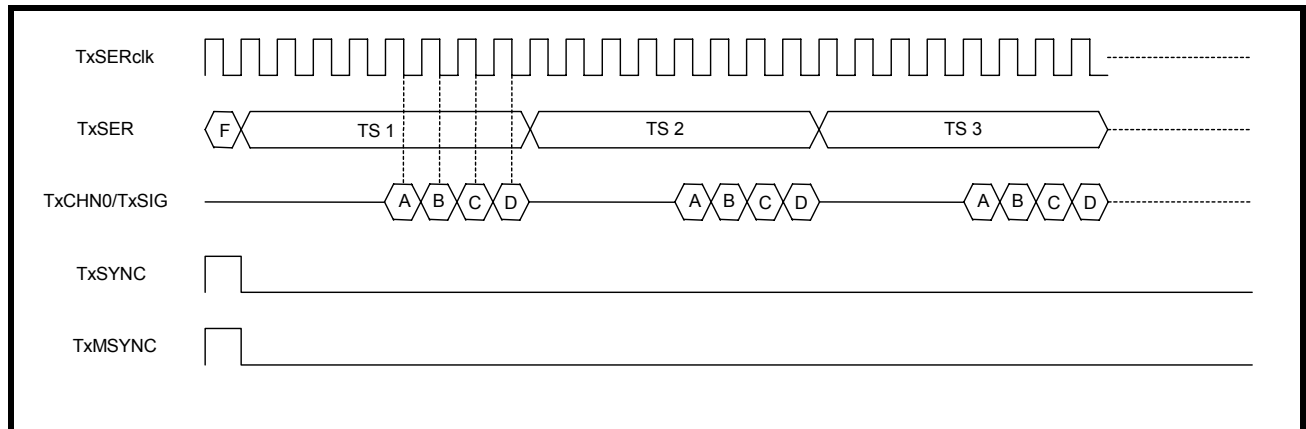
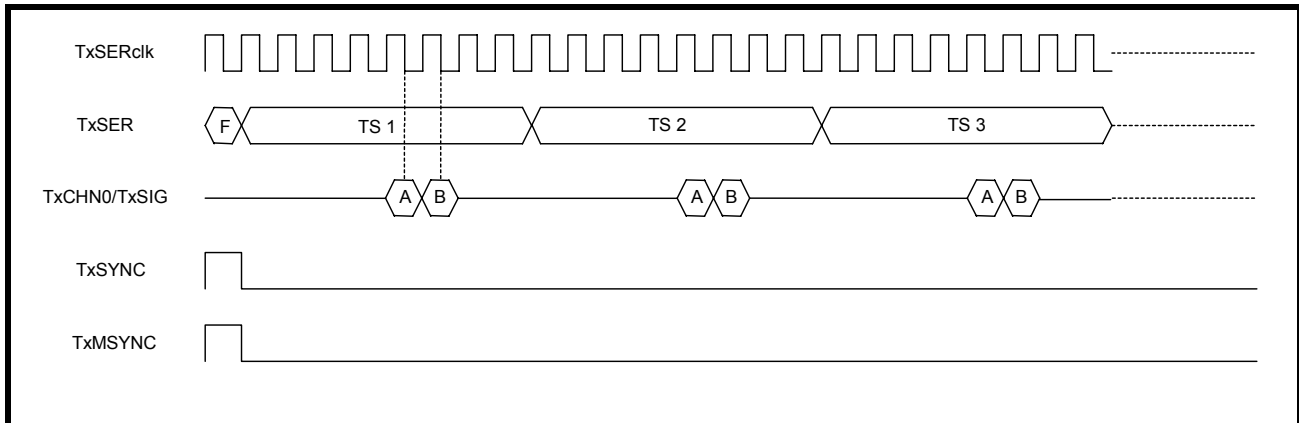

FIGURE 18. SF / SLC-96 OR 4-CODE SIGNALING IN ESF / CAS EXTERNAL SIGNALING BUS



4.10 Overhead Interface

The Overhead interface provides an option for inserting the datalink bits into the transmit PCM data or extracting the datalink bits from the receive PCM data. By default, the datalink information is processed to and from the PCM data directly. On the transmit path, the overhead clock is automatically provided as a clock reference to externally time the datalink bits. The user should provide data on the rising edge of the TxOHclk so that the framer can sample the datalink bits on the falling edge. On the receive path, the datalink bits are updated on the rising edge of the RxOHclk output pin. In T1 ESF mode, a datalink bit occurs every other frame. Therefore, the default overhead interface is operating at 4kbps. In E1 mode, the datalink bits are located in the first time slot of each Non-FAS frame. **Figure 19** is a simplified block diagram of the Overhead Interface. **Figure 20** is a simplified diagram for the T1 external overhead datalink bus. **Figure 21** is a simplified diagram for the E1 external overhead datalink bus.

FIGURE 19. T1/E1 OVERHEAD INTERFACE

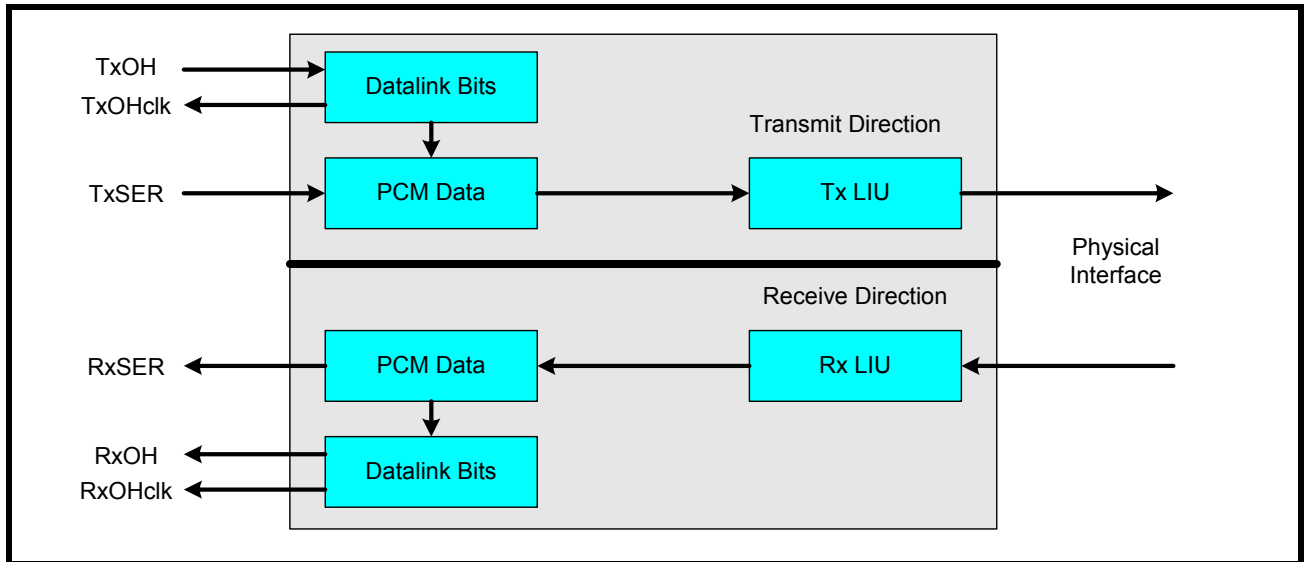

FIGURE 20. T1 EXTERNAL OVERHEAD DATALINK BUS

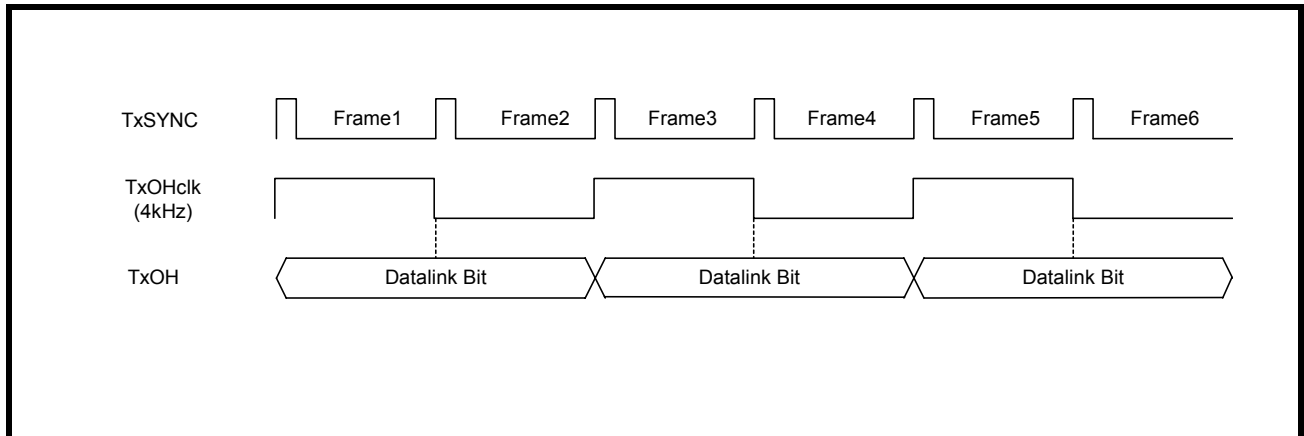
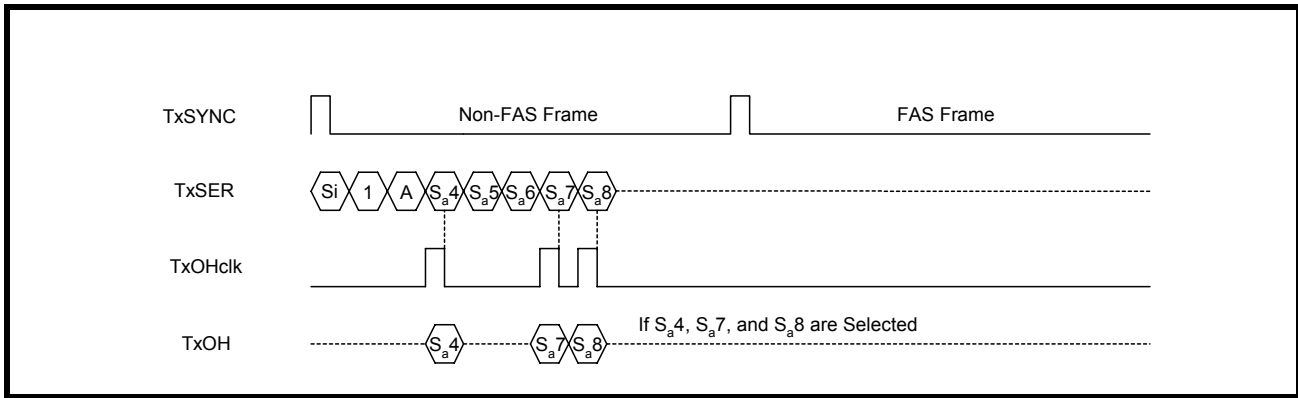

FIGURE 21. E1 OVERHEAD EXTERNAL DATALINK BUS



4.11 Framer Bypass Mode

The framer bypass mode allows the XRT86L30 to be used as a stand alone Line Interface Unit. In this mode, a few of the backplane interface signals multiplex into the digital Input/output signals to and from the LIU block. Figure 22 shows a simplified block diagram of the framer bypass mode.

FIGURE 22. SIMPLIFIED BLOCK DIAGRAM OF THE FRAMER BYPASS MODE

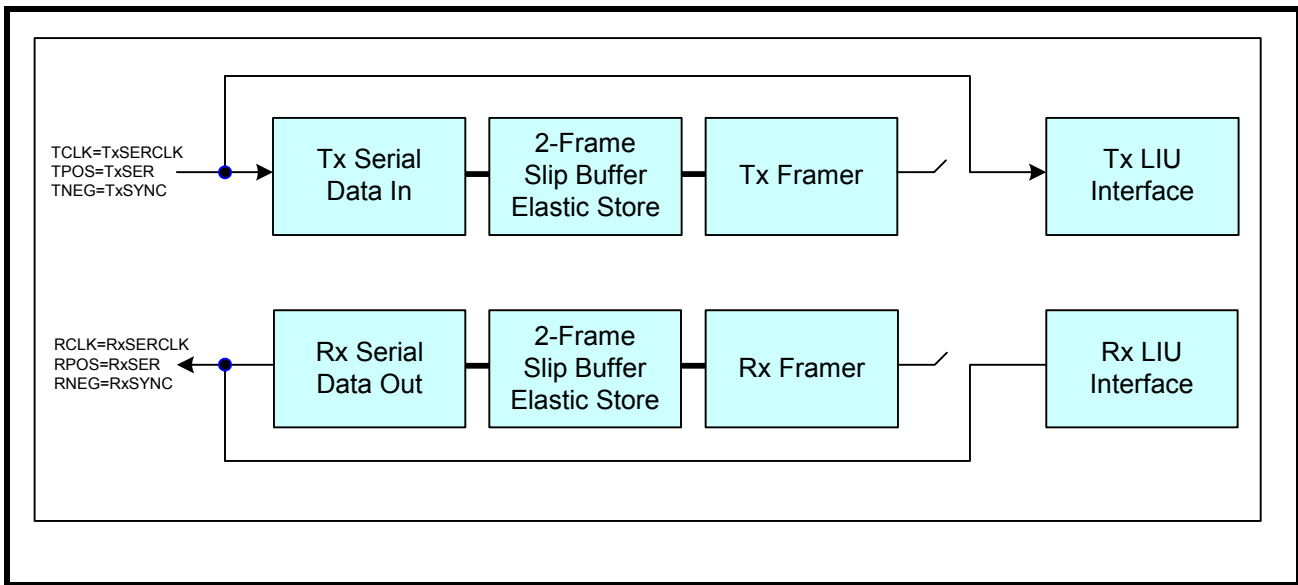

4.12 High-Speed Non-Multiplexed Interface

The speed of transferring data through a back plane interface in a non-multiplexed manner typically operates at 1.544Mbps, 2.048Mbps, 4.096Mbps, or 8.192Mbps. For 12.352Mbps and 16.384Mbps, see the High-Speed Multiplexed Section. The T1/E1 carrier signal out to or in from the line interface is always 1.544MHz and 2.048MHz respectively. However, the back plane interface may be synchronous to a “Higher” speed clock. For T1, as shown in **Figure 23**, is mapped into an E1 frame. Therefore, every fourth time slot contains non-valid data. For E1, as shown in **Figure 24**, is simply synchronized to the “Higher” 8.192MHz clock signal supplied to the TxMSYNC input pin.

FIGURE 23. T1 HIGH-SPEED NON-MULTIPLEXED INTERFACE

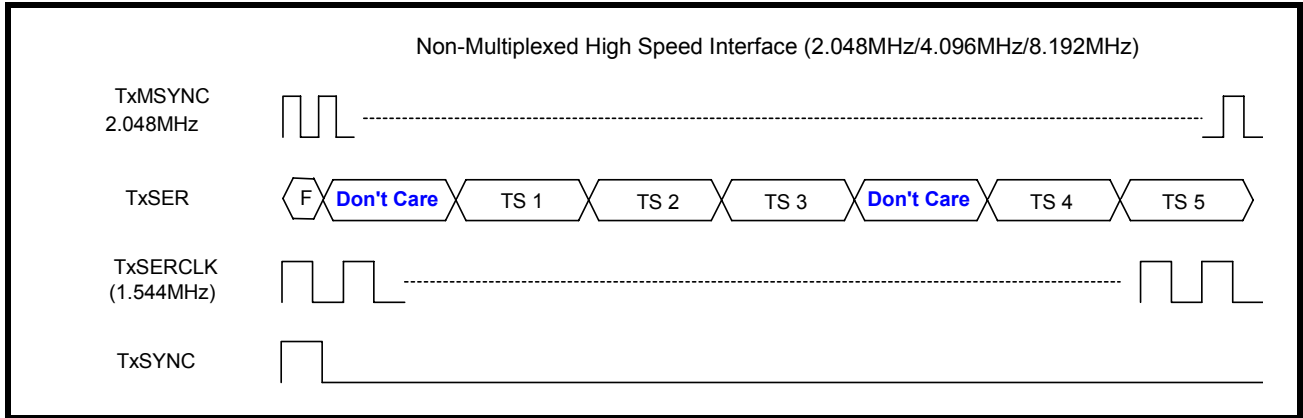
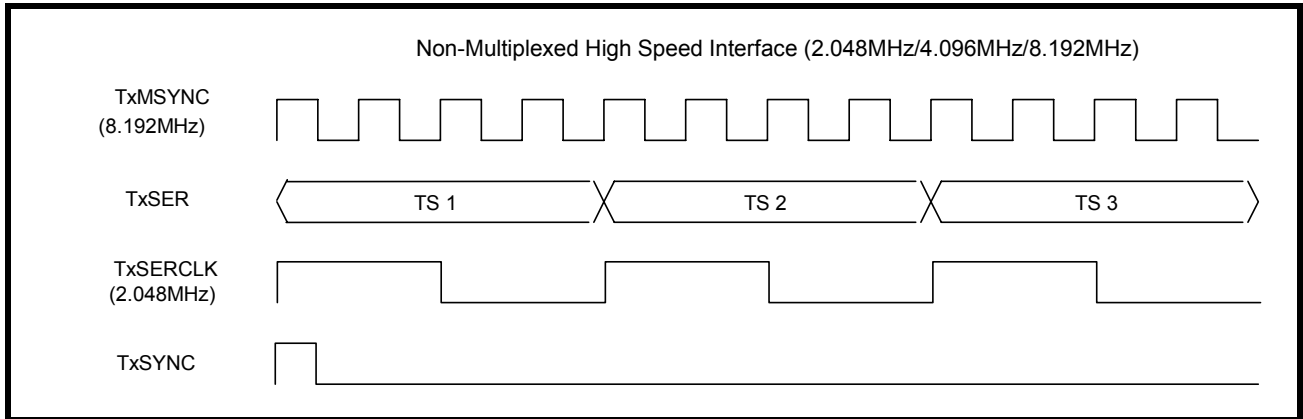

FIGURE 24. E1 HIGH-SPEED NON-MULTIPLEXED INTERFACE



4.13 High-Speed Multiplexed Interface

In addition to the non-multiplexed mode, the framer can interface through the backplane in a high-speed multiplexed application, either through a bit-muxed or byte-muxed (in H.MVIP or H.100) manner. In this mode, the chip is divided into two multiplexed blocks, four channels per block. For T1, the high speed multiplexed modes are 12.352Mbps (bit-muxed, TxSYNC is “High” during the F-bit), 16.384Mbps (bit-muxed, TxSYNC is “High” during the F-bit), 16.384Mbps (H.MVIP: byte-muxed, TxSYNC is “High” during the last 2-bits of the previous frame and the first 2-bits of the current frame), or 16.384Mbps (H.100: byte-muxed, TxSYNC is “High” during the last bit of the previous frame and the first bit in the current frame). For E1 mode, the only mode that is not supported is the 12.352Mbps. The only other difference is that the F-bit (for T1 mode) becomes the first bit of the E1 frame. **Figure 25** is a simplified block diagram of transmit bit-muxed application. **Figure 26** is a simplified block diagram of receive bit-muxed application. Although the data is only applied to channel 4 or channel 0, the TxSERCLK is necessary for all channels so that the transmit line rate is always equal to the T1/E1 carrier rate.

FIGURE 25. TRANSMIT HIGH-SPEED BIT MULTIPLEXED BLOCK DIAGRAM

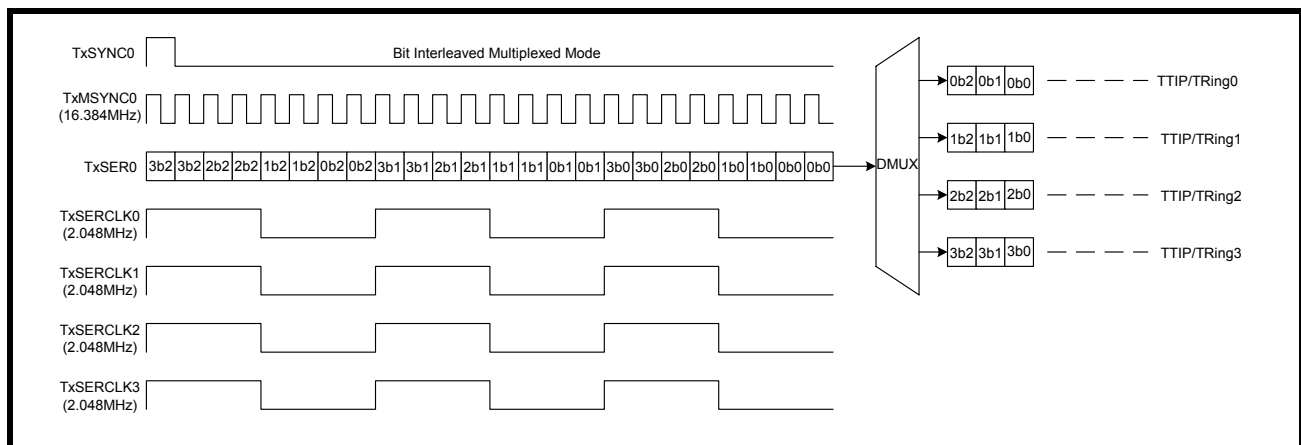
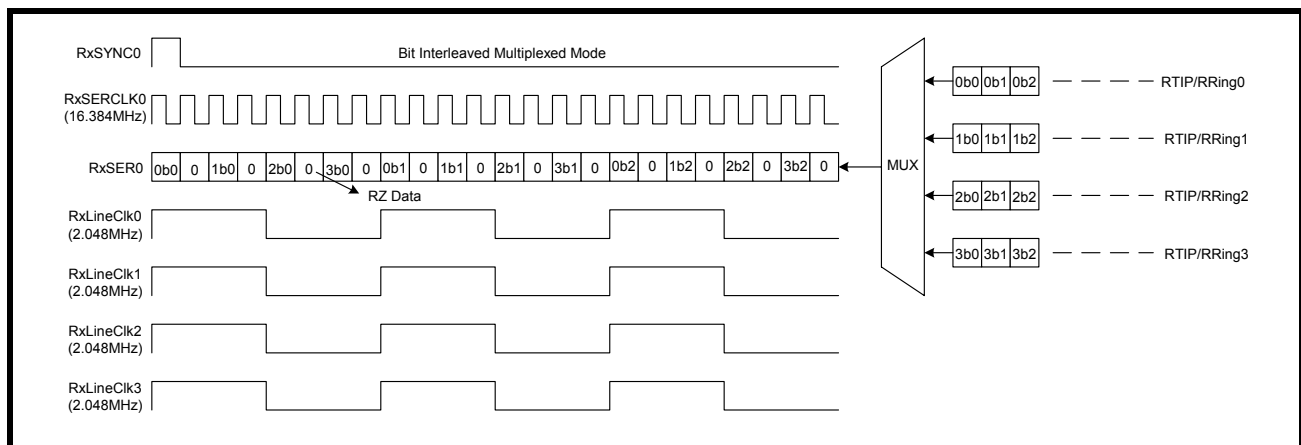

FIGURE 26. RECEIVE HIGH-SPEED BIT MULTIPLEXED BLOCK DIAGRAM



5.0 LOOPBACK MODES OF OPERATION

5.1 LIU Physical Interface Loopback Diagnostics

The XRT86L30 supports several loopback modes for diagnostic testing. The following section describes the local analog loopback, remote loopback, digital loopback, and dual loopback modes. The LIU physical interface loopback modes are independent from the Framer loopback modes. Therefore, it is possible to configure multiple loopback modes creating tremendous flexibility within the looped diagnostic features.

5.1.1 Local Analog Loopback

With local analog loopback activated, the transmit output data at TTIP/TRING is internally looped back to the analog inputs at RTIP/RRING. External inputs at RTIP/RRING are ignored while valid transmit output data continues to be sent to the line. A simplified block diagram of local analog loopback is shown in **Figure 27**.

FIGURE 27. SIMPLIFIED BLOCK DIAGRAM OF LOCAL ANALOG LOOPBACK

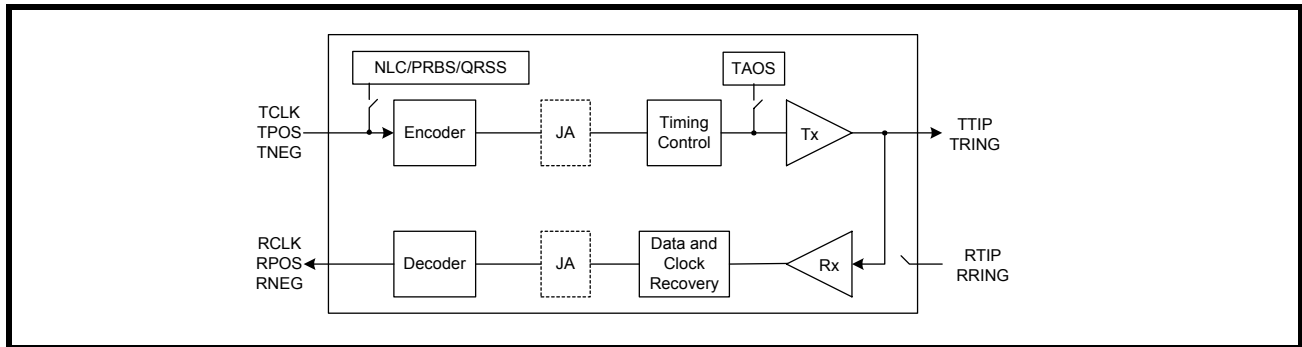

NOTE: The transmit diagnostic features such as TAOS, NLC generation, and QRSS take priority over the transmit input data at TCLK/TPOS/TNEG.

5.1.2 Remote Loopback

With remote loopback activated, the receive input data at RTIP/RRING is internally looped back to the transmit output data at TTIP/TRING. The remote loopback includes the Receive JA (if enabled). The transmit input data at TCLK/TPOS/TNEG are ignored while valid receive output data continues to be sent to the system. A simplified block diagram of remote loopback is shown in **Figure 28**.

FIGURE 28. SIMPLIFIED BLOCK DIAGRAM OF REMOTE LOOPBACK

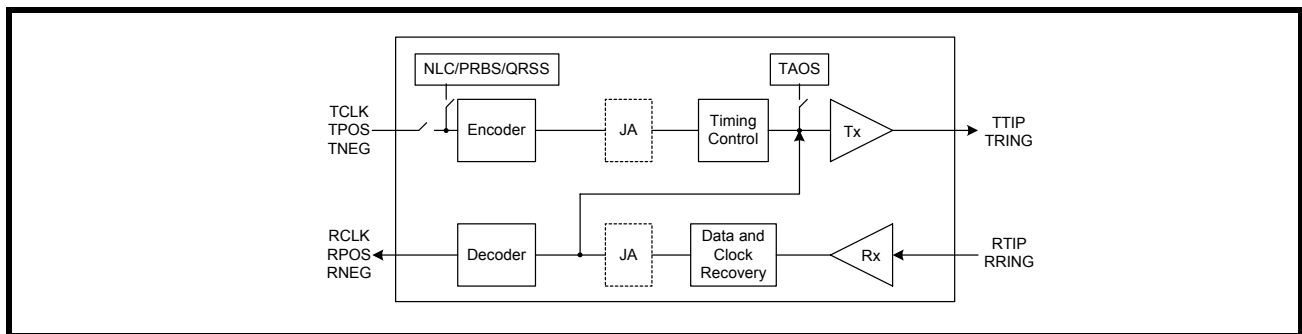

5.1.3 Digital Loopback

With digital loopback activated, the transmit input data at TCLK/TPOS/TNEG is looped back to the receive output data at RCLK/RPOS/RNEG. The digital loopback mode includes the Transmit JA (if enabled). The receive input data at RTIP/RRING is ignored while valid transmit output data continues to be sent to the line. A simplified block diagram of digital loopback is shown in **Figure 29**.

FIGURE 29. SIMPLIFIED BLOCK DIAGRAM OF DIGITAL LOOPBACK

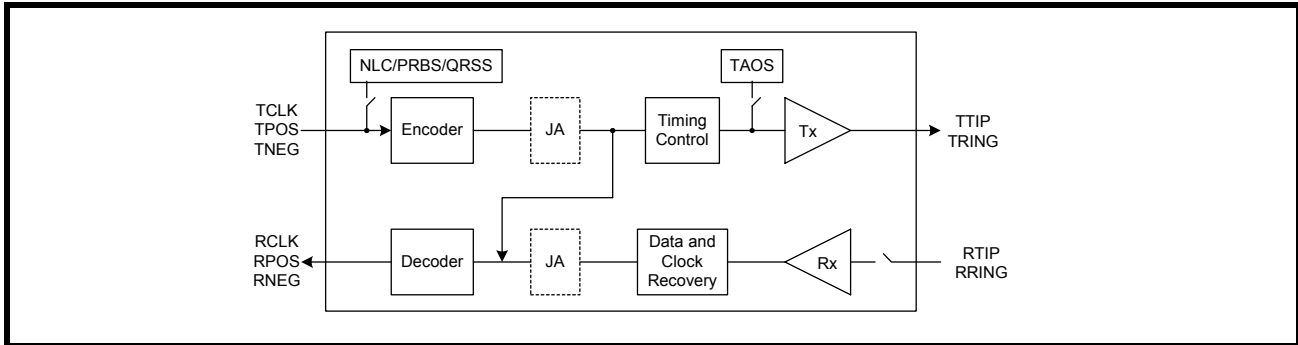

5.1.4 Dual Loopback

With dual loopback activated, the remote loopback is combined with the digital loopback. A simplified block diagram of dual loopback is shown in **Figure 30**.

FIGURE 30. SIMPLIFIED BLOCK DIAGRAM OF DUAL LOOPBACK

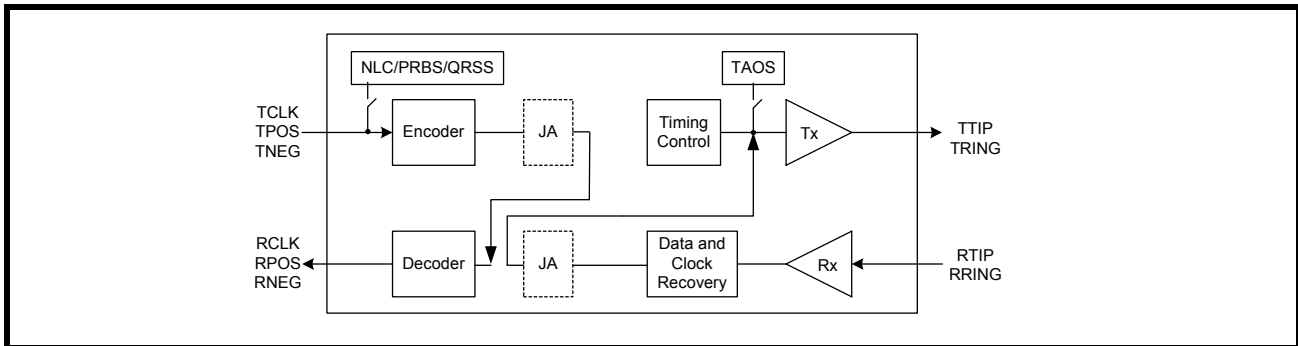

5.1.5 Framer Remote Line Loopback

The Framer Remote Line Loopback is almost identical to the LIU physical interface Remote Loopback. The digital data enters the framer interface, however does not enter the framing blocks. The main difference between the Remote loopback and the Framer Remote Line loopback is that the receive digital data from the LIU is allowed to pass through the LIU Decoder/Encoder circuitry before returning to the line interface. A simplified block diagram of framer remote line loopback is shown in **Figure 31**.

FIGURE 31. SIMPLIFIED BLOCK DIAGRAM OF THE FRAMER REMOTE LINE LOOPBACK

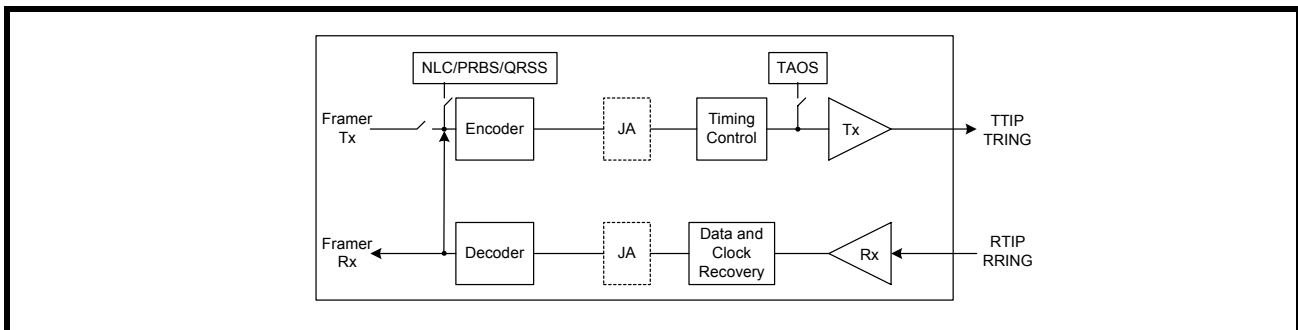

5.1.6 Framer Payload Loopback

With framer payload loopback activated, the raw data within the receive time slots are looped back to the transmit framer block where the data is re-framed according to the transmit timing. A simplified block diagram of framer payload loopback is shown in **Figure 32**.

FIGURE 32. SIMPLIFIED BLOCK DIAGRAM OF THE FRAMER LOCAL LOOPBACK

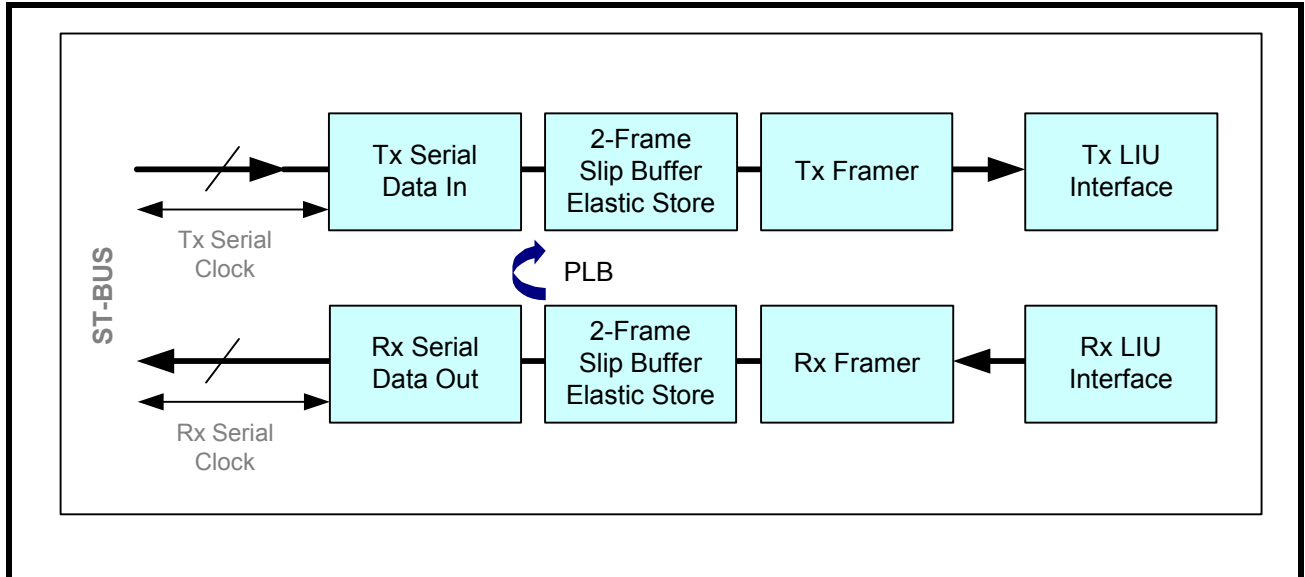

5.1.7 Framer Local Loopback

With framer local loopback activated, the transmit PCM input data is looped back to the receive PCM output data. The receive input data at RTIP/RRING is ignored while an All Ones Signal is transmitted out to the line interface. A simplified block diagram of framer remote line loopback is shown in **Figure 33**.

FIGURE 33. SIMPLIFIED BLOCK DIAGRAM OF THE FRAMER LOCAL LOOPBACK

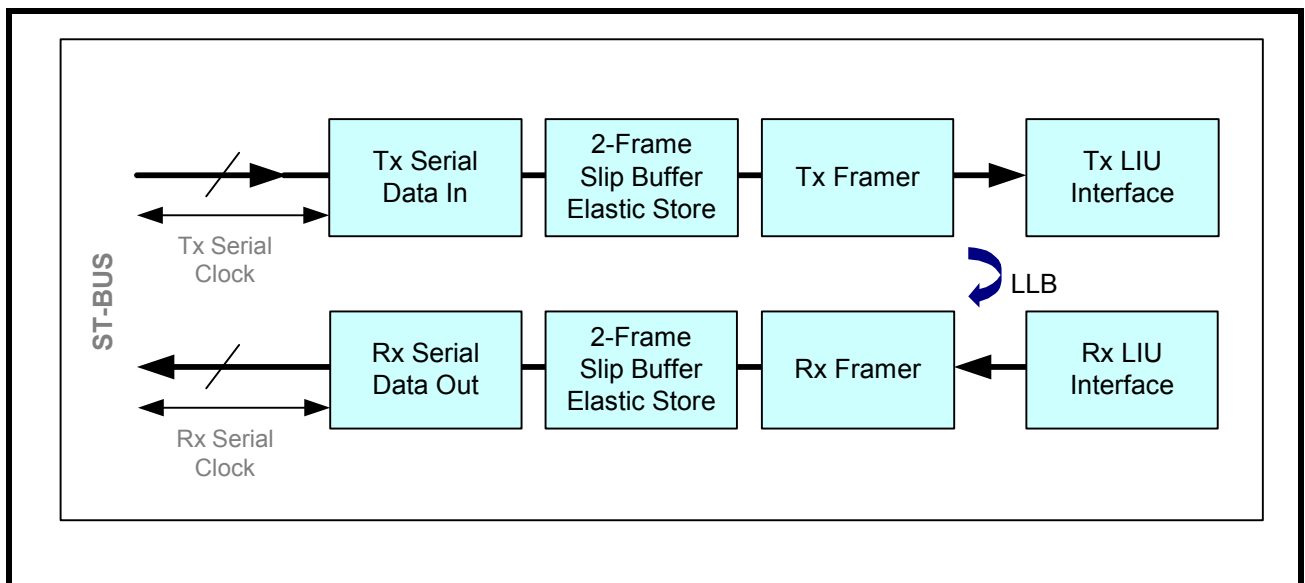

6.0 HDLC CONTROLLERS AND LAPD MESSAGES

The purpose of the HDLC controllers is to allow messages to be stored for transport in the outbound transmit framer block or extracted from the receive framer block through the LAPD interface. The Framer has 3 independent HDLC controllers. Each HDLC controller has two 96-Byte buffers for Transmit and two 96-Byte buffers for Receive. The buffers are used to insert messages into the out going data stream for Transmit or to extract messages from the incoming data stream from the Receive path. Total, there are twelve 96-Byte buffers per channel. This allows multiple HDLC messages to be transported to and from EXAR's framing device.

FIGURE 34. HDLC CONTROLLERS

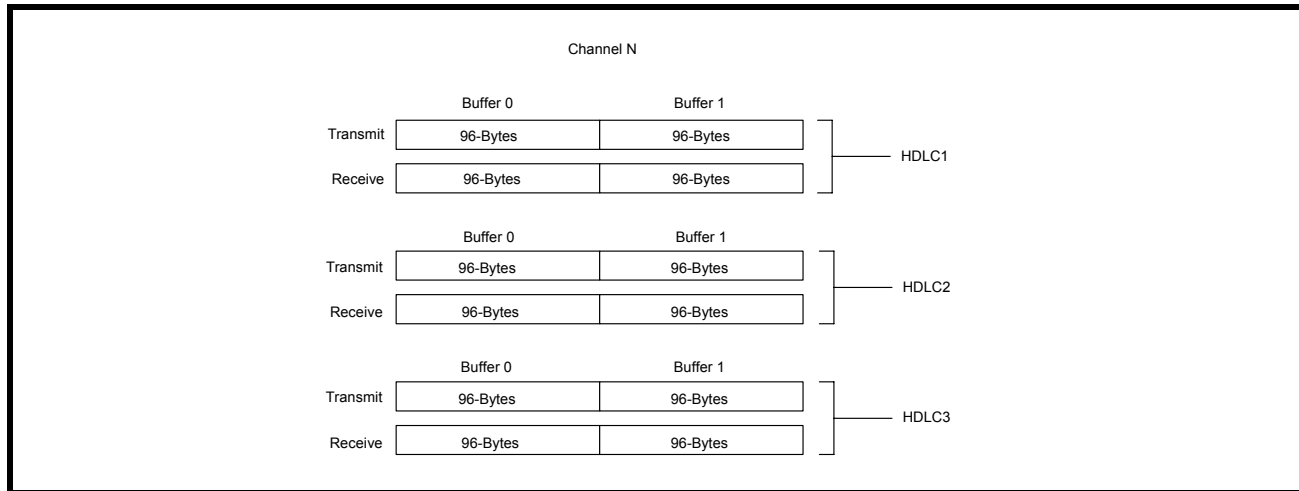

6.1 Programming Sequence for Sending Less Than 96-Byte Messages

Once the data link source and the type of message has been chosen, the following programming sequence can be followed to send (in this example) a 15-byte LAPD message.

NOTE: To send more than 96-Bytes, the programming sequence is slightly modified, which is described in the next section.

1. Read the Transmit Data Link Byte Count Register to determine which buffer is available.
2. Enable TxSOT in the Data Link Interrupt Enable Register.
3. Write 0x0F into the transmit byte count register (assuming buffer 0 was available).
4. Write the 15-byte message contents into register 0x0600 (automatically incremented).
5. Enable the LAPD transmission by writing to register 0x0113.
6. Once TxEOT occurs, the message has been transmitted.

6.2 Programming Sequence for Sending Large Messages

1. Read the Transmit Data Link Byte Count Register to determine which buffer is available.
2. Enable TxSOT in the Data Link Interrupt Enable Register.
3. Write 0x60 into the transmit byte count register (assuming buffer 0 was available).
4. Write the first 96-bytes into register 0x0600 (buffer 0, automatically incremented).
5. Enable the LAPD transmission by writing to register 0x0113.
6. Wait for the TxSOT before writing the next 96-bytes.
7. Re-initiate the TxSOT interrupt enable.
8. Write 0xE0 into the transmit byte count register (buffer 1).
9. Write the next 96-bytes into 0x0700 (buffer 1, automatically incremented).
10. Enable the LAPD transmission by writing to register 0x0113.
11. Wait for the TxSOT before writing the next 96-bytes.
12. Continue until the entire message is sent.

6.3 Programming Sequence for Receiving LAPD Messages

The XRT86L30 can extract data link information from incoming DS1 frames from either the datalink bits themselves or the D/E time slots within the PCM input data. To extract a LAPD message, the following programming sequence can be used as a reference.

1. Enable RxEOT in the Data Link Interrupt Enable Register.
2. Wait for the RxEOT interrupt to occur.
3. Once RxEOT occurs, read the Receive Data Link Byte Count Register to determine which buffer the data is extracted to and how many bytes are contained within the message.
4. Read the exact amount of bytes from the proper buffer. If buffer 0, read 0x0600. If buffer 1, read 0x0700. These two registers are automatically incremented.

6.4 SS7 (Signaling System Number 7) for ESF in DS1 Only

To support SS7 specifications while receiving LAPD messages, EXAR's Framer will generate an interrupt (if SS7 is enabled) once the HDLC controllers have received more than 276 bytes within two flag sequences (0x7E) of a LAPD message. Each HDLC controller supports SS7. For example: To enable SS7 for all HDLC controllers, registers 0x0B11 (LAPD1), 0x0B19 (LAPD2), 0x0B29 (LAPD3) must be set to 0x01.

6.5 DS1/E1 Datalink Transmission Using the HDLC Controllers

The transmit framer block can insert data link information to outbound DS1/E1 frames. The data link information can be inserted from the following sources.

- Transmit Overhead Input Interface (TxOH)
- Transmit HDLC1 Controller
- Transmit Serial Input Interface (TxSER)

NOTE: HDLC1 is the dedicated controller for transmission of LAPD messages through the datalink bits. If the datalink bits are not used for LAPD messages, then HDLC1 can be used through the D/E time slots as with HDLC2 and HDLC3.

The Transmit Data Link Source Select bits within the Transmit Data Link Select Register (TSDLSR) determine the source for the data link bits in ESF, SLC@96, or T1DM for DS1 and CRC multi frame for E1. Each Transmit HDLC Controller contains four major functional modules.

- Bit-Oriented Signaling Processor
- LAPD Controller
- SLC@96 Data Link Controller
- Automatic Performance Report (APR) Generation

6.6 Transmit BOS (Bit Oriented Signaling) Processor

The Transmit BOS Processor handles transmission of BOS messages through the data link channel. The processor can be set for a specific amount of repetitions a certain BOS message will be transmitted, or it may be placed in an infinite loop. The processor can also insert a BOS IDLE flag sequence and/or an ABORT sequence to be transmitted on the data link channel.

6.6.1 Description of BOS

Bit-Oriented Signaling messages are a 16-bit pattern of which a 6-bit message is embedded as shown in the following table.

BOS MESSAGE FORMAT															
0	D5	D4	D3	D2	D1	D0	0	1	1	1	1	1	1	1	1

Where D5 is the MSB and D0 is the LSB. The rightmost "1" is transmitted first. BOS is classified into the following two groups.

- Priority Codeword Message
- Command and Response Information

6.6.2 Priority Codeword Message

A Priority Codeword Message is preemptive and has the highest priority among all data link information. A Priority Codeword indicates a condition that is affecting the quality of service and thus shall be transmitted until the condition no longer exists. The duration of transmission should not be less than one second. A priority codeword may be interrupted by software for 100 milliseconds to send maintenance commands with a minimum interval of one second between interruptions. Yellow alarm (00000000 11111111) is the only priority message defined in industry standards.

6.6.3 Command and Response Information

Command and Response Information is transmitted to perform various functions. The BOS Processor can send a command and response by transmitting a minimum of 10 repetitions of the appropriate codeword pattern. A Command and response data transmission initiates action at the remote end, while the remote end will respond by sending Bit-Oriented response message to acknowledge the received commands. The activation and deactivation of line remote loop-back and local payload loop-back functions are of this type.

6.7 Transmit MOS (Message Oriented Signaling) Processor

The Transmit LAPD controller implements the Message-Oriented protocol based on ITU Recommendation Q.921 Link Access Procedures on the D-channel. It provides the following functions.

- Zero stuffing
- T1/E1 transmitter interface
- Transmit message buffer access
- Frame check sequence generation
- IDLE flag insertion
- ABORT sequence generation

Two 96-byte buffers in shared memory are allocated for each LAPD to reduce the frequency of microprocessor interrupts and alleviate the response time requirement for a microprocessor to handle each interrupt. There are no restrictions on the length of the message. However the 96-byte buffer is deep enough to hold one entire LAPD path or test signal identification message.

6.7.1 Discussion of MOS

Message-Oriented signals sent by the transmit LAPD Controller are messages conforming to ITU Recommendation Q.921 LAPD protocol. There are two types of Message-Oriented signals. One is a periodic performance report generated by the source or sink T1/E1 terminals as defined by ANSI T1.403. The other is a path or test signal identification message that may be optionally generated by a terminal or intermediate equipment on a T1/E1 circuit. The message structures of the performance report and path or test signal identification message are shown in **Figure 35** for format A and format B respectively.

FIGURE 35. LAPD FRAME STRUCTURE

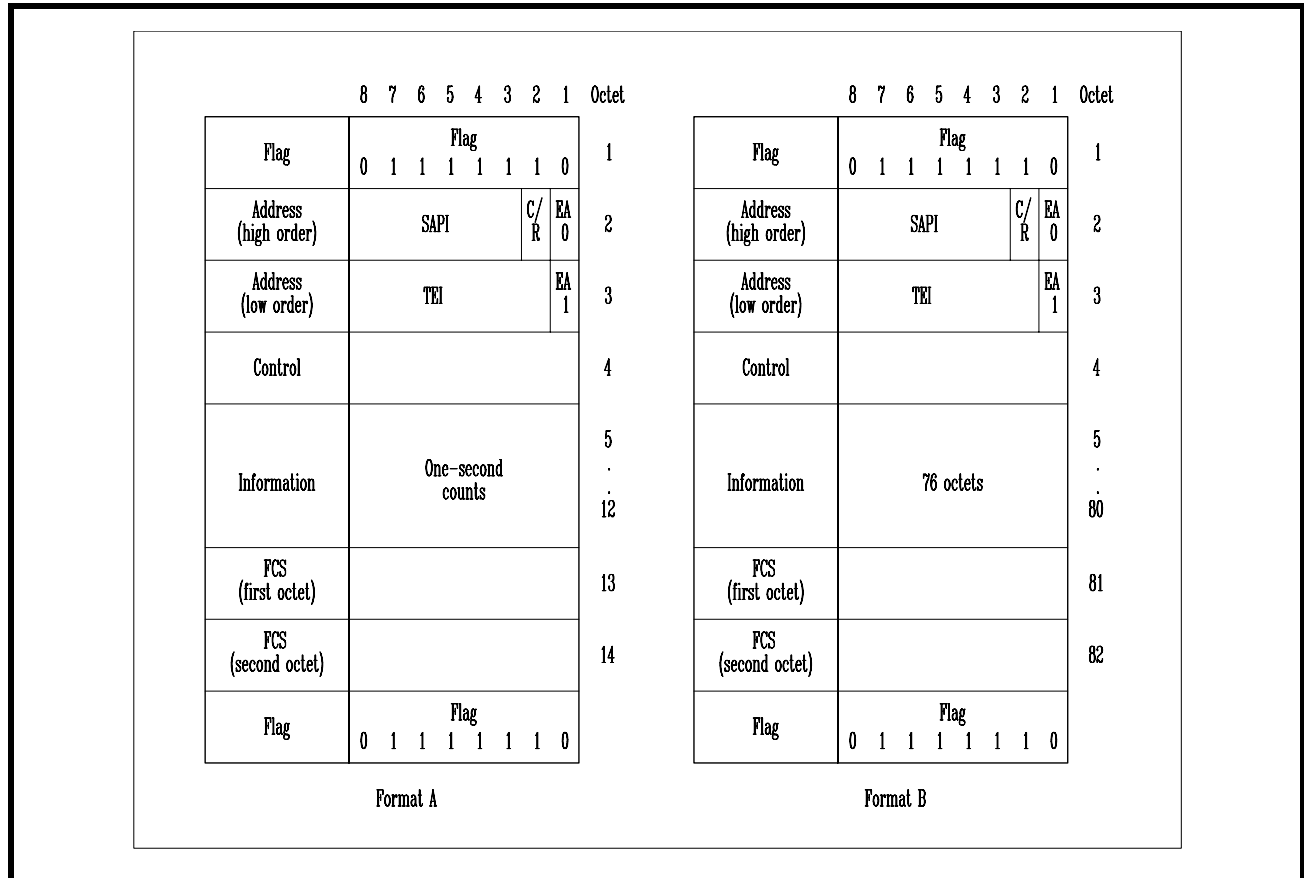

6.7.2 Periodic Performance Report

The ANSI T1.403 standard requires that the status of the transmission quality be reported in one-second intervals. The one-second timing may be derived from the DS1 signal or from a separate equally accurate (± 32 ppm) source. The phase of the one-second periods does not depend on the time of occurrence of any error event. A total of four seconds of information is transmitted so that recovery operations may be initiated in case an error corrupts a message. Counts of events shall be accumulated in each contiguous one-second interval. At the end of each one-second interval, a modulo-4 counter shall be incremented, and the appropriate performance bits shall be set in bytes 5 and 6 in Format A. These octets and the octets that carry the performance bits of the preceding three one-second intervals form the periodic performance report.

The periodic performance report is made up of 14 bytes of data. Bytes 1 to 4, 13, and 14 are the message header and bytes 5 to 12 contain data regarding the four most-recent one-second intervals. The periodic performance report message uses the SAPI/TEI value of 0x14.

6.7.3 Transmission-Error Event

Occurrences of transmission-error events indicate the quality of transmission. The occurrences that shall be detected and reported are:

- **CRC Error Event:** A CRC-6 error event is the occurrence of a received CRC code that is not identical to the corresponding locally calculated code.
- **Severely Errored Framing Event:** A severely-errored-framing event is the occurrence of two or more framing-bit-pattern errors within a 3-ms period. Contiguous 3-ms intervals shall be examined. The 3-ms period may coincide with the ESF. The severely-errored-framing event, while similar in form to criteria for declaring a terminal has lost framing, is only designed as a performance indicator; existing terminal out-of-frame criteria will continue to serve as the basis for terminal alarms.
- **Frame-Synchronization-Bit Error Event:** A frame-synchronization-bit-error event is the occurrence of a received framing-bit-pattern not meeting the severely-errored-framing event criteria.
- **Line-Code Violation event:** A line-code violation event is a bipolar violation of the incoming data. A line-code violation event for an B8ZS-coded signal is the occurrence of a received excessive zeros (EXZ) or a bipolar violation that is not part of a zero-substitution code.
- **Controlled Slip Event:** A controlled-slip event is a replication, or deletion, of a T1 frame by the receiving terminal. A controlled slip may occur when there is a difference between the timing of a synchronous receiving terminal and the received signal.

6.7.4 Path and Test Signal Identification Message

The path identification message is used to identify the path between the source terminal and the sink terminal. The test signal identification message is used by test signal generating equipment. Both identification messages are made up of 82 bytes of data. Byte 1 to 4, 81 and 82 are the message header and bytes 5 to 80 contain six data elements. These messages use the SAPI/TEI value of 0x15 to differentiate themselves from the performance report message.

6.7.5 Frame Structure

The message structure of message-oriented signal is shown in [Figure 35](#). Two format types are shown in the figure: format A for frames which are sending performance report message and format B for frames which containing a path or test signal identification message. The following abbreviations are used:

- SAPI: Service Access Point Identifier
- C/R: Command or Response
- EA: Extended Address
- TEI: Terminal Endpoint Identifier
- FCS: Frame Check Sequence

6.7.6 Flag Sequence

All frames shall start and end with the flag sequence consisting of one 0 bit followed by six contiguous 1 bits and one 0 bit. The flag preceding the address field is defined as the opening flag. The flag following the Frame Check Sequence (FCS) field is defined as the closing flag. The closing flag may also serve as the opening flag

of the next frame, in some applications. However, all receivers must be able to accommodate receipt of one or more consecutive flags.

6.7.7 Address Field

The address field consists of two octets. A single octet address field is reserved for LAPB operation in order to allow a single LAPB data link connection to be multiplexed along with LAPD data link connections.

6.7.8 Address Field Extension bit (EA)

The address field range is extended by reserving bit 1 of the address field octets to indicate the final octet of the address field. The presence of a 1 in bit 1 of an address field octet signals that it is the final octet of the address field. The double octet address field for LAPD operation shall have bit 1 of the first octet set to a 0 and bit 1 of the second octet set to 1.

6.7.9 Command or Response bit (C/R)

The Command or Response bit identifies a frame as either a command or a response. The user side shall send commands with the C/R bit set to 0, and responses with the C/R bit set to 1. The network side shall do the opposite; That is, commands are sent with C/R bit set to 1, and responses are sent with C/R bit set to 0.

6.7.10 Service Access Point Identifier (SAPI)

The Service Access Point Identifier identifies a point at which data link layer services are preceded by a data link layer entity type to a layer 3 or management entity. Consequently, the SAPI specifies a data link layer entity type that should process a data link layer frame and also a layer 3 or management entity, which is to receive information carried by the data link layer frame. The SAPI allows 64 service access points to be specified, where bit 3 of the address field octet containing the SAPI is the least significant binary digit and bit 8 is the most significant. SAPI values are 0x14 and 0x15 for performance report message and path or test signal identification message respectively.

6.7.11 Terminal Endpoint Identifier (TEI)

The TEI sub-field allows 128 values where bit 2 of the address field octet containing the TEI is the least significant binary digit and bit 8 is the most significant binary digit. The TEI sub-field bit pattern 111 1111 (=127) is defined as the group TEI. The group TEI is assigned permanently to the broadcast data link connection associated with the addressed Service Access Point (SAP). TEI values other than 127 are used for the point-to-point data link connections associated with the addressed SAP. Non-automatic TEI values (0-63) are selected by the user, and their allocation is the responsibility of the user. The network automatically selects and allocates TEI values (64-126).

6.7.12 Control Field

The control field identifies the type of frame which will be either a command or response. The control field shall consist of one or two octets. Three types of control field formats are specified: 2-octet numbered information transfer (I format), 2-octet supervisory functions (S format), and single-octet unnumbered information transfers and control functions (U format). The control field for T1/E1 message is categorized as a single-octet unacknowledged information transfer having the value 0x03.

6.7.13 Frame Check Sequence (FCS) Field

The source of either the performance report or an identification message shall generate the frame check sequence. The FCS field shall be a 16-bit sequence. It shall be the ones complement of the sum (modulo 2) of:

- The remainder of $x^k (x^{15} + x^{14} + x^{13} + x^{12} + x^{11} + x^{10} + x^9 + x^8 + x^7 + x^6 + x^5 + x^4 + x^3 + x^2 + x + 1)$ divided (modulo 2) by the generator polynomial $x^{16} + x^{12} + x^5 + 1$, where k is the number of bits in the frame existing between, but not including, the final bit of the opening flag and the first bit of the FCS, excluding bits inserted for transparency, and
- The remainder of the division (modulo 2) by the generator polynomial $x^{16} + x^{12} + x^5 + 1$, of the product of x^{16} by the content of the frame existing between, but not including, the final bit of the opening flag and the first bit of the FCS, excluding bits inserted for transparency.

As a typical implementation at the transmitter, the initial content of the register of the device computing the remainder of the division is preset to all 1s and is then modified by division by the generator polynomial on the

SINGLE T1/E1/J1 FRAMER/LIU COMBO

address, control and information fields; the ones complement of the resulting remainder is transmitted as the 16-bit FCS.

As a typical implementation at the receiver, the initial content of the register of the device computing the remainder is preset to all 1s. The final remainder, after multiplication by x^{16} and then division (modulo 2) by the generator polynomial $x^{16} + x^{12} + x^5 + 1$ of the serial incoming protected bits and the FCS, will be 0001110100001111 (x^{15} through x^0 , respectively) in the absence of transmission errors.

6.7.14 Transparency (Zero Stuffing)

A transmitting data link layer entity shall examine the frame content between the opening and closing flag sequences, (address, control, information and FCS field) and shall insert a 0 bit after all sequences of five contiguous 1 bits (including the last five bits of the FCS) to ensure that an IDLE flag or an Abort sequence is not simulated within the frame. A receiving data link layer entity shall examine the frame contents between the opening and closing flag sequences and shall discard any 0 bit which directly follows five contiguous 1 bits.

6.8 Transmit SLC@96 Data link Controller

The SLC@96 T1 format is invented by AT&T and is used between the Digital Switch and a SLC@96 formatted remote terminal. The purpose of the SLC@96 product is to provide standard telephone service or Plain Old Telephone Service (POTS) in areas of high subscriber density but back-haul the traffic over T1 facilities.

To support the SLC@96 formatted remote terminal equipment, which is likely in an underground location, the T1 framer must:

- Indicate equipment failures of the equipment to maintenance personal
- Indicate failures of the POTS lines
- Test the POTS lines
- Provide redundancy on the T1s

The SLC@96 framing format is a D4 Super-frame (SF) format with specialized data link information bits. These data link information bits take the position of the Super-frame Alignment (Fs) bit positions. These bits consist of the following.

- Concentrator bits (C, bit position 1 to 11)
- First Spoiler bits (FS, bit position 12 to 14)
- Maintenance bits (M, bit position 15 to 17)
- Alarm bits (A, bit position 18 to 19)
- Protection Line Switch bits (S, bit position 20 to 23)
- Second Spoiler bit (SS, bit position 24)
- Resynchronization pattern (000111000111)

In SLC@96 mode, a six 6-bit datalink message will generate a one 9-ms frame of the SLC@96 message format. The format of the datalink message is given in BELLCORE TR-TSY-000008. When SLC@96 mode is enabled, the Fs bit is replaced by the data link message read from memory at the beginning of each D4 super-frame. The XRT86L30 allocates two 6-byte buffers to provide the SLC@96 Data Link Controller an alternating access mechanism for information transmission. The bit ordering and usage is shown in the following table; and the LSB is sent first. Note that these registers are memory-based storage and they need to be initialized.

TRANSMIT SLC@96 MESSAGE REGISTERS

BYTE	5	4	3	2	1	0
1	0	1	1	1	0	0
2	C1	1	1	1	0	0
3	C7	C6	C5	C4	C3	C2
4	1	0	C11	C10	C9	C8
5	A2	A1	M3	M2	M1	0
6	0	1	S4	S3	S2	S1

Each register is read out of memory once every six SF super-frames. The memory holding these registers owns a shared memory structure that is used by multiple devices. These include DS1 transmit module, DS1 receive module, Transmit LAPD Controller, Transmit SLC@96 Data Link controller, Bit-Oriented Signaling Processor, Receive LAPD Controller, Receive SLC@96 Data Link Controller, Receive Bit-Oriented Signaling Processor and microprocessor interface module.

SINGLE T1/E1/J1 FRAMER/LIU COMBO

6.9 D/E Time Slot Transmit HDLC Controller Block V5.1 or V5.2 Interface

V5.2 protocol specifies a provision for transmitting simultaneous LAPD messages. Since only one message can be sent through the datalink bits at one time, an alternative path for communication is offered within the framer block. This alternative path is known as D or E channel which can be transmitted through one or more of the DS-0 time slots. D channel is used primarily for data link applications. E channel is used primarily for signaling for circuit switching with multiple access configurations. A range of time slots can be dedicated to HDLC1, while a different range of time slots can be dedicated to HDLC2 to support V5.2. In addition, HDLC3 can be used to transmit a third LAPD message if desired. The HDLC controllers are implemented in the same manner as the datalink described above with the exception of the data link source select bits.

6.10 Automatic Performance Report (APR)

The APR feature allows the system to transmit PMON status within a LAPD Framing format A at one second intervals or within a single shot report. The data octets 5 through 12 within the LAPD frame are replaced with the PMON status for the previous one second interval.

TABLE 169: FRAMING FORMAT FOR PMON STATUS INSERTED WITHIN LAPD BY INITIATING APR

Octet Number	8	7	6	5	4	3	2	1	Time (s)
1	Flag = 01111110								
2	SAPI = 001110						CR	EA=0	
3	TEI = 0000000							EA=1	
4	Control = 00000011 = Unacknowledged Frame								
5	G3	LV	G4	U1	U2	G5	SL	G6	T ₀
6	FE	SE	LB	G1	R	G2	Nm	Ni	
7	G3	LV	G4	U1	U2	G5	SL	G6	T ₀ - 1
8	FE	SE	LB	G1	R	G2	Nm	Ni	
9	G3	LV	G4	U1	U2	G5	SL	G6	T ₀ - 2
10	FE	SE	LB	G1	R	G2	Nm	Ni	
11	G3	LV	G4	U1	U2	G5	SL	G6	T ₀ - 3
12	FE	SE	LB	G1	R	G2	Nm	Ni	
13	FCS								
14	FCS								
15	Flag = 01111110								

NOTE: The right most bit (bit 1) is transmitted first for all fields except for the two bytes of the FCS that are transmitted left most bit (bit 8) first.

6.10.1 Bit Value Interpretation

- G1 = 1 if number of CRC error events is equal to 1
- G2 = 1 if number of CRC error events is greater than 1 or equal to 5
- G3 = 1 if number of CRC error events is greater than 5 or equal to 10
- G4 = 1 if number of CRC error events is greater than 10 or equal to 100
- G5 = 1 if number of CRC error events is greater than 100 or equal to 319
- G6 = 1 if number of CRC error events is equal to 320
- SE = 1 if a severely errored framing event occurs (FE shall be 0)
- FE = 1 if a framing synchronization bit error event occurs (SE shall be 0)
- LV = 1 if a line code violation event occurs
- SL = 1 if slip event within the slip buffer occurs
- LB = 1 if payload loopback is activated
- U1 = Not Used (default = 0)

U2 = Not Used (default = 0)

R = Not Used (default = 0)

NmNi = One second report module 4 count

7.0 OVERHEAD INTERFACE BLOCK

The XRT86L30 has the ability to extract or insert DS1 data link information from or into the following:

- Facility Data Link (FDL) bits in ESF framing format mode
- Signaling Framing (Fs) bits in SLC@96 and N framing format mode
- Remote Signaling (R) bits in T1DM framing format mode

The source and destination of these inserted and extracted data link bits would be from either the internal HDLC Controller or the external device accessible through DS1 Overhead Interface Block. The operation of the Transmit Overhead Input Interface Block and the Receive Overhead Output Interface Block will be discussed separately.

7.1 DS1 Transmit Overhead Input Interface Block

7.1.1 Description of the DS1 Transmit Overhead Input Interface Block

The DS1 Transmit Overhead Input Interface Block will allow an external device to be the provider of the Facility Data Link (FDL) bits in ESF framing format mode, Signaling Framing (Fs) bits in the SLC96 and N framing format mode and Remote Signaling (R) bit in T1DM framing format mode. This interface provides interface signals and required interface timing to shift in proper data link information at proper time.

The Transmit Overhead Input Interface for a given Framer consists of two signals.

- TxOHClk_n: The Transmit Overhead Input Interface Clock Output signal
- TxOH_n: The Transmit Overhead Input Interface Input signal.

The Transmit Overhead Input Interface Clock Output pin (TxOHCLK_n) generates a rising clock edge for each data link bit position according to configuration of the framer. The Data Link equipment interfaced to the Transmit Overhead Input Interface block should update the data link bits on the TxOH_n line upon detection of the rising edge of TxOHClk_n. The Transmit Overhead Input Interface block will sample and latch the data link bits on the TxOH_n line on the falling edge of TxOHClk_n. The data link bits will be included and transmitted via the outgoing DS1 frames.

The figure below shows block diagram of the DS1 Transmit Overhead Input Interface of XRT86L30.

FIGURE 36. BLOCK DIAGRAM OF THE DS1 TRANSMIT OVERHEAD INPUT INTERFACE OF THE XRT86L30

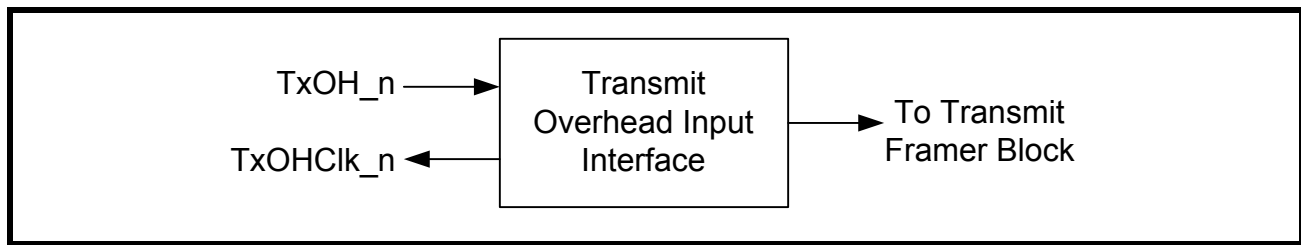

7.1.2 Configure the DS1 Transmit Overhead Input Interface module as source of the Facility Data Link (FDL) bits in ESF framing format mode

The FDL bits in ESF framing format mode can be inserted from:

- DS1 Transmit Overhead Input Interface Block
- DS1 Transmit HDLC Controller
- DS1 Transmit Serial Input Interface.

The Transmit Data Link Source Select bits of the Transmit Data Link Select Register (TDLSR) controls the insertion of data link bits into the FDL bits in ESF framing format mode. The table below shows configuration of the Transmit Data Link Source Select bits of the Transmit Data Link Select Register (TDLSR).

TRANSMIT DATA LINK SELECT REGISTER (TDLSR) (ADDRESS = 0X010AH)

BIT NUMBER	BIT NAME	BIT TYPE	BIT DESCRIPTION
1-0	Transmit Data Link Source Select	R/W	00 - The Facility Data Link bits are inserted into the framer through either the LAPD controller or the SLC@96 buffer. 01 - The Facility Data Link bits are inserted into the framer through the Transmit Serial Data input Interface via the TxSer_n pins. 10 - The Facility Data Link bits are inserted into the framer through the Transmit Overhead Input Interface via the TxOH_n pins. 11 - The Facility Data Link bits are forced to one by the framer.

If the Transmit Data Link Source Select bits of the Transmit Data Link Select Register are set to 10, the Transmit Overhead Input Interface Block becomes input source of the FDL bits.

The XRT86L30 allows the user to select bandwidth of the Facility Data Link Channel in ESF framing format mode. The FDL can be either a 4KHz or 2KHz data link channel. The Transmit Data Link Bandwidth Select bits of the Transmit Data Link Select Register (TDLSR) determine the bandwidth of FDL channel in ESF framing format mode.

The table below shows configuration of the Transmit Data Link Bandwidth Select bits of the Transmit Data Link Select Register (TDLSR.)

TRANSMIT DATA LINK SELECT REGISTER (TDLSR) (ADDRESS = 0X010AH)

BIT NUMBER	BIT NAME	BIT TYPE	BIT DESCRIPTION
5-4	Transmit Data Link Bandwidth Select	R/W	00 - The Facility Data Link is a 4KHz channel. All available FDL bits (first bit of every other frame) are used as data link bits. 01 - The Facility Data Link is a 2KHz channel. Only the odd FDL bits (first bit of frame 1, 5, 9...) are used as data link bits. 10 - The Facility Data Link is a 2KHz channel. Only the even FDL bits (first bit of frame 3, 7, 11...) are used as data link bits.

Figure 37 below shows the timing diagram of the input and output signals associated with the DS1 Transmit Overhead Input Interface module in ESF framing format mode.

FIGURE 37. DS1 TRANSMIT OVERHEAD INPUT INTERFACE TIMING IN ESF FRAMING FORMAT MODE

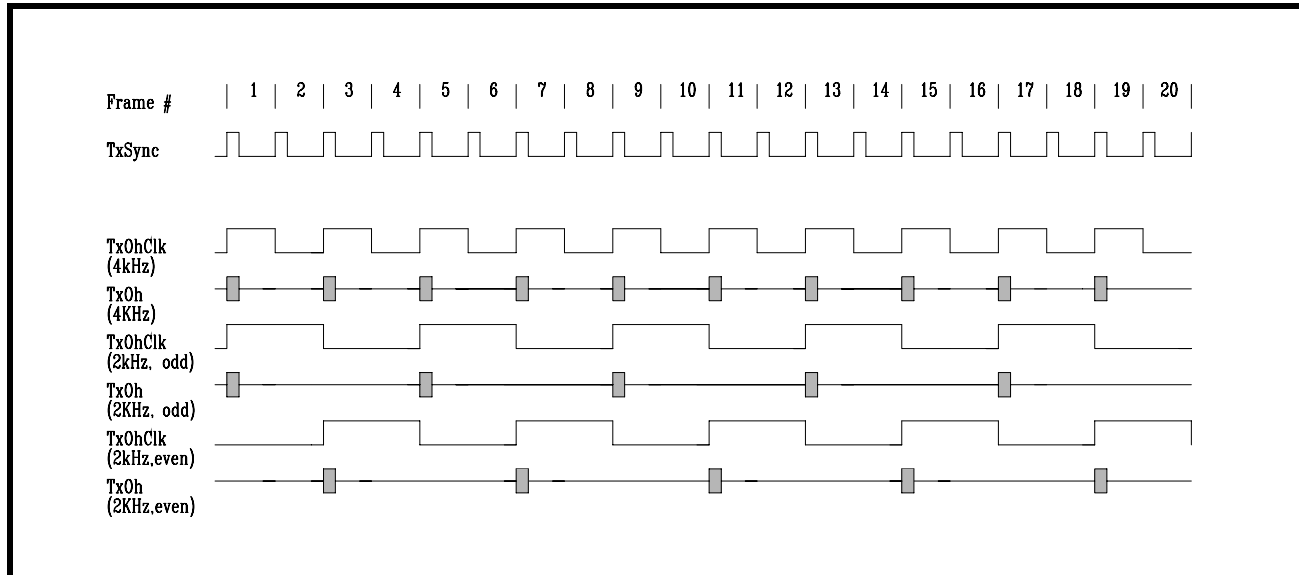

7.1.3 Configure the DS1 Transmit Overhead Input Interface module as source of the Signaling Framing (Fs) bits in N or SLC@96 framing format mode

The Fs bits in SLC@96 and N framing format mode can be inserted from:

- DS1 Transmit Overhead Input Interface Block
- DS1 Transmit HDLC Controller
- DS1 Transmit Serial Input Interface.

The Transmit Data Link Source Select bits of the Transmit Data Link Select Register (TDLSR) controls the insertion of data link bits into the Fs bits in N or SLC@96 framing format mode. The table below shows configuration of the Transmit Data Link Source Select bits of the Transmit Data Link Select Register (TDLSR).

TRANSMIT DATA LINK SELECT REGISTER (TDLSR) (ADDRESS = 0X010AH)

BIT NUMBER	BIT NAME	BIT TYPE	BIT DESCRIPTION
1-0	Transmit Data Link Source Select	R/W	00 - The Signaling Framing bits are inserted into the framer through either the LAPD controller or the SLC@96 buffer. 01 - The Signaling Framing bits are inserted into the framer through the Transmit Serial Data input Interface via the TxSer_n pins. 10 - The Signaling Framing bits are inserted into the framer through the Transmit Overhead Input Interface via the TxOH_n pins. 11 - The Signaling Framing bits are forced to one by the framer.

If the Transmit Data Link Source Select bits of the Transmit Data Link Select Register are set to 10, the Transmit Overhead Input Interface Block becomes input source of the Fs bits.

Figure 38 below shows the timing diagram of the input and output signals associated with the DS1 Transmit Overhead Input Interface module in N or SLC@96 framing format mode.

FIGURE 38. DS1 TRANSMIT OVERHEAD INPUT TIMING IN N OR SLC@96 FRAMING FORMAT MODE

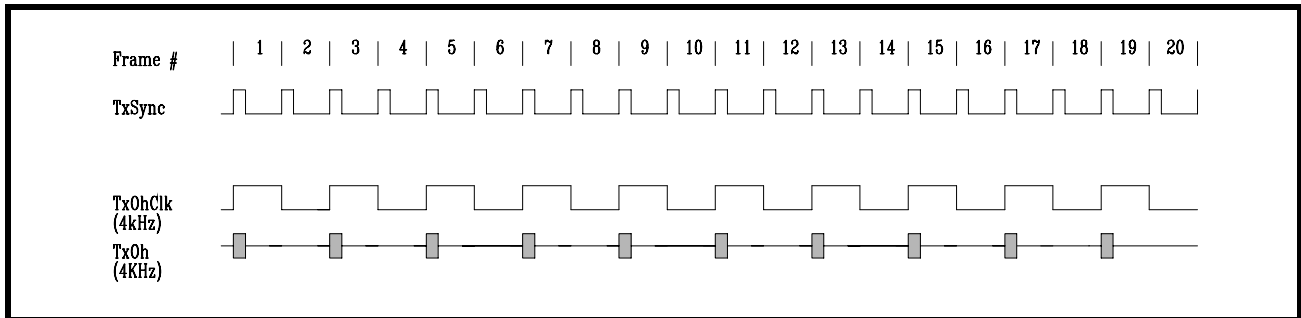

7.1.4 Configure the DS1 Transmit Overhead Input Interface module as source of the Remote Signaling (R) bits in T1DM framing format mode

The R bits in T1DM framing format mode can be inserted from:

- DS1 Transmit Overhead Input Interface Block
- DS1 Transmit HDLC Controller
- DS1 Transmit Serial Input Interface.

The Transmit Data Link Source Select bits of the Transmit Data Link Select Register (TDLSR) controls the insertion of data link bits into the R bits in T1DM framing format mode. The table below shows configuration of the Transmit Data Link Source Select bits of the Transmit Data Link Select Register (TDLSR).

TRANSMIT DATA LINK SELECT REGISTER (TDLSR) (ADDRESS = 0X010AH)

BIT NUMBER	BIT NAME	BIT TYPE	BIT DESCRIPTION
1-0	Transmit Data Link Source Select	R/W	00 - The Remote Signaling bits are inserted into the framer through either the LAPD controller or the SLC@96 buffer. 01 - The Remote Signaling bits are inserted into the framer through the Transmit Serial Data input Interface via the TxSer_n pins. 10 - The Remote Signaling bits are inserted into the framer through the Transmit Overhead Input Interface via the TxOH_n pins. 11 - The Remote Signaling bits are forced to one by the framer.

If the Transmit Data Link Source Select bits of the Transmit Data Link Select Register are set to 10, the Transmit Overhead Input Interface Block becomes input source of the R bits. Since R bit presents in Timeslot 24 of every T1DM frame, therefore, bandwidth of T1DM data link channel is 8KHz.

Figure 39 below shows the timing diagram of the input and output signals associated with the DS1 Transmit Overhead Input Interface module in T1DM framing format mode.

FIGURE 39. DS1 TRANSMIT OVERHEAD INPUT INTERFACE MODULE IN T1DM FRAMING FORMAT MODE

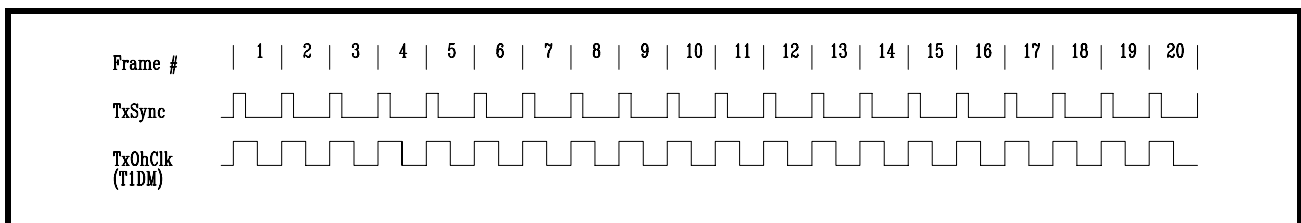

7.2 DS1 Receive Overhead Output Interface Block

7.2.1 Description of the DS1 Receive Overhead Output Interface Block

The DS1 Receive Overhead Output Interface Block allows an external device to be the consumer of the Facility Data Link (FDL) bits in ESF framing format mode, Signaling Framing (Fs) bits in the SLC96 and N framing format mode and Remote Signaling (R) bit in T1DM framing format mode. This interface provides interface signals and required interface timing to shift out proper data link information at proper time.

The Receive Overhead Output Interface for a given Framer consists of two signals.

- RxOHClk_n: The Receive Overhead Output Interface Clock Output signal
- RxOH_n: The Receive Overhead Output Interface Output signal.

The Receive Overhead Output Interface Clock Output pin (RxOHCLK_n) generates a rising clock edge for each data link bit position according to configuration of the framer. The data link bits extracted from the incoming T1 frames are outputted from the Receive Overhead Output Interface Output pin (RxOH_n) at the rising edge of RxOHClk_n. The Data Link equipment should sample and latch the data link bits at the falling edge of RxOHClk_n.

The figure below shows block diagram of the Receive Overhead Output Interface of XRT86L30.

FIGURE 40. BLOCK DIAGRAM OF THE DS1 RECEIVE OVERHEAD OUTPUT INTERFACE OF XRT86L30

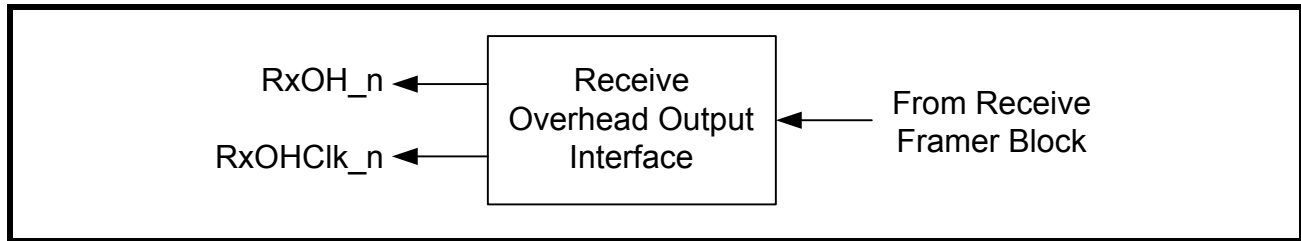

7.2.2 Configure the DS1 Receive Overhead Output Interface module as destination of the Facility Data Link (FDL) bits in ESF framing format mode

The FDL bits in ESF framing format mode can be extracted to:

- DS1 Receive Overhead Output Interface Block
- DS1 Receive HDLC Controller
- DS1 Receive Serial Output Interface.

The Receive Data Link Source Select bits of the Receive Data Link Select Register (RDLSR) controls the extraction of FDL bits in ESF framing format mode. The table below shows configuration of the Receive Data Link Source Select bits of the Receive Data Link Select Register (RDLSR).

RECEIVE DATA LINK SELECT REGISTER (TDLSR) (ADDRESS = 0X010AH)

BIT NUMBER	BIT NAME	BIT TYPE	BIT DESCRIPTION
1-0	Receive Data Link Destination Select	R/W	00 - The extracted Facility Data Link bits are stored in either the LAPD controller or the SLC@96 buffer. At the same time, the extracted Facility Data Link bits are outputted from the framer through the Receive Serial Data Output Interface via the RxSer_n pins. 01 - The extracted Facility Data Link bits are outputted from the framer through the Receive Serial Data Output Interface via the RxSer_n pins. 10 - The extracted Facility Data Link bits are outputted from the framer through the Receive Overhead Output Interface via the RxOH_n pins. At the same time, the extracted Facility Data Link bits are outputted from the framer through the Receive Serial Data Output Interface via the RxSer_n pins. 11 - The Facility Data Link bits are forced to one by the framer.

If the Receive Data Link Source Select bits of the Receive Data Link Select Register are set to 10, the Receive Overhead Output Interface Block becomes Output source of the FDL bits.

The XRT86L30 allows the user to select bandwidth of the Facility Data Link Channel in ESF framing format mode. The FDL can be either a 4KHz or 2KHz data link channel. The Receive Data Link Bandwidth Select bits of the Receive Data Link Select Register (RDLSR) determine the bandwidth of FDL channel in ESF framing format mode.

The table below shows configuration of the Receive Data Link Bandwidth Select bits of the Receive Data Link Select Register (TDLSR).

RECEIVE DATA LINK SELECT REGISTER (TDLSR) (ADDRESS = 0X010AH)

BIT NUMBER	BIT NAME	BIT TYPE	BIT DESCRIPTION
5-4	Receive Data Link Bandwidth Select	R/W	00 - The Facility Data Link is a 4KHz channel. All available FDL bits (first bit of every other frame) are used as data link bits. 01 - The Facility Data Link is a 2KHz channel. Only the odd FDL bits (first bit of frame 1, 5, 9...) are used as data link bits. 10 - The Facility Data Link is a 2KHz channel. Only the even FDL bits (first bit of frame 3, 7, 11...) are used as data link bits.

Figure 41 below shows the timing diagram of the Output and output signals associated with the DS1 Receive Overhead Output Interface module in ESF framing format mode.

FIGURE 41. DS1 RECEIVE OVERHEAD OUTPUT INTERFACE MODULE IN ESF FRAMING FORMAT MODE

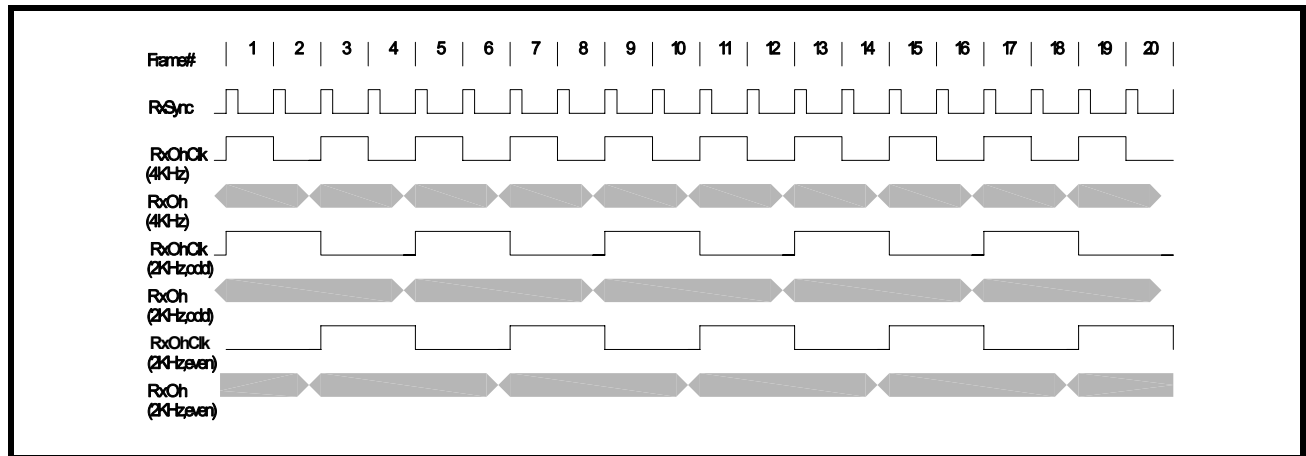

7.2.3 Configure the DS1 Receive Overhead Output Interface module as destination of the Signaling Framing (Fs) bits in N or SLC@96 framing format mode

The Fs bits in SLC@96 and N framing format mode can be extracted to:

- DS1 Receive Overhead Output Interface Block
- DS1 Receive HDLC Controller
- DS1 Receive Serial Output Interface.

SINGLE T1/E1/J1 FRAMER/LIU COMBO

The Receive Data Link Source Select bits of the Receive Data Link Select Register (RDLSR) controls the destination of Fs bits in N or SLC@96 framing format mode. The table below shows configuration of the Receive Data Link Source Select bits of the Receive Data Link Select Register (RDLSR).

RECEIVE DATA LINK SELECT REGISTER (TDLSR) (ADDRESS = 0X010AH)

BIT NUMBER	BIT NAME	BIT TYPE	BIT DESCRIPTION
1-0	Receive Data Link Source Select	R/W	00 - The extracted Facility Data Link bits are stored in either the LAPD controller or the SLC@96 buffer. At the same time, the extracted Facility Data Link bits are outputted from the framer through the Receive Serial Data Output Interface via the RxSer_n pins. 01 - The extracted Facility Data Link bits are outputted from the framer through the Receive Serial Data Output Interface via the RxSer_n pins. 10 - The extracted Facility Data Link bits are outputted from the framer through the Receive Overhead Output Interface via the RxOH_n pins. At the same time, the extracted Facility Data Link bits are outputted from the framer through the Receive Serial Data Output Interface via the RxSer_n pins. 11 - The Facility Data Link bits are forced to one by the framer.

If the Receive Data Link Source Select bits of the Receive Data Link Select Register are set to 10, the Receive Overhead Output Interface Block outputs Fs bits extracted from the incoming T1 data stream.

Figure 42 below shows the timing diagram of the output signals associated with the DS1 Receive Overhead Output Interface module in N or SLC@96 framing format mode.

FIGURE 42. DS1 RECEIVE OVERHEAD OUTPUT INTERFACE TIMING IN N OR SLC@96 FRAMING FORMAT MODE

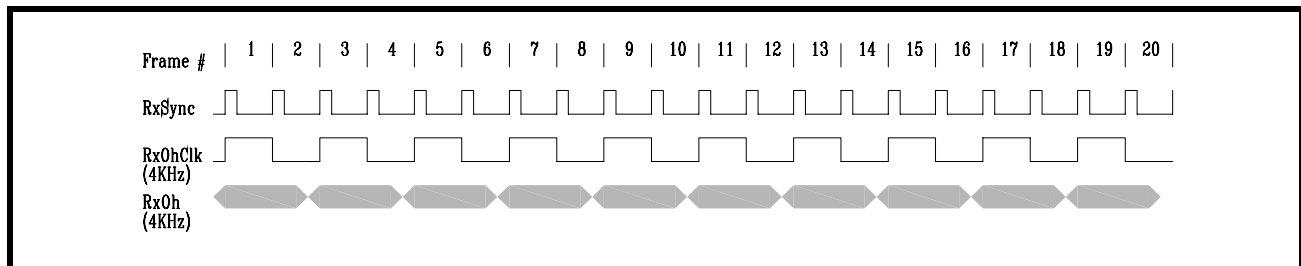

7.2.4 Configure the DS1 Receive Overhead Output Interface module as destination of the Remote Signaling (R) bits in T1DM framing format mode

The R bits in T1DM framing format mode can be extracted to:

- DS1 Receive Overhead Output Interface Block
- DS1 Receive HDLC Controller
- DS1 Receive Serial Output Interface.

The Receive Data Link Source Select bits of the Receive Data Link Select Register (RDLSR) controls the destination of R bits in T1DM framing format mode. The table below shows configuration of the Receive Data Link Source Select bits of the Receive Data Link Select Register (RDLSR).

RECEIVE DATA LINK SELECT REGISTER (RDLSR) (ADDRESS = 0X010AH)

BIT NUMBER	BIT NAME	BIT TYPE	BIT DESCRIPTION
1-0	Receive Data Link Source Select	R/W	<p>00 - The extracted Facility Data Link bits are stored in either the LAPD controller or the SLC@96 buffer. At the same time, the extracted Facility Data Link bits are outputted from the framer through the Receive Serial Data Output Interface via the RxSer_n pins.</p> <p>01 - The extracted Facility Data Link bits are outputted from the framer through the Receive Serial Data Output Interface via the RxSer_n pins.</p> <p>10 - The extracted Facility Data Link bits are outputted from the framer through the Receive Overhead Output Interface via the RxOH_n pins. At the same time, the extracted Facility Data Link bits are outputted from the framer through the Receive Serial Data Output Interface via the RxSer_n pins.</p> <p>11 - The Facility Data Link bits are forced to one by the framer.</p>

If the Receive Data Link Source Select bits of the Receive Data Link Select Register are set to 10, the Receive Overhead Output Interface Block outputs the R bits extracted from the incoming T1 data stream. Since R bit presents in Timeslot 24 of every T1DM frame, therefore, bandwidth of T1DM data link channel is 8KHz.

Figure 43 below shows the timing diagram of the output signals associated with the DS1 Receive Overhead Output Interface module in T1DM framing format mode.

FIGURE 43. DS1 RECEIVE OVERHEAD OUTPUT INTERFACE TIMING IN T1DM FRAMING FORMAT MODE

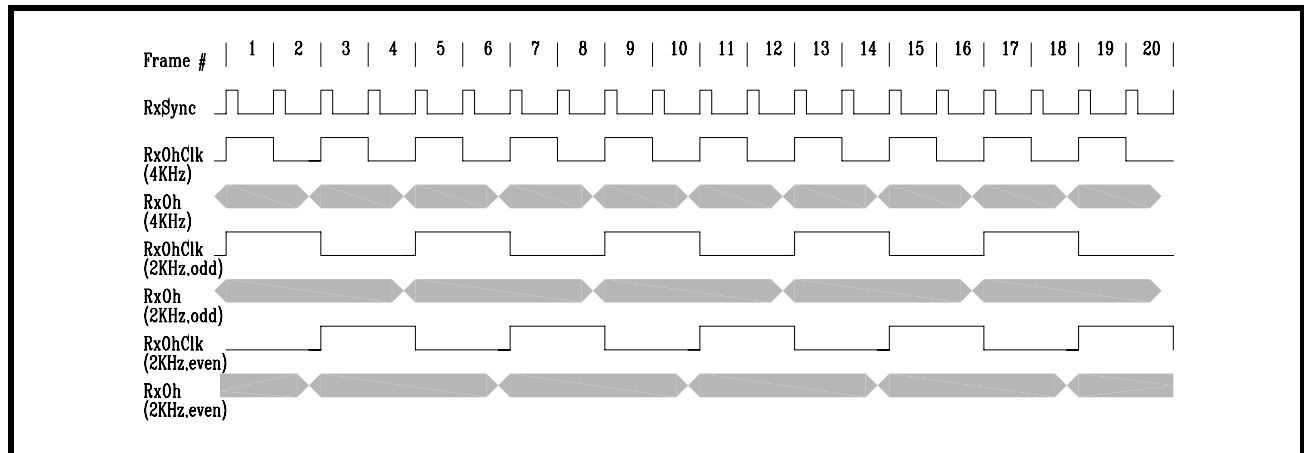

7.3 E1 Overhead Interface Block

The XRT86L30 has the ability to extract or insert E1 data link information from or into the E1 National bit sequence. The source and destination of these inserted and extracted data link bits would be from either the internal HDLC Controller or the external device accessible through E1 Overhead Interface Block. The operation of the Transmit Overhead Input Interface Block and the Receive Overhead Output Interface Block will be discussed separately.

7.4 E1 Transmit Overhead Input Interface Block

7.4.1 Description of the E1 Transmit Overhead Input Interface Block

The E1 Transmit Overhead Input Interface Block will allow an external device to be the provider of the E1 National bit sequence. This interface provides interface signals and required interface timing to shift in proper data link information at proper time.

The Transmit Overhead Input Interface for a given Framer consists of two signals.

- TxOHClk_n: The Transmit Overhead Input Interface Clock Output signal
- TxOH_n: The Transmit Overhead Input Interface Input signal.

The Transmit Overhead Input Interface Clock Output pin (TxOHCLK_n) generates a rising clock edge for each National bit that is configured to carry Data Link information according to setting of the framer. The Data Link equipment interfaced to the Transmit Overhead Input Interface should update the data link bits on the TxOH_n line upon detection of the rising edge of TxOHClk_n. The Transmit Overhead Input Interface block will sample and latch the data link bits on the TxOH_n line on the falling edge of TxOHClk_n. The data link bits will be included in and transmitted via the outgoing E1 frames.

The figure below shows block diagram of the DS1 Transmit Overhead Input Interface of XRT86L30.

FIGURE 44. BLOCK DIAGRAM OF THE E1 TRANSMIT OVERHEAD INPUT INTERFACE OF XRT86L30

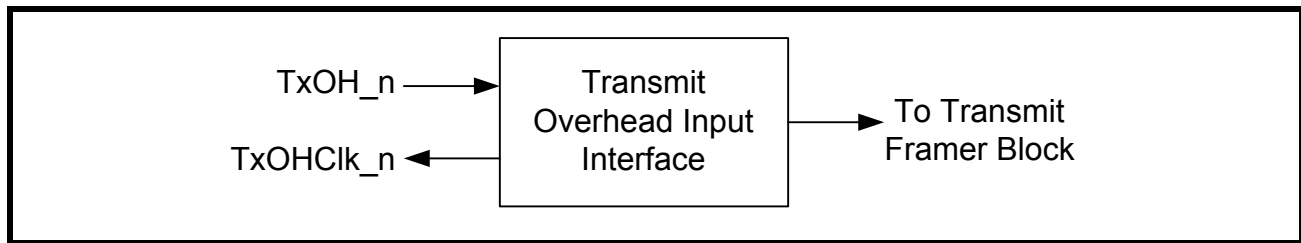

7.4.2 Configure the E1 Transmit Overhead Input Interface module as source of the National Bit Sequence in E1 framing format mode

The National Bit Sequence in E1 framing format mode can be inserted from:

- E1 Transmit Overhead Input Interface Block
- E1 Transmit HDLC Controller
- E1 Transmit Serial Input Interface

The purpose of the Transmit Overhead Input Interface is to permit Data Link equipment direct access to the Sa4 through Sa8 National bits that are to be transported via the outbound frames. The Transmit Data Link Source Select [1:0] bits, within the Synchronization MUX Register (SMR) determine source of the Sa4 through Sa8 National bits to be inserted into the outgoing E1 frames.

The table below shows configuration of the Transmit Data Link Source Select [1:0] bits of the Synchronization MUX Register (SMR).

SYNCHRONIZATION MUX REGISTER (SMR) (ADDRESS = 0X0109H)

BIT NUMBER	BIT NAME	BIT TYPE	BIT DESCRIPTION
3-2	Transmit Data Link Source Select [1:0]	R/W	00 - The Sa4 through Sa8 National bits are inserted into the framer through the Transmit Serial Data input Interface via the TxSer_n pins. 01 - The Sa4 through Sa8 National bits are inserted into the framer through the Transmit LAPD Controller. 10 - The Sa4 through Sa8 National bits are inserted into the framer through the Transmit Overhead Input Interface via the TxOH_n pins. 11 - The Sa4 through Sa8 National bits are inserted into the framer through the Transmit Serial Data input Interface via the TxSer_n pins.

If the Transmit Data Link Source Select bits of the Transmit Data Link Select Register are set to 10, the Transmit Overhead Input Interface Block becomes input source of the FDL bits.

The XRT86L30 allows the user to decide on the following:

- How many of the National Bits will be used to carry the Data Link information bits
- Which of these National Bits will be used to carry the Data Link information bits.

The Transmit Sa Data Link Select bits of the Transmit Signaling and Data Link Select Register (TSDLSR) determine which ones of the National bits are configured as Data Link bits in E1 framing format mode. Depending upon the configuration of the Transmit Signaling and Data Link Select Register, either of the following cases may exist:

- None of the National bits are used to transport the Data Link information bits (That is, data link channel of XRT86L30 is inactive).
- Any combination of between 1 and all 5 of the National bits can be selected to transport the Data Link information bits.

The table below shows configuration of the Transmit Sa Data Link Select bits of the Transmit Signaling and Data Link Select Register (TSDLSR).

TRANSMIT SIGNALING AND DATA LINK SELECT REGISTER (TSDLSR) (ADDRESS = 0X010AH)

BIT NUMBER	BIT NAME	BIT TYPE	BIT DESCRIPTION
7	Transmit Sa8 Data Link Select	R/W	0 - Source of the Sa8 National bit is not from the data link interface. 1 - Source the Sa8 National bit from the data link interface.
6	Transmit Sa7 Data Link Select	R/W	0 - Source of the Sa7 National bit is not from the data link interface. 1 - Source the Sa7 National bit from the data link interface.
5	Transmit Sa6 Data Link Select	R/W	0 - Source of the Sa6 National bit is not from the data link interface. 1 - Source the Sa6 National bit from the data link interface.
4	Transmit Sa5 Data Link Select	R/W	0 - Source of the Sa5 National bit is not from the data link interface. 1 - Source the Sa5 National bit from the data link interface.
3	Transmit Sa4 Data Link Select	R/W	0 - Source of the Sa4 National bit is not from the data link interface. 1 - Source the Sa4 National bit from the data link interface.

For every Sa bit that is selected to carry Data Link information, the Transmit Overhead Input Interface will supply a clock pulse, via the TxOHClk_n output pin, such that:

- The Data Link equipment interfaced to the Transmit Overhead Input Interface should update the data on the TxOH_n line upon detection of the rising edge of TxOHClk_n.
- The Transmit Overhead Input Interface will sample and latch the data on the TxOH_n line on the falling edge of TxOHClk_n.

Figure 45 below shows the timing diagram of the input and output signals associated with the E1 Transmit Overhead Input Interface module in E1 framing format mode.

FIGURE 45. E1 TRANSMIT OVERHEAD INPUT INTERFACE TIMING

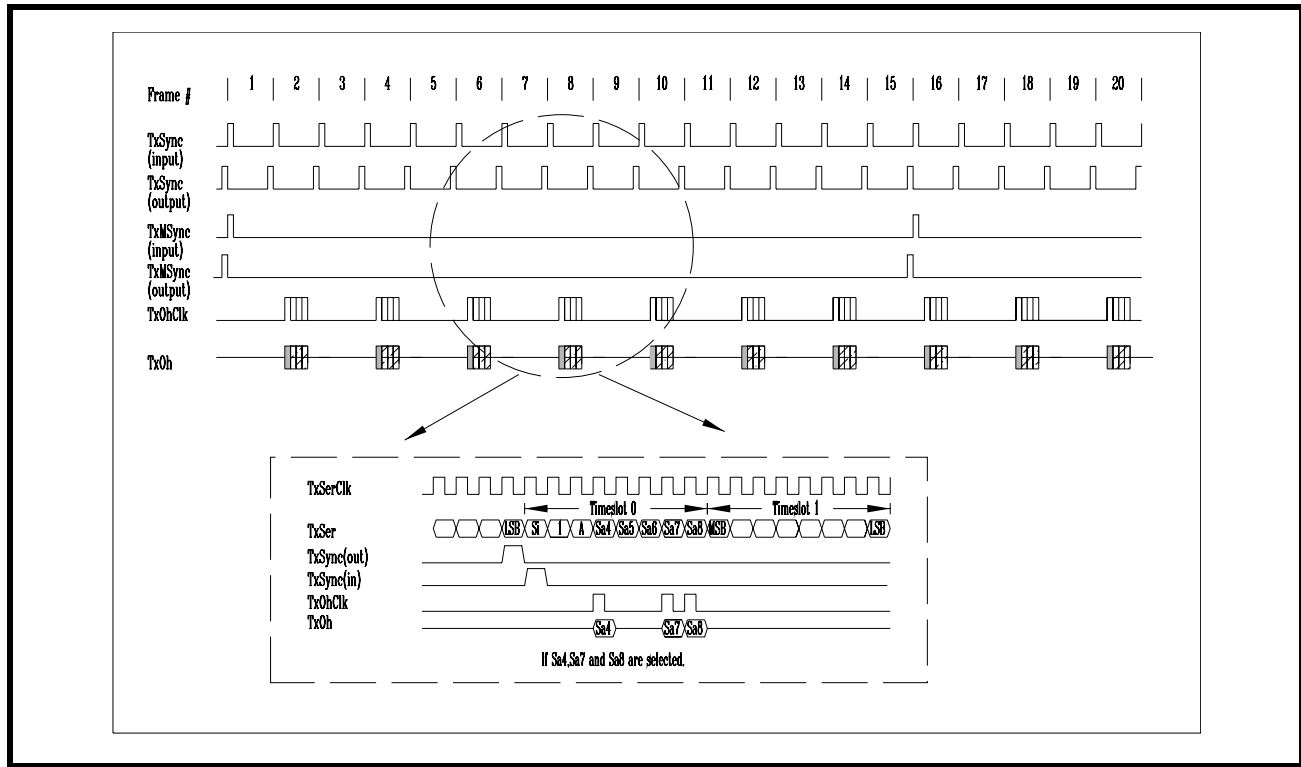

7.5 E1 Receive Overhead Interface

7.5.1 Description of the E1 Receive Overhead Output Interface Block

The E1 Receive Overhead Output Interface Block will allow an external device to be the consumer of the E1 National bit sequence. This interface provides interface signals and required interface timing to shift out proper data link information at proper time.

The Receive Overhead Output Interface for a given Framer consists of two signals.

- RxOHClk_n: The Receive Overhead Output Interface Clock Output signal
- RxOH_n: The Receive Overhead Output Interface Output signal.

The Receive Overhead Output Interface Clock Output pin (RxOHCLK_n) generates a rising clock edge for each National bit that is configured to carry Data Link information according to setting of the framer. The data link bits extracted from the incoming E1 frames are outputted from the Receive Overhead Output Interface Output pin (RxOH_n) before the rising edge of RxOHClk_n. The Data Link equipment should sample and latch the data link bits at the rising edge of RxOHClk_n.

The figure below shows block diagram of the Receive Overhead Output Interface of XRT86L30.

FIGURE 46. BLOCK DIAGRAM OF THE E1 RECEIVE OVERHEAD OUTPUT INTERFACE OF XRT86L30

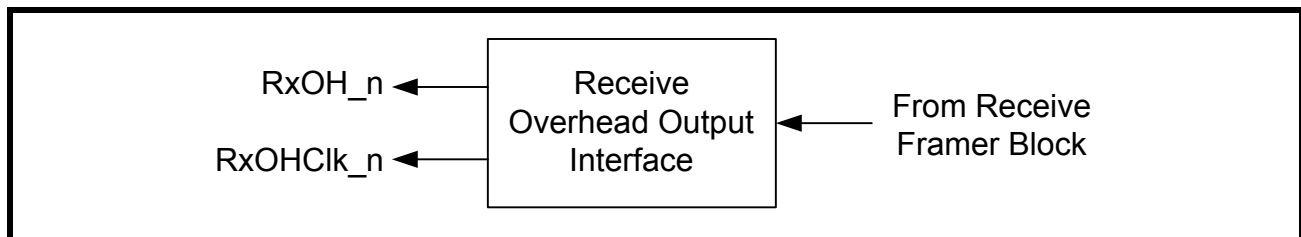

7.5.2 Configure the E1 Receive Overhead Output Interface module as source of the National Bit Sequence in E1 framing format mode

The National Bit Sequence in E1 framing format mode can be extracted and directed to:

- E1 Receive Overhead Output Interface Block
- E1 Receive HDLC Controller
- E1 Receive Serial Output Interface

The purpose of the Receive Overhead Output Interface is to permit Data Link equipment to have direct access to the Sa4 through Sa8 National bits that are extracted from the incoming E1 frames. Independent of the availability of the E1 Receive HDLC Controller module, the XRT86L30 always output the received National bits through the Receive Overhead Output Interface block.

The XRT86L30 allows the user to decide on the following:

- How many of the National Bits is used to carry the Data Link information bits
- Which of these National Bits is used to carry the Data Link information bits.

The Receive Sa Data Link Select bits of the Receive Signaling and Data Link Select Register (TSDLSR) determine which ones of the National bits are configured as Data Link bits in E1 framing format mode. Depending upon the configuration of the Receive Signaling and Data Link Select Register, either of the following cases may exists:

- None of the received National bits are used to transport the Data Link information bits (That is, data link channel of XRT86L30 is inactive).
- Any combination of between 1 and all 5 of the received National bits are used to transport the Data Link information bits.

The table below shows configuration of the Receive Sa Data Link Select bits of the Receive Signaling and Data Link Select Register (RSDLSR).

RECEIVE SIGNALING AND DATA LINK SELECT REGISTER (RSDLSR) (ADDRESS = 0X010CH)

BIT NUMBER	BIT NAME	BIT TYPE	BIT DESCRIPTION
7	Receive Sa8 Data Link Select	R/W	0 - The received Sa8 Nation bit is not extracted to the data link interface. 1 - The received Sa8 Nation bit is extracted to the data link interface.
6	Receive Sa7 Data Link Select	R/W	0 - The received Sa7 Nation bit is not extracted to the data link interface. 1 - The received Sa7 Nation bit is extracted to the data link interface.
5	Receive Sa6 Data Link Select	R/W	0 - The received Sa6 Nation bit is not extracted to the data link interface. 1 - The received Sa6 Nation bit is extracted to the data link interface.
4	Receive Sa5 Data Link Select	R/W	0 - The received Sa5 Nation bit is not extracted to the data link interface. 1 - The received Sa5 Nation bit is extracted to the data link interface.
3	Receive Sa4 Data Link Select	R/W	0 - The received Sa4 Nation bit is not extracted to the data link interface. 1 - The received Sa4 Nation bit is extracted to the data link interface.

For every received Sa bit that is determined to carry Data Link information, the Receive Overhead Output Interface will supply a clock pulse, via the RxOHClk_n output pin, such that:

- The Receive Overhead Output interface should update the data on the RxOH_n line before the rising edge of RxOHClk_n.
- The external Data Link equipment interfaced to the Receive Overhead Output Interface will sample and latch the data on the RxOH_n line on the rising edge of RxOHClk_n.

Figure 47 below shows the timing diagram of the output signals associated with the E1 Receive Overhead Output Interface module in E1 framing format mode.

FIGURE 47. E1 RECEIVE OVERHEAD OUTPUT INTERFACE TIMING

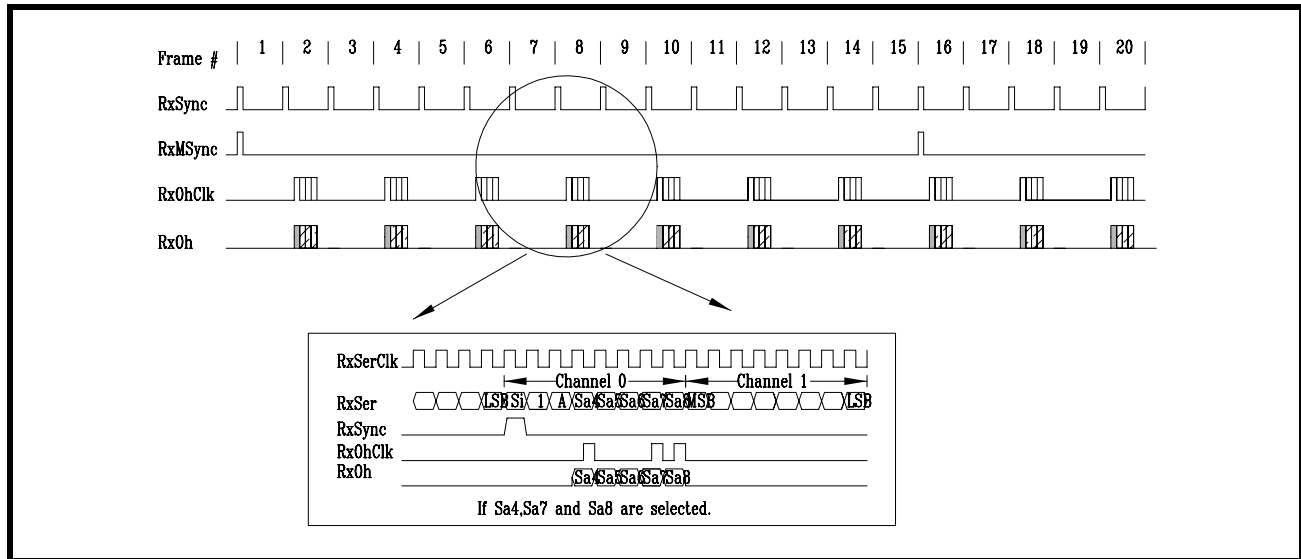

8.0 LIU TRANSMIT PATH

8.1 *Transmit Diagnostic Features*

In addition to TAOS, the XRT86L30 offers multiple diagnostic features for analyzing network integrity such as ATAOS, Network Loop Code generation, and QRSS on a per channel basis by programming the appropriate registers. These diagnostic features take priority over the digital data provided by the Framer block. The transmitters will send the diagnostic code to the line and will be maintained in the digital loopback if selected.

8.1.1 TAOS (Transmit All Ones)

The XRT86L30 has the ability to transmit all ones on a per channel basis by programming the appropriate channel register. This function takes priority over the digital data provided by the Framer block. For example: If a fixed "0011" pattern is provided by the Framer block and TAOS is enabled, the transmitter will output all ones. **Figure 48** is a diagram showing the all ones signal at TTIP and TRING.

FIGURE 48. TAOS (TRANSMIT ALL ONES)

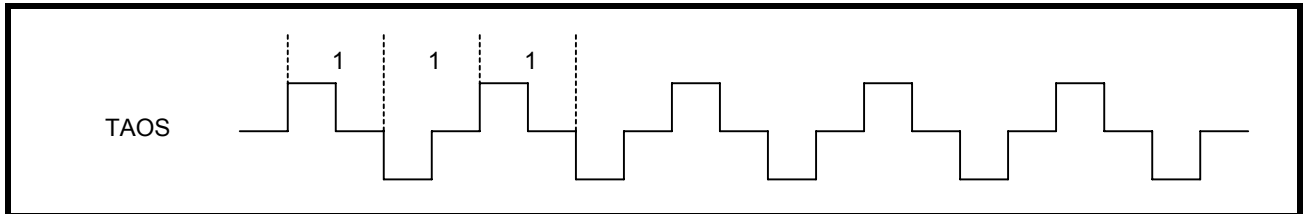

8.1.2 ATAOS (Automatic Transmit All Ones)

If ATAOS is selected by programming the appropriate global register, an AMI all ones signal will be transmitted for each channel that experiences an RLOS condition. If RLOS does not occur, the ATAOS will remain inactive until an RLOS on a given channel occurs. A simplified block diagram of the ATAOS function is shown in **Figure 49**.

FIGURE 49. SIMPLIFIED BLOCK DIAGRAM OF THE ATAOS FUNCTION

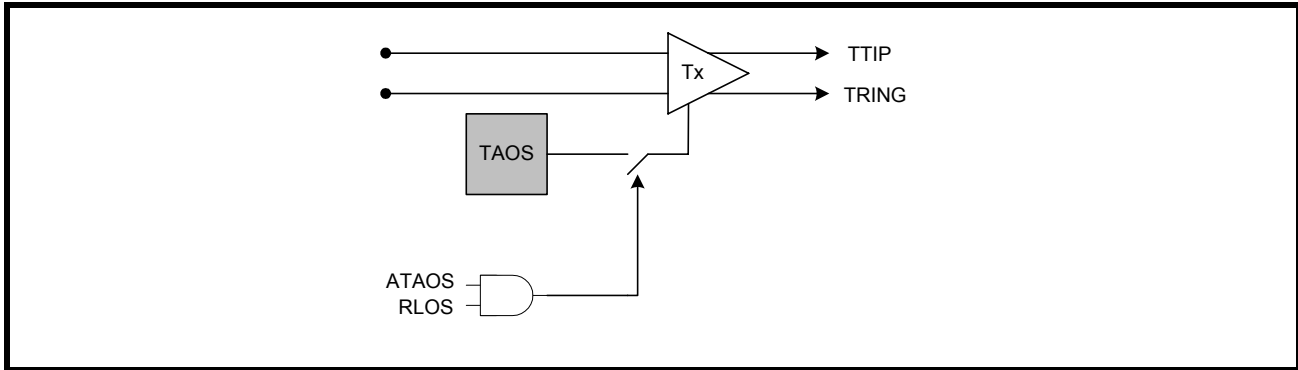

8.1.3 Network Loop Up Code

By setting the LIU to generate a NLUC, the transmitters will send out a repeating "00001" pattern. The output waveform is shown in **Figure 50**.

FIGURE 50. NETWORK LOOP UP CODE GENERATION

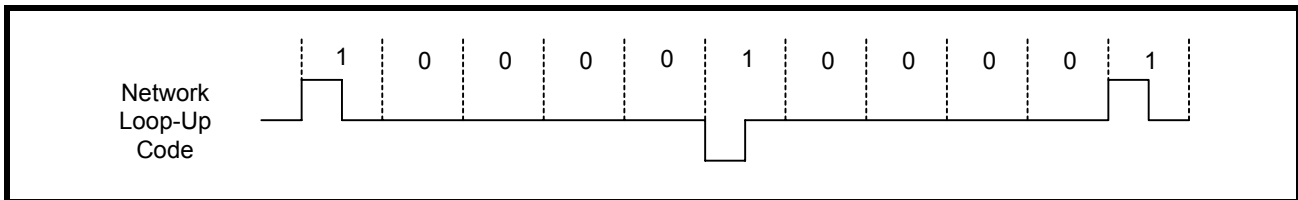

8.1.4 Network Loop Down Code

By setting the LIU to generate a NLDC, the transmitters will send out a repeating "001" pattern. The output waveform is shown in **Figure 51**.

FIGURE 51. NETWORK LOOP DOWN CODE GENERATION

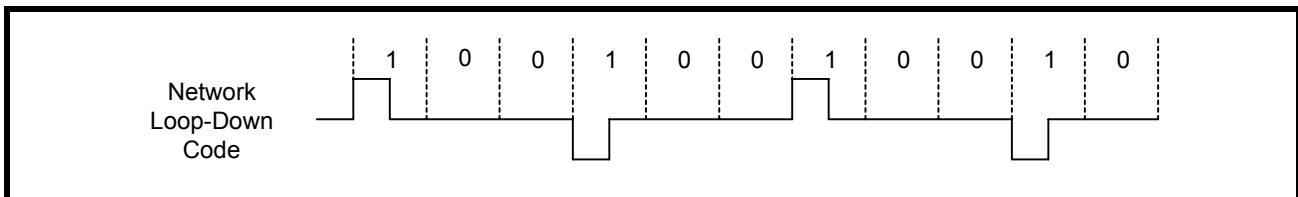

8.1.5 QRSS Generation

The XRT86L30 can transmit a QRSS random sequence to a remote location from TTIP/TRING. The polynomial is shown in **Table 170**.

TABLE 170: RANDOM BIT SEQUENCE POLYNOMIALS

RANDOM PATTERN	T1	E1
QRSS/PRBS	$2^{20} - 1$	$2^{15} - 1$

8.2 T1 Long Haul Line Build Out (LBO)

The long haul transmitter output pulses are generated using a 7-Bit internal DAC (6-Bits plus the MSB sign bit). The line build out can be set to -7.5dB, -15dB, or -22dB cable attenuation by programming the appropriate channel register. The long haul LBO consist of 32 discrete time segments extending over four consecutive periods of TCLK. As the LBO attenuation is increased, the pulse amplitude is reduced so that the waveform complies with ANSI T1.403 specifications. A long haul pulse with -7.5dB attenuation is shown in **Figure 52**, a pulse with -15dB attenuation is shown in **Figure 53**, and a pulse with -22.5dB attenuation is shown in **Figure 54**.

FIGURE 52. LONG HAUL LINE BUILD OUT WITH -7.5dB ATTENUATION

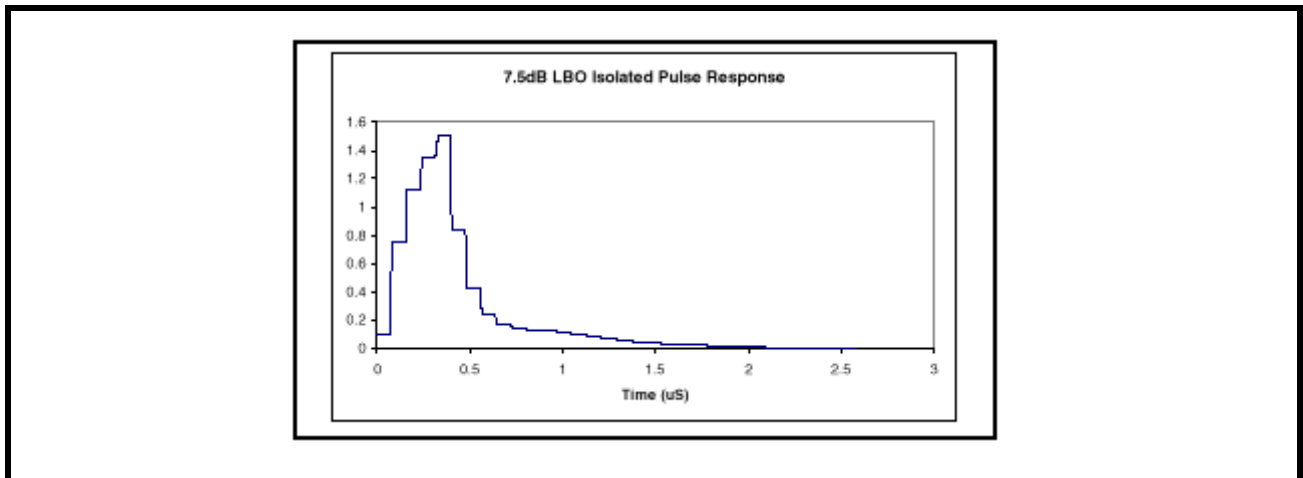

FIGURE 53. LONG HAUL LINE BUILD OUT WITH -15dB ATTENUATION

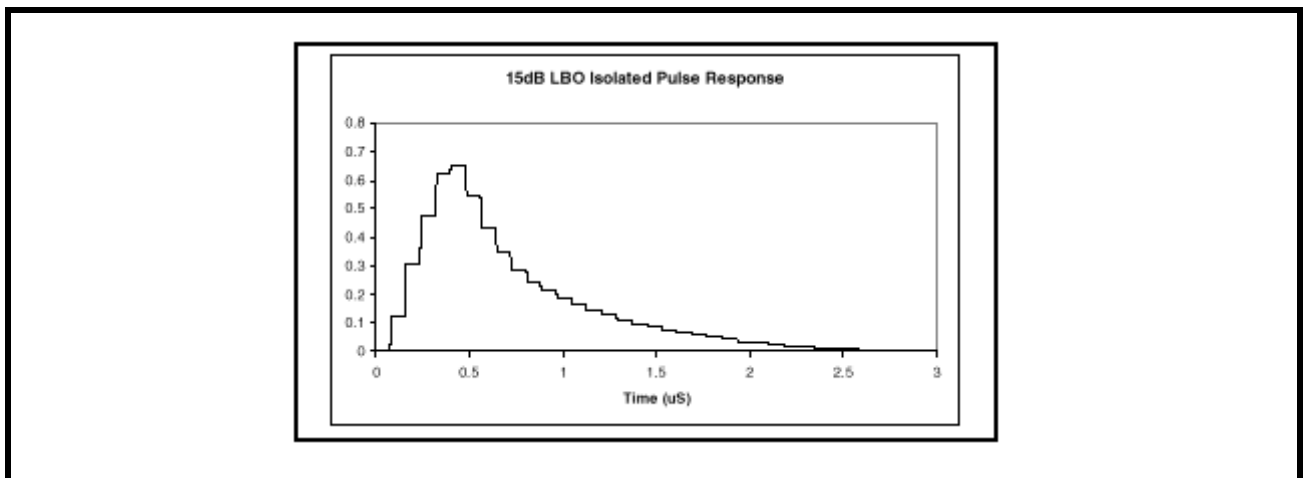
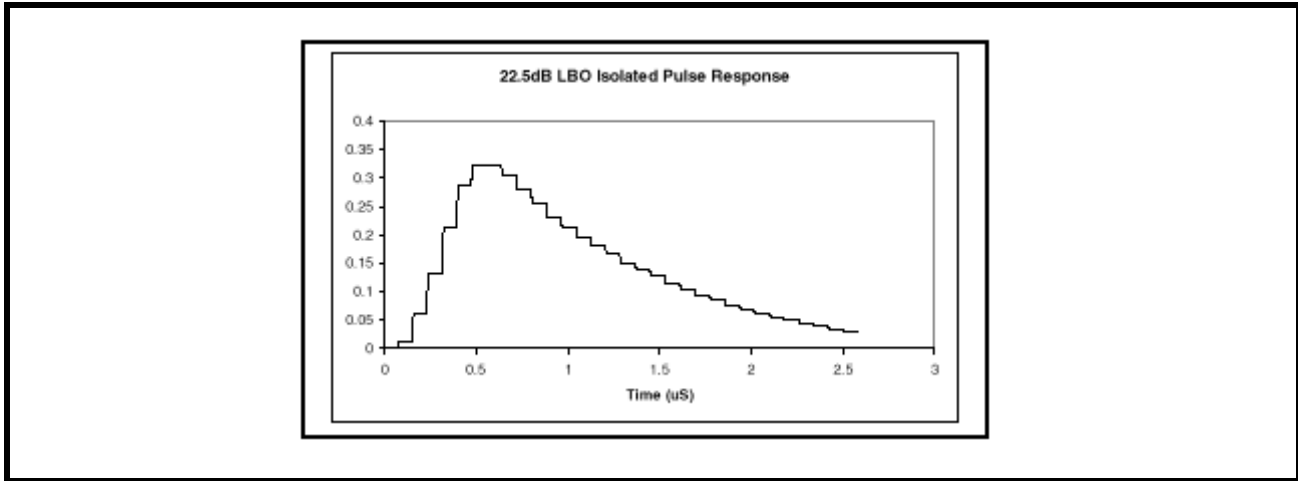

FIGURE 54. LONG HAUL LINE BUILD OUT WITH -22.5dB ATTENUATION



8.3 T1 Short Haul Line Build Out (LBO)

The short haul transmitter output pulses are generated using a 7-Bit internal DAC (6-Bit plus the MSB sign bit). The line build out can be set to interface to five different ranges of cable attenuation by programming the appropriate channel register. The pulse shape is divided into eight discrete time segments which are set to fixed values to comply with the pulse template. To program the eight segments individually to optimize a special line build out, see the arbitrary pulse section of this datasheet. The short haul LBO settings are shown in [Table 171](#)

TABLE 171: SHORT HAUL LINE BUILD OUT

LBO SETTING EQC[4:0]	RANGE OF CABLE ATTENUATION
08h (01000)	0 - 133 Feet
09h (01001)	133 - 266 Feet
0Ah (01010)	266 - 399 Feet
0Bh (01011)	399 - 533 Feet
0Ch (01100)	533 - 655 Feet

8.3.1 Arbitrary Pulse Generator

In T1 mode only, the arbitrary pulse generator divides the pulse into eight individual segments. Each segment is set by a 7-Bit binary word by programming the appropriate channel register. This allows the system designer to set the overshoot, amplitude, and undershoot for a unique line build out. The MSB (bit 7) is a sign-bit. If the sign-bit is set to "0", the segment will move in a positive direction relative to a flat line (zero) condition. If this sign-bit is set to "1", the segment will move in a negative direction relative to a flat line condition. The resolution of the DAC is typically 60mV per LSB. Thus, writing 7-bit = 1111111 will clamp the output at either voltage rail corresponding to a maximum amplitude. A pulse with numbered segments is shown in [Figure 55](#).

FIGURE 55. ARBITRARY PULSE SEGMENT ASSIGNMENT

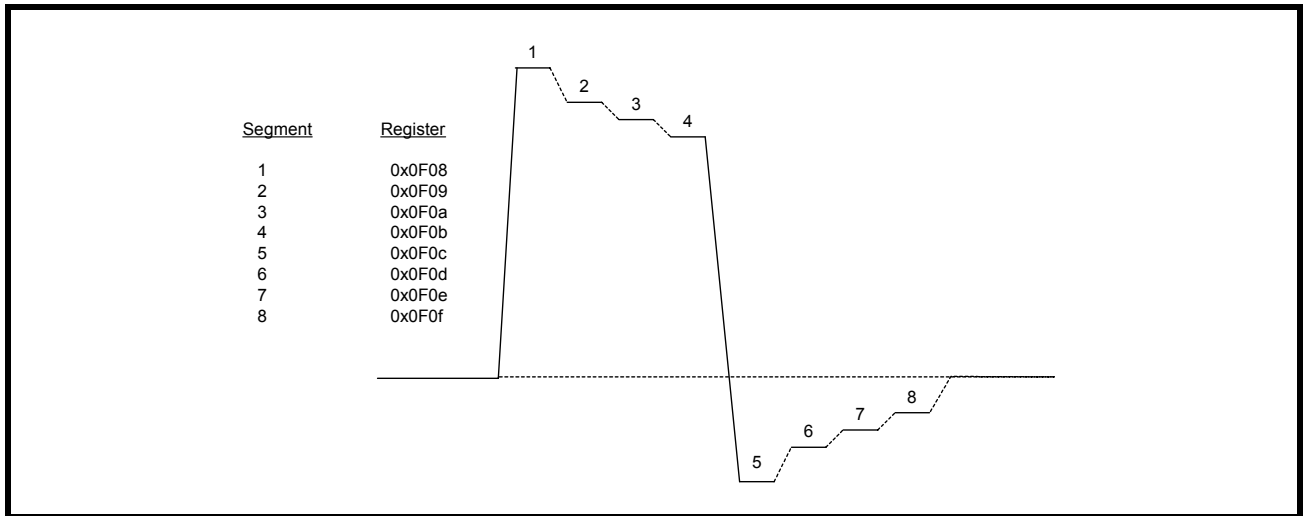

NOTE: By default, the arbitrary segments are programmed to 0x00h. The transmitter outputs will result in an all zero pattern to the line interface.

8.3.2 DMO (Digital Monitor Output)

The driver monitor circuit is used to detect transmit driver failures by monitoring the activities at TTIP/TRING outputs. Driver failure may be caused by a short circuit in the primary transformer or system problems at the transmit inputs. If the transmitter of a channel has no output for more than 128 clock cycles, DMO goes "High" until a valid transmit pulse is detected. If the DMO interrupt is enabled, the change in status of DMO will cause the interrupt pin to go "Low". Once the status register is read, the interrupt pin will return "High" and the status register will be reset (RUR).

8.3.3 Transmit Jitter Attenuator

The transmit path has a dedicated jitter attenuator to reduce phase and frequency jitter in the transmit clock. The jitter attenuator uses a data FIFO (First In First Out) with a programmable depth of 32-bit or 64-bit. When the Read and Write pointers of the FIFO are within 2-Bits of over-flowing or under-flowing, the bandwidth of the jitter attenuator is widened to track the short term input jitter, thereby avoiding data corruption. When this condition occurs, the jitter attenuator will not attenuate input jitter until the Read/Write pointer's position is outside the 2-Bit window. In T1 mode, the bandwidth of the JA is always set to 3Hz. In E1 mode, the bandwidth is programmable to either 10Hz or 1.5Hz (1.5Hz automatically selects the 64-Bit FIFO depth). The JA has a clock delay equal to 1/2 of the FIFO bit depth.

NOTE: The Receive Path has a dedicated jitter attenuator. See the Receive Path Line Interface Section.

8.4 Line Termination (TTIP/TRING)

The output stage of the transmit path generates standard return-to-zero (RZ) signals to the line interface for T1/E1/J1 twisted pair or E1 coaxial cable. The physical interface is optimized by placing the terminating impedance inside the LIU. This allows one bill of materials for all modes of operation reducing the number of external components necessary in system design. The transmitter outputs only require one DC blocking capacitor of 0.68 μ F. For redundancy applications (or simply to tri-state the transmitters), set TxTSEL to a "1" in the appropriate channel register. A typical transmit interface is shown in **Figure 56**.

FIGURE 56. TYPICAL CONNECTION DIAGRAM USING INTERNAL TERMININATION

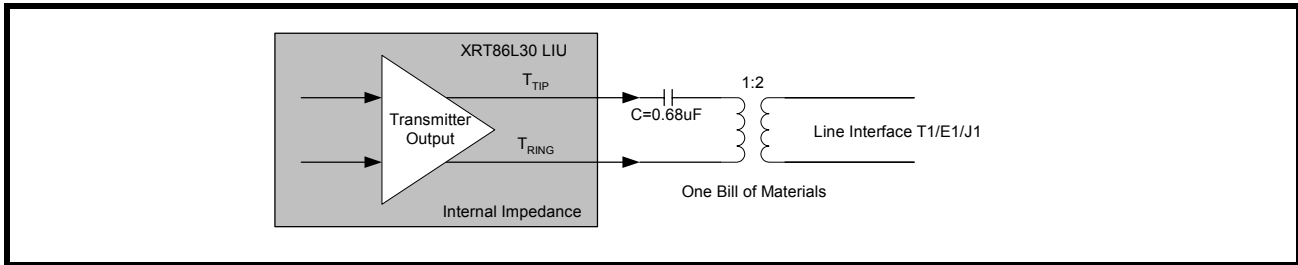

9.0 LIU RECEIVE PATH

9.1 Line Termination (RTIP/RRING)

9.1.1 CASE 1: Internal Termination

The input stage of the receive path accepts standard T1/E1/J1 twisted pair or E1 coaxial cable inputs through RTIP and RRING. The physical interface is optimized by placing the terminating impedance inside the LIU. This allows one bill of materials for all modes of operation reducing the number of external components necessary in system design. The receive termination impedance is selected by programming TERSEL[1:0] to match the line impedance. Selecting the internal impedance is shown in **Table 172**.

TABLE 172: SELECTING THE INTERNAL IMPEDANCE

TERSEL[1:0]	RECEIVE TERMINATION
0h (00)	100Ω
1h (01)	110Ω
2h (10)	75Ω
3h (11)	120Ω

The XRT86L30 has the ability to switch the internal termination to "High" impedance by programming RxTSEL in the appropriate channel register, if the RxTSEL hardware pin is "High". For internal termination, set RxTSEL to "1". By default, RxTSEL is set to "0" ("High" impedance). For redundancy applications, a dedicated hardware pin (RxTSEL) is available to control the receive termination for all channels simultaneously. This hardware pin is AND-ed with the register bit. Both, the register bit and the hardware pin must be set active for the receiver to be configured for internal impedance. **Figure 57** shows a typical connection diagram using the internal termination.

FIGURE 57. TYPICAL CONNECTION DIAGRAM USING INTERNAL TERMINATION

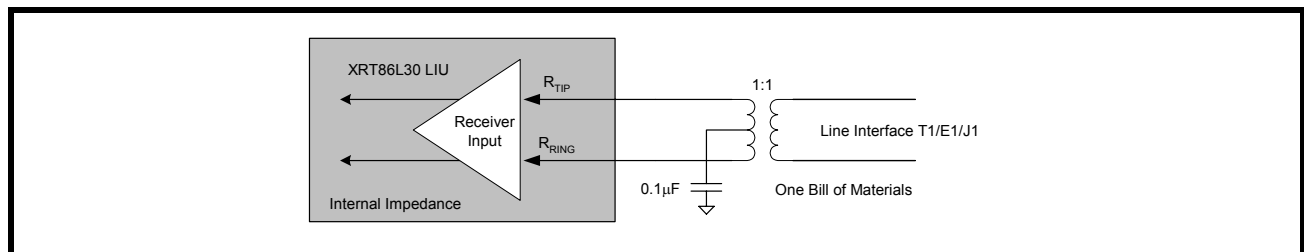

9.1.2 CASE 2: Internal Termination With One External Fixed Resistor for All Modes

Along with the internal termination, a high precision external fixed resistor can be used to optimize the return loss. This external resistor can be used for all modes of operation ensuring one bill of materials. There are three resistor values that can be used by setting the RxRES[1:0] bits in the appropriate channel register. Selecting the value for the external fixed resistor is shown in **Table 173**.

TABLE 173: SELECTING THE VALUE OF THE EXTERNAL FIXED RESISTOR

RxRES[1:0]	EXTERNAL FIXED RESISTOR
0h (00)	None
1h (01)	240Ω
2h (10)	210Ω
3h (11)	150Ω

By default, RxRES[1:0] is set to "None" for no external fixed resistor. If an external fixed resistor is used, the XRT86L30 uses the parallel combination of the external fixed resistor and the internal termination as the input impedance. See **Figure 58** for a typical connection diagram using the external fixed resistor.

NOTE: Without the external resistor, the XRT86L30 meets all return loss specifications. This mode was created to add flexibility for optimizing return loss by using a high precision external resistor.

FIGURE 58. TYPICAL CONNECTION DIAGRAM USING ONE EXTERNAL FIXED RESISTOR

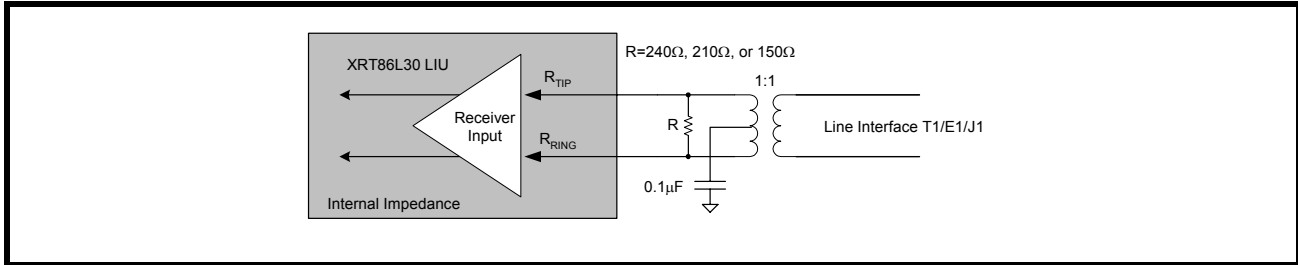

9.1.3 Equalizer Control

The main objective of the equalizer is to amplify an input attenuated signal to a pre-determined amplitude that is acceptable to the peak detector circuit. Using feedback from the peak detector, the equalizer will gain the input up to the maximum value specified by the equalizer control bits, in the appropriate channel register, normalizing the signal. Once the signal has reached the pre-determined amplitude, the signal is then processed within the peak detector and slicer circuit. A simplified block diagram of the equalizer and peak detector is shown in **Figure 59**.

FIGURE 59. SIMPLIFIED BLOCK DIAGRAM OF THE EQUALIZER AND PEAK DETECTOR

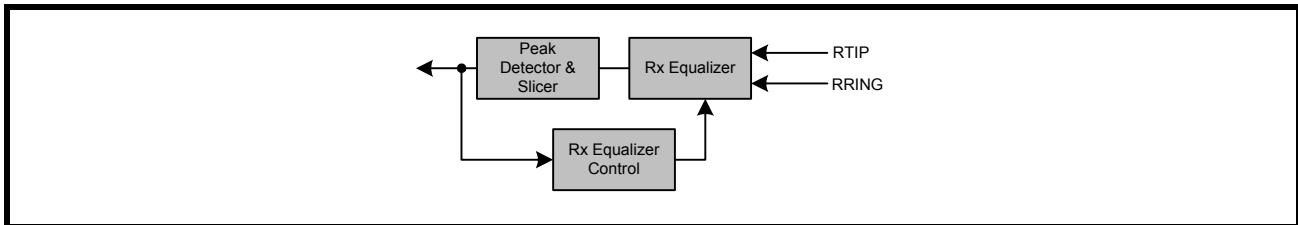

9.1.4 Cable Loss Indicator

The ability to monitor the cable loss attenuation of the receiver inputs is a valuable feature. The XRT86L30 contains a per channel, read only register for cable loss indication. CLOS[5:0] is a 6-Bit binary word that reports the value of cable loss in 1dB steps with an absolute accuracy of ±1dB. An example of -25dB cable loss attenuation is shown in **Figure 60**.

FIGURE 60. SIMPLIFIED BLOCK DIAGRAM OF THE CABLE LOSS INDICATOR

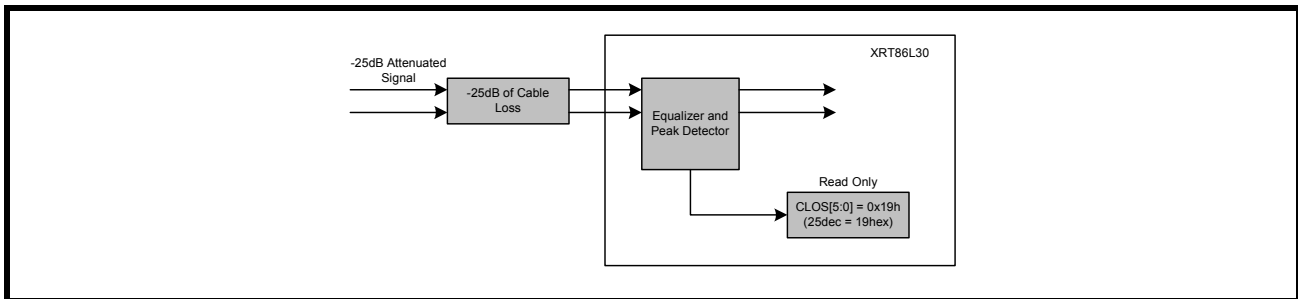

9.2 Receive Sensitivity

To meet Long Haul receive sensitivity requirements, the XRT86L30 can accept T1/E1/J1 signals that have been attenuated by 43dB cable attenuation in E1 mode or 36dB cable attenuation in T1 mode without experiencing bit errors, LOF, pattern synchronization, etc. Short haul specifications are for 12dB of flat loss in E1 mode. T1 specifications are 655 feet of cable loss along with 6dB of flat loss in T1 mode. The XRT86L30 can tolerate cable loss and flat loss beyond the industry specifications. The receive sensitivity in the short haul mode is approximately 4,000 feet without experiencing bit errors, LOF, pattern synchronization, etc. Although data integrity is maintained, the RLOS function (if enabled) will report an RLOS condition according to the receiver loss of signal section in this datasheet. The test configuration for measuring the receive sensitivity is shown in **Figure 61**.

FIGURE 61. TEST CONFIGURATION FOR MEASURING RECEIVE SENSITIVITY

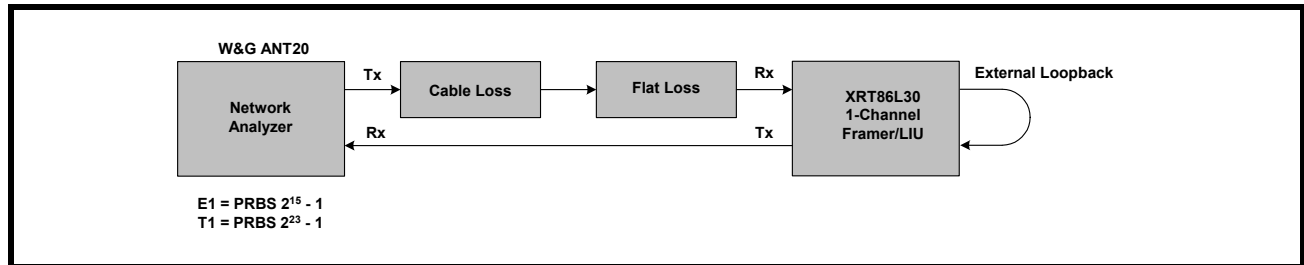

9.2.1 AIS (Alarm Indication Signal)

The XRT86L30 adheres to the ITU-T G.775 specification for an all ones pattern. The alarm indication signal is set to "1" if an all ones pattern (at least 99.9% ones density) is present for T, where T is 3ms to 75ms in T1 mode. AIS will clear when the ones density is not met within the same time period T. In E1 mode, the AIS is set to "1" if the incoming signal has 2 or less zeros in a 512-bit window. AIS will clear when the incoming signal has 3 or more zeros in the 512-bit window.

9.2.2 NLCD (Network Loop Code Detection)

The Network Loop Code Detection can be programmed to detect a Loop-Up, Loop-Down, or Automatic Loop Code. If the network loop code detection is programmed for Loop-Up, the NLCD will be set "High" if a repeating pattern of "00001" occurs for more than 5 seconds. If the network loop code detection is programmed for Loop-Down, the NLCD will be set "High" if a repeating pattern of "001" occurs for more than 5 seconds. If the network loop code detection is programmed for automatic loop code, the LIU is configured to detect a Loop-Up code. If a Loop-Up code is detected for more than 5 seconds, the XRT86L30 will automatically program the channel into a remote loopback mode. The LIU will remain in remote loopback even if the Loop-Up code disappears. The channel will continue in remote loop back until a Loop-Down code is detected for more than 5 seconds (or, if the automatic loop code is disabled) and then automatically return to normal operation with no loop back. The process of the automatic loop code detection is shown in **Figure 62**.

FIGURE 62. PROCESS BLOCK FOR AUTOMATIC LOOP CODE DETECTION

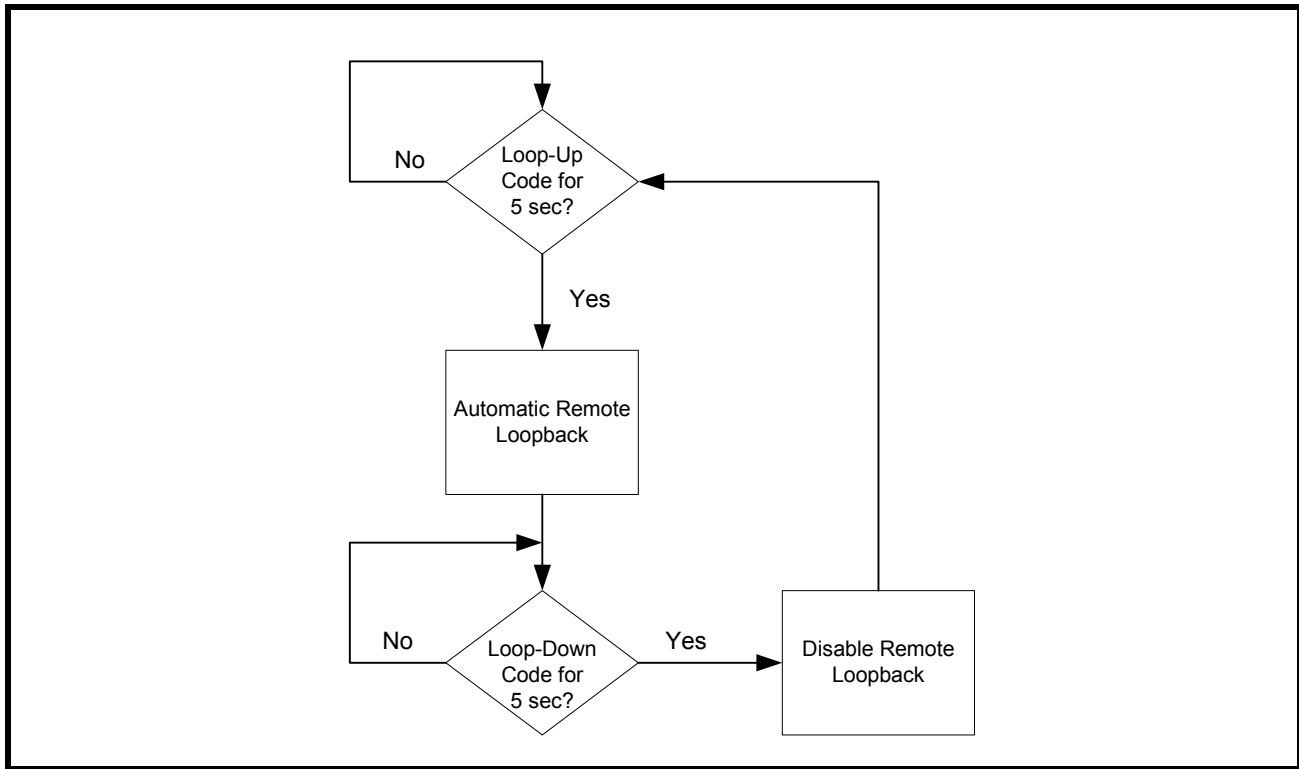

9.2.3 FLSD (FIFO Limit Status Detection)

The purpose of the FIFO limit status is to indicate when the Read and Write FIFO pointers are within a pre-determined range (over-flow or under-flow indication). The FLSD is set to "1" if the FIFO Read and Write Pointers are within ± 3 -Bits.

9.2.4 Receive Jitter Attenuator

The receive path has a dedicated jitter attenuator to reduce phase and frequency jitter in the recovered clock. The jitter attenuator uses a data FIFO (First In First Out) with a programmable depth of 32-bit or 64-bit. If the LIU is used for line synchronization (loop timing systems), the JA should be enabled in the receive path. When the Read and Write pointers of the FIFO are within 2-Bits of over-flowing or under-flowing, the bandwidth of the jitter attenuator is widened to track the short term input jitter, thereby avoiding data corruption. When this condition occurs, the jitter attenuator will not attenuate input jitter until the Read/Write pointer's position is outside the 2-Bit window. In T1 mode, the bandwidth of the JA is always set to 3Hz. In E1 mode, the bandwidth is programmable to either 10Hz or 1.5Hz (1.5Hz automatically selects the 64-Bit FIFO depth). The JA has a clock delay equal to $\frac{1}{2}$ of the FIFO bit depth.

NOTE: The Transmit Path has a dedicated jitter attenuator. See the Transmit Path Line Interface Section.

9.2.5 RxMUTE (Receiver LOS with Data Muting)

The receive muting function can be selected by setting RxMUTE to "1" in the appropriate global register. If selected, any channel that experiences an RLOS condition will automatically pull the output of the LIU section "Low" to prevent data chattering. If RLOS does not occur, the RxMUTE will remain inactive until an RLOS on a given channel occurs. The default setting for RxMUTE is "0" which is disabled. A simplified block diagram of the RxMUTE function is shown in [Figure 63](#).

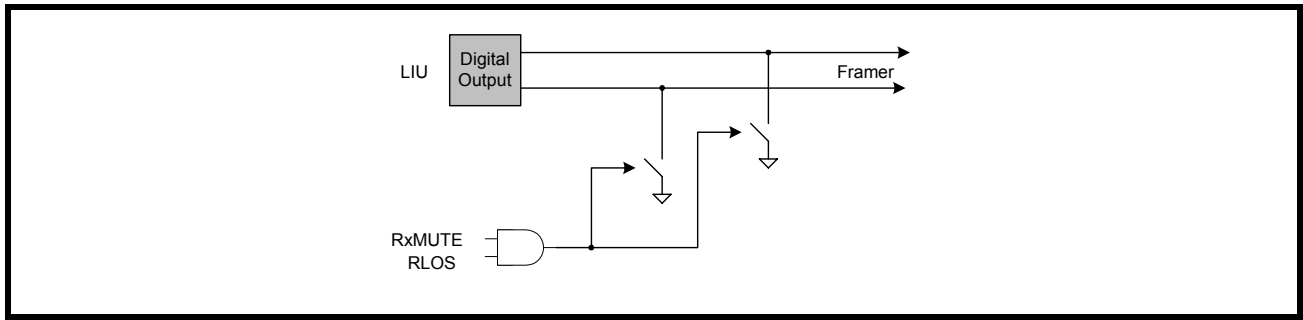
FIGURE 63. SIMPLIFIED BLOCK DIAGRAM OF THE RxMUTE FUNCTION

10.0 THE E1 TRANSMIT/RECEIVE FRAMER

10.1 Description of the Transmit/Receive Payload Data Input Interface Block

Each of the four framers within the XRT86L30 device includes a Transmit and Receive Payload Data Input Interface block. Although most configurations are independent for the Tx and Rx path, once E1 framing has been selected, both the Tx and Rx must operate in E1. The Payload Data Input Interface module (also known as the Back-plane Interface module) supports payload data to be taken from or presented to the system. In E1 mode, supported data rates are 2.048Mbit/s, MVIP 2.048Mbit/s, 4.096Mbit/s, 8.192Mbit/s, multiplexed 16.384Mbit/s, HMVIP 16.384Mbit/s, or H.100 16.384Mbit/s.

10.1.1 Brief Discussion of the Transmit/Receive Payload Data Input Interface Block Operating at XRT84V24 Compatible 2.048Mbit/s mode

Whether or not the transmit/receive interface signals have been chosen as inputs or outputs, the overall system timing diagrams remain the same. It is the responsibility of the Terminal Equipment to provide serial input data through the TxSER pin aligned with the Transmit Single-frame Synchronization signal and the Transmit Multi-frame Synchronization signal. **Figure 64** shows how to connect the Transmit Payload Data Input Interface block to local Terminal Equipment. **Figure 65** shows how to connect the Receive Payload Data Output Interface to local Terminal Equipment.

FIGURE 64. INTERFACING THE TRANSMIT PATH TO LOCAL TERMINAL EQUIPMENT

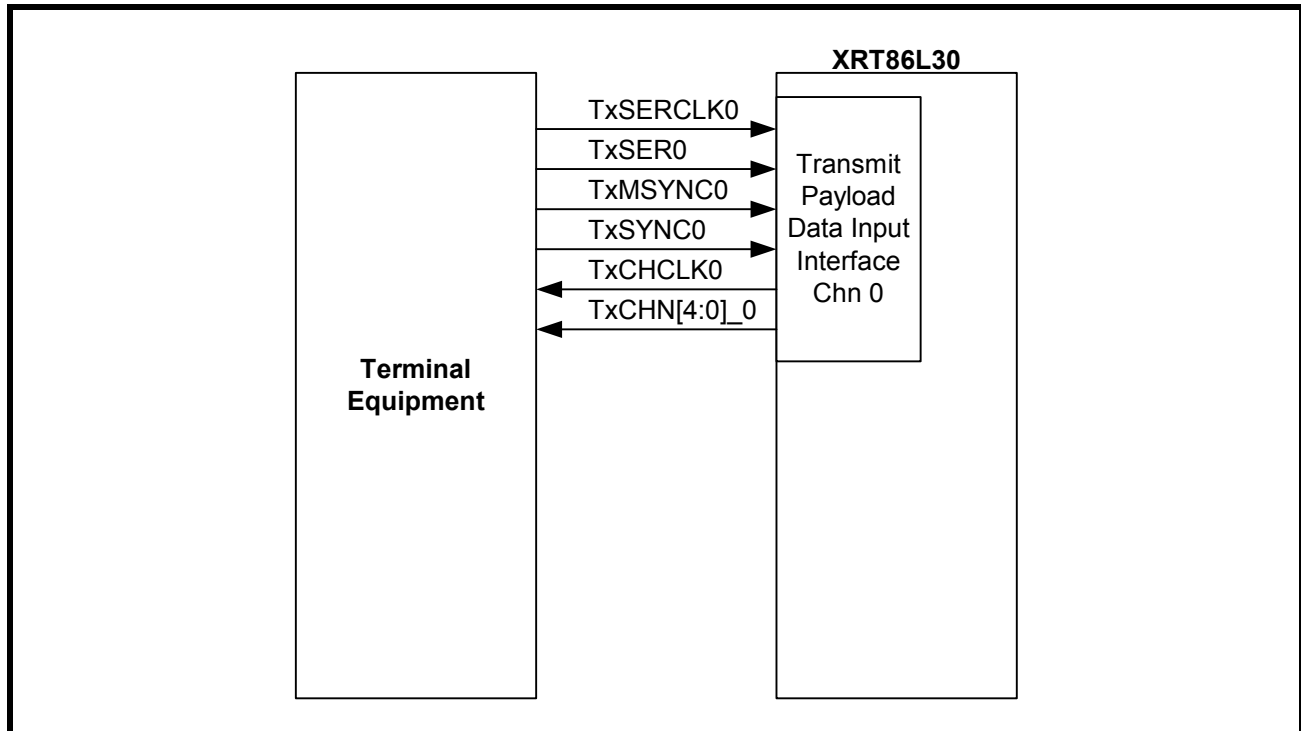

FIGURE 65. INTERFACING THE RECEIVE PATH TO LOCAL TERMINAL EQUIPMENT

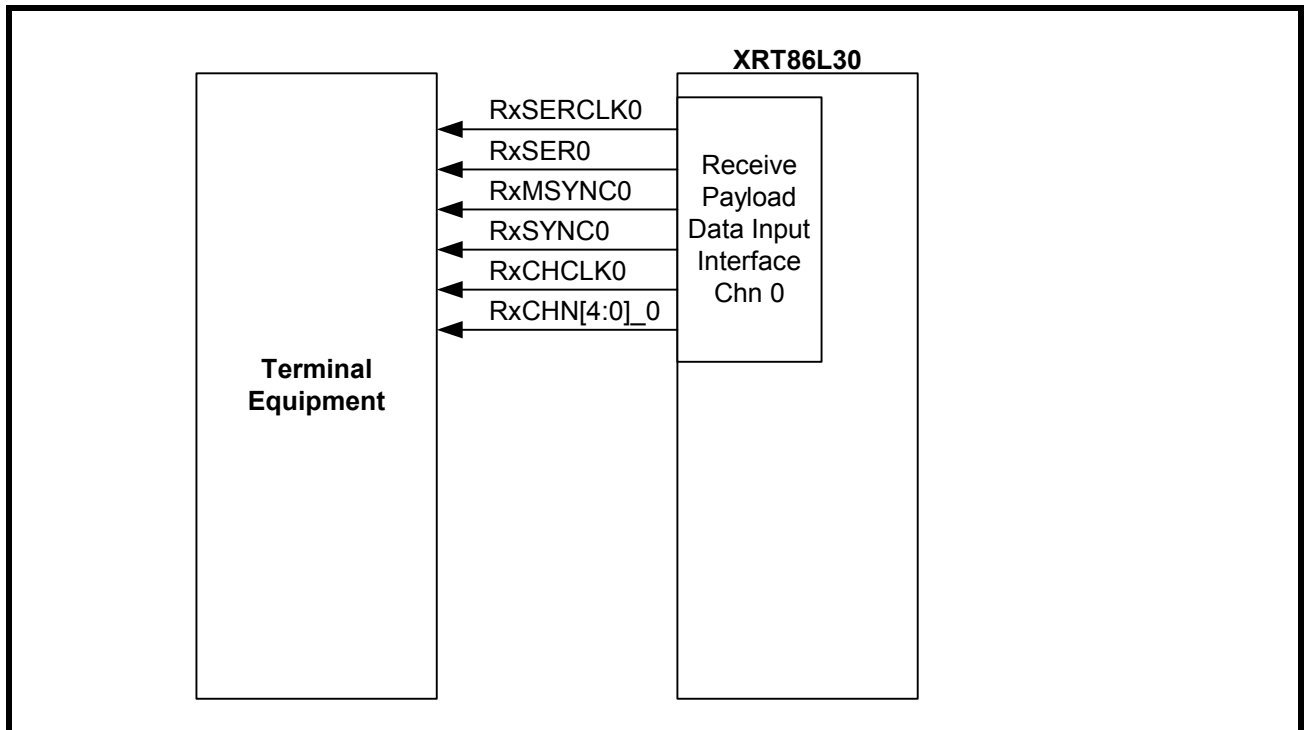

Figure 66 shows the waveforms for connecting the Transmit Payload Data Input Interface block to local Terminal Equipment. Figure 67 shows the waveforms for connecting the Receive Payload Data Input Interface block to local Terminal Equipment.

FIGURE 66. WAVEFORMS FOR CONNECTING THE TRANSMIT PAYLOAD DATA INPUT INTERFACE BLOCK TO LOCAL TERMINAL EQUIPMENT

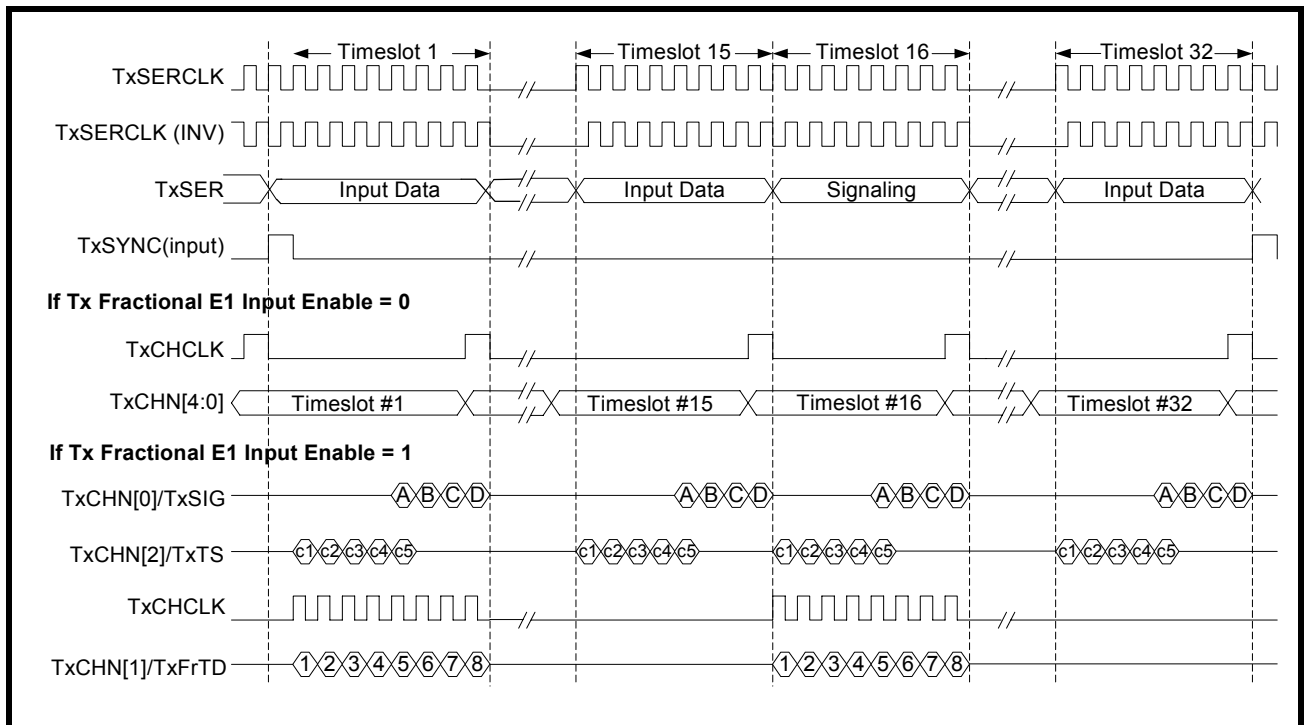
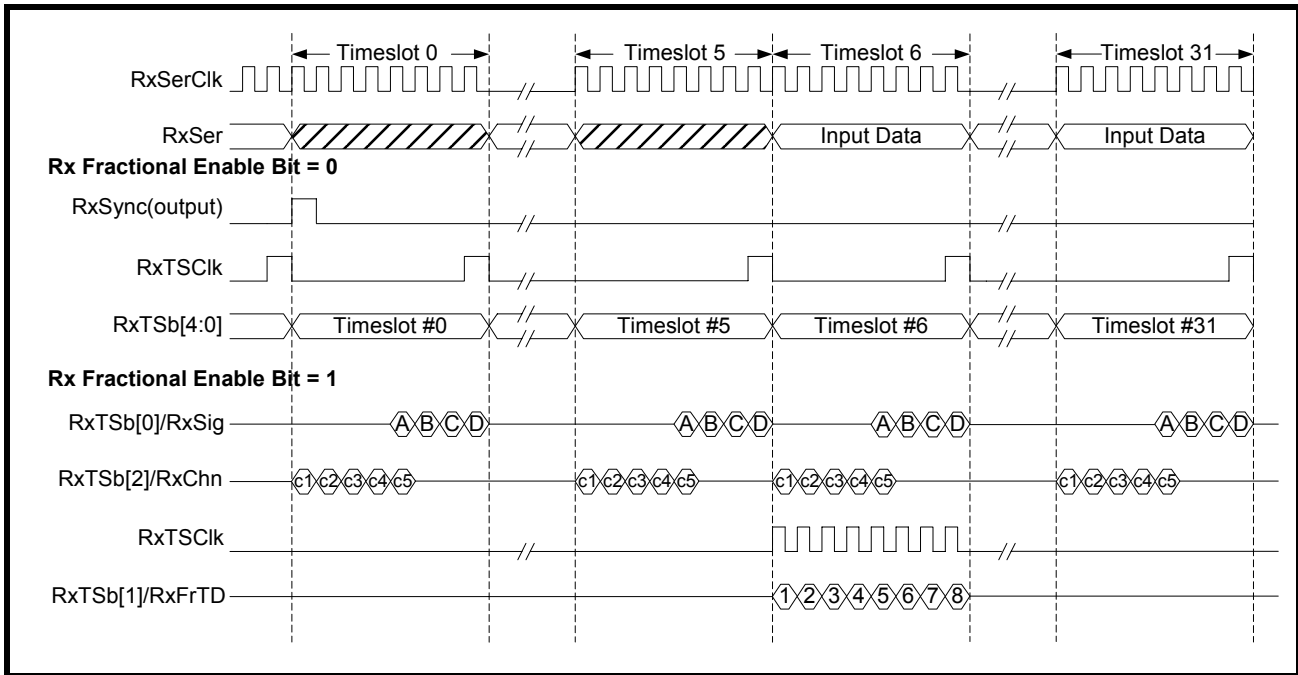

FIGURE 67. WAVEFORMS FOR CONNECTING THE RECEIVE PAYLOAD DATA INPUT INTERFACE BLOCK TO LOCAL TERMINAL EQUIPMENT



10.2 Transmit/Receive High-Speed Back-Plane Interface

The High-speed Back-plane Interface supports payload data to be taken from or presented to the Terminal Equipment at different data rates. In the non-multiplexed mode, payload data of each channel are interfaced to the Terminal Equipment separately. Each channel uses its own serial clock, serial data, single-frame synchronization signal and multi-frame synchronization signals.

10.2.1 Non-Multiplexed High-Speed Mode

When the Back-plane interface data rate is MVIP 2.048Mbit/s, 4.096Mbit/s and 8.192Mbit/s, the interface signals are all configured as inputs, except the receive serial data on RxSER and the multi frame sync pulse provided by the framer. The Transmit Serial Clock for each channel is always an input clock with frequency of 2.048 MHz for all data rates so that it may be used as the timing reference for the transmit line rate. The TxMSYNC signal is configured as the Transmit Input Clock with frequencies of 2.048 MHz, 4.096 MHz and 8.192 MHz respectively. It serves as the primary clock source for the High-speed Back-plane Interface. **Figure 68** shows how to connect the Transmit non-multiplexed high-speed Input Interface block to local Terminal Equipment. **Figure 69** shows how to connect the Receive non-multiplexed high-speed Output Interface to local Terminal Equipment.

FIGURE 68. TRANSMIT NON-MULTIPLEXED HIGH-SPEED CONNECTION TO LOCAL TERMINAL EQUIPMENT USING MVIP 2.048MBIT/S, 4.096MBIT/S, OR 8.192MBIT/S

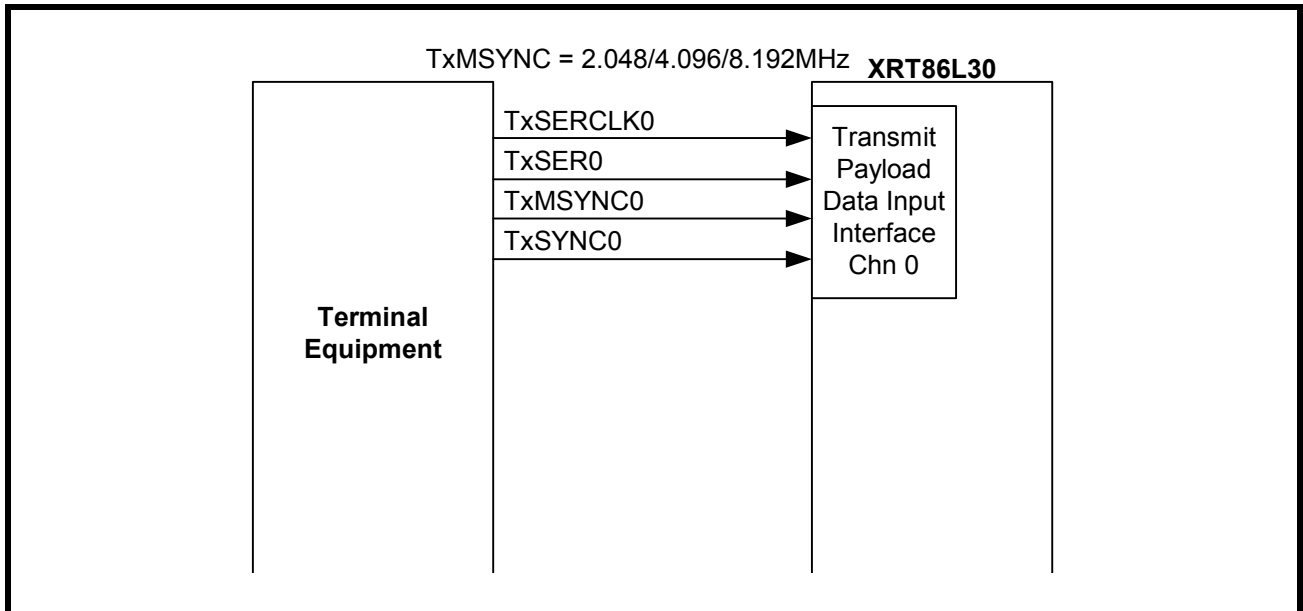

FIGURE 69. RECEIVE NON-MULTIPLEXED HIGH-SPEED CONNECTION TO LOCAL TERMINAL EQUIPMENT USING MVIP 2.048MBIT/S, 4.096MBIT/S, OR 8.192MBIT/S

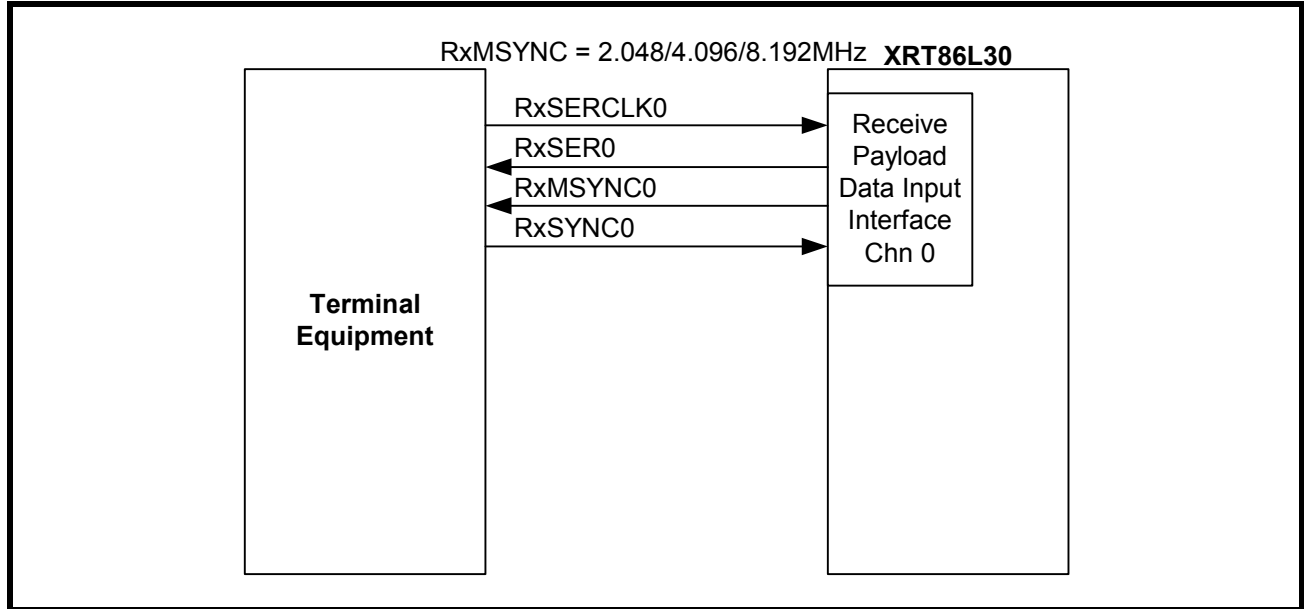

Figure 70 shows the waveforms for connecting the Transmit non-multiplexed high-speed Input Interface block to local Terminal Equipment. Figure 71 shows the waveforms for connecting the Receive non-multiplexed high-speed Input Interface block to local Terminal Equipment.

FIGURE 70. WAVEFORMS FOR CONNECTING THE TRANSMIT NON-MULTIPLEXED HIGH-SPEED INPUT INTERFACE AT MVIP 2.048MBIT/S, 4.096MBIT/S, AND 8.192MBIT/S

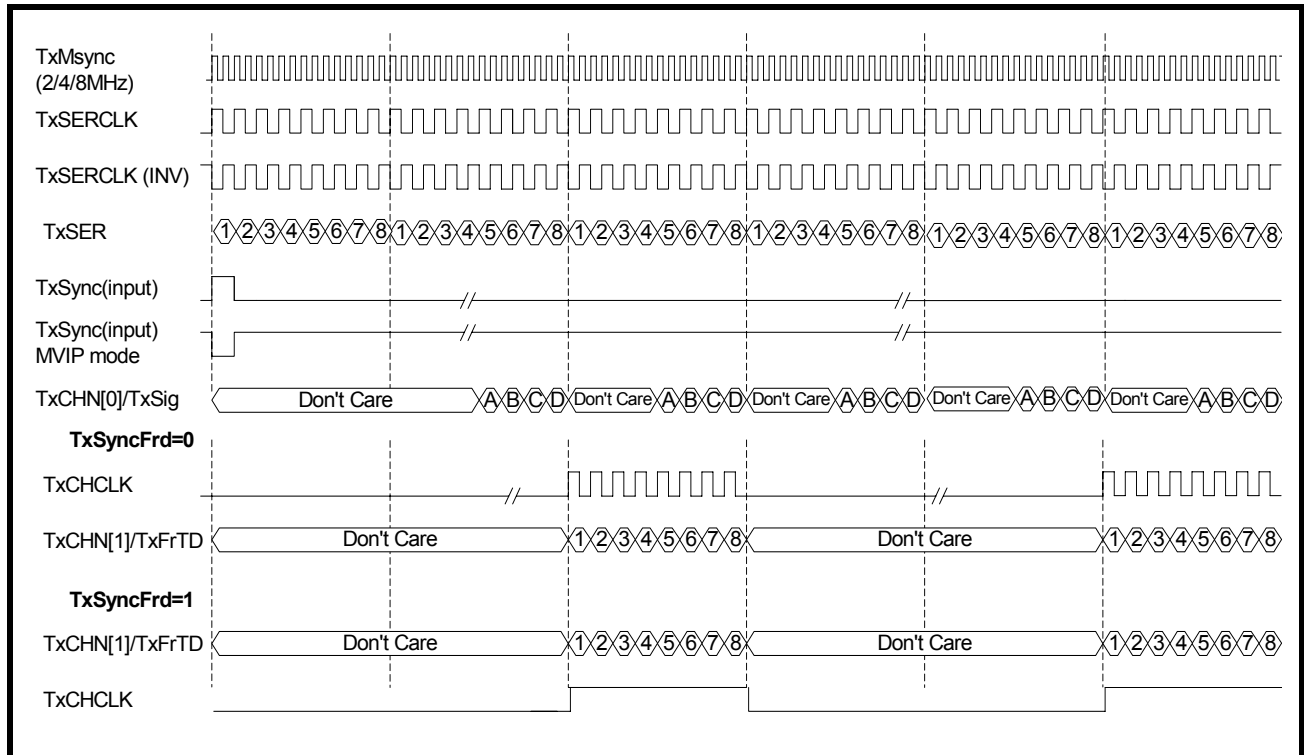
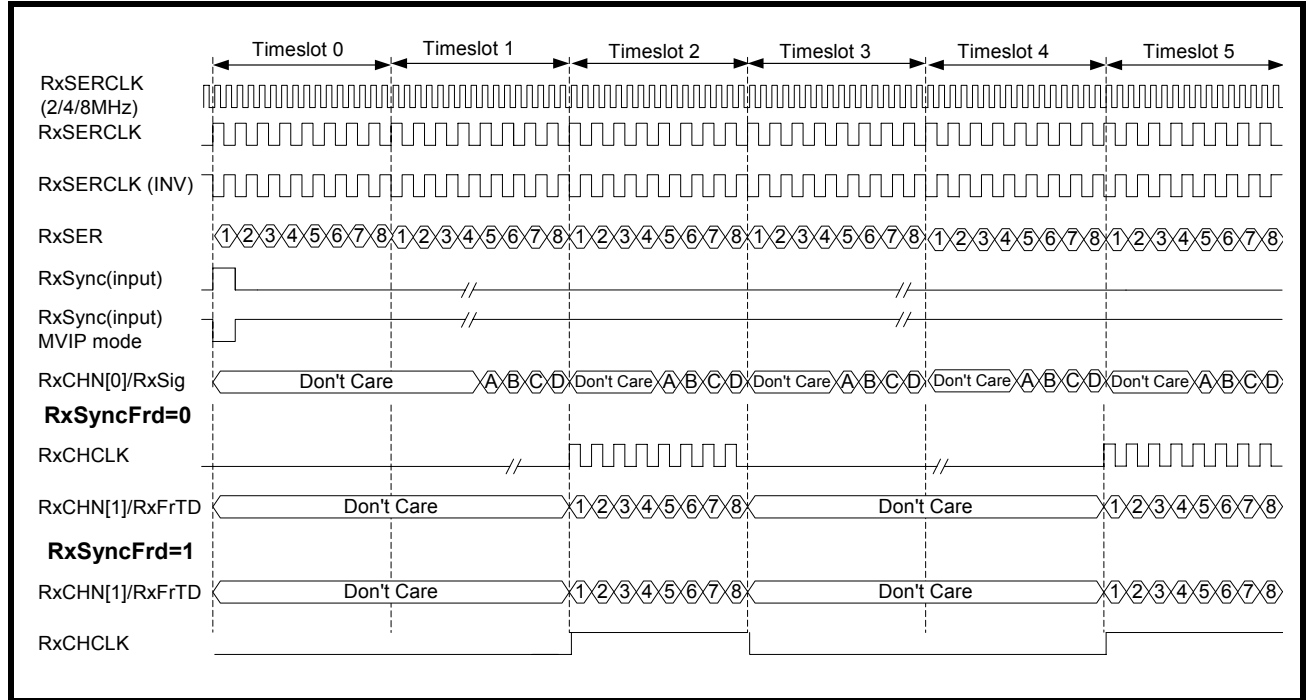

FIGURE 71. WAVEFORMS FOR CONNECTING THE RECEIVE NON-MULTIPLIED HIGH-SPEED INPUT INTERFACE AT MVIP 2.048MBIT/S, 4.096MBIT/S, AND 8.192MBIT/S



10.2.2 Multiplexed High-Speed Mode

When the Back-plane interface data rate is 16.384Mbit/s, HMVIP 16.384Mbit/s, and H.100 16.384Mbit/s, the interface signals are all configured as inputs, except the receive serial data on RxSER and the multi frame sync pulse provided by the framer. The Transmit Serial Clock for each channel is always an input clock with frequency of 2.048 MHz for all data rates so that it may be used as the timing reference for the transmit line rate. The TxMSYNC signal is configured as the Transmit Input Clock with frequency of 16.384 MHz. It serves as the primary clock source for the High-speed Back-plane Interface. Payload and signaling data of Channel 0-3 are multiplexed onto the Transmit Serial Data pin of Channel 0. Payload and signaling data of Channel 4-7 are multiplexed onto the Transmit Serial Data pin of Channel 4. The Transmit Single-frame Synchronization signal of Channel 0 pulses HIGH at the beginning of the multiplexed frame with data from Channel 0-3 multiplexed together. The Transmit Single-frame Synchronization signal of Channel 4 pulses HIGH at the beginning of the multiplexed frame with data from Channel 4-7 multiplexed together. It is the responsibility of the Terminal Equipment to align the multiplexed transmit serial data with the Transmit Single-frame Synchronization pulse. Additionally, each channel requires the local Terminal Equipment to provide a free-running 2.048 MHz clock into the Transmit Serial Clock input. The local Terminal Equipment maps four 2.048Mbit/s E1 data streams into one 16.384Mbit/s serial data stream as described below:

1. Payload data of four channels are repeated and grouped together in a bit-interleaved way. The first payload bit of Timeslot 0 of Channel 0 is sent first, followed by the first payload bit of Timeslot 0 of Channel 1 and 2. The first payload bit of Timeslot 0 of Channel 3 is sent last.

After the first bit of Timeslot 0 of all four channels are sent, it comes the second bit of Timeslot 0 of Channel 0 and so on. The table below demonstrates how payload bits of four channels are mapped into the 16.384Mbit/s data stream.

FIRST OCTET OF 16.384MBIT/S DATA STREAM

BIT 0	BIT 1	BIT 2	BIT 3	BIT 4	BIT 5	BIT 6	BIT 7
1_0	1_0	1_1	1_1	1_2	1_2	1_3	1_3

SECOND OCTET OF 16.384MBIT/S DATA STREAM

BIT 0	BIT 1	BIT 2	BIT 3	BIT 4	BIT 5	BIT 6	BIT 7
2_0	2_0	2_1	2_1	2_2	2_2	2_3	2_3

X_Y : The Xth payload bit of Channel Y

2. The local Terminal Equipment also multiplexed signaling bits with payload bits and sent them together through the 16.384Mbit/s data stream.

When the Terminal Equipment is sending the fifth payload bit of one channel, instead of sending it twice, it inserts the signaling bit A of that corresponding channel. Similarly, the sixth payload bit is followed by the signaling bit B of that corresponding channel; the seventh payload bit is followed by the signaling bit C; the eighth payload bit is followed by the signaling bit D.

The following table illustrates how payload bits and signaling bits are multiplexed together into the 16.384Mbit/s data stream.

FIFTH OCTET OF 16.384MBIT/S DATA STREAM

BIT 0	BIT 1	BIT 2	BIT 3	BIT 4	BIT 5	BIT 6	BIT 7
5_0	A_0	5_1	A_1	5_2	A_2	5_3	A_3

SIXTH OCTET OF 16.384MBIT/S DATA STREAM

BIT 0	BIT 1	BIT 2	BIT 3	BIT 4	BIT 5	BIT 6	BIT 7
6 ₀	B ₀	6 ₁	B ₁	6 ₂	B ₂	6 ₃	B ₃

SEVENTH OCTET OF 16.384MBIT/S DATA STREAM

BIT 0	BIT 1	BIT 2	BIT 3	BIT 4	BIT 5	BIT 6	BIT 7
7 ₀	C ₀	7 ₁	C ₁	7 ₂	C ₂	7 ₃	C ₃

EIGHTH OCTET OF 16.384MBIT/S DATA STREAM

BIT 0	BIT 1	BIT 2	BIT 3	BIT 4	BIT 5	BIT 6	BIT 7
8 ₀	D ₀	8 ₁	D ₁	8 ₂	D ₂	8 ₃	D ₃

X_Y: The Xth payload bit of Channel Y

A_Y: The signaling bit A of Channel Y

3. After the first octet of all four channels are sent, the local Terminal Equipment start sending the second octets following the same rules of Step 1 and 2.

The Transmit Single-frame Synchronization signal of Channel 0 pulses HIGH for one clock cycle at the first bit position of the multiplexed data stream with data from Channel 0-3 multiplexed together. The Transmit Single-frame Synchronization signal of Channel 4 pulses HIGH for one clock cycle at the first bit position of the data stream with data from Channel 4-7 multiplexed together. By sampling the HIGH pulse on the Transmit Single-frame Synchronization signal, the framer can position the beginning of the multiplexed E1 frame. It is the responsibility of the Terminal Equipment to align the multiplexed transmit serial data with the Transmit Single-frame Synchronization pulse.

Inside the framer, all the "don't care" bits will be stripped away. The framing bits, signaling and payload data are de-multiplexed inside the XRT86L30 device and send to each individual channel. These data will be processed by each individual framer and send to LIU interface. The local Terminal Equipment provides a free-running 2.048MHz clock to the Transmit Serial Input clock of each channel. The framer will use this clock to carry the processed payload and signaling data to the transmit section of the device. **Figure 72** shows how to connect the Transmit multiplexed high-speed Input Interface block to local Terminal Equipment. **Figure 73** shows how to connect the Receive multiplexed high-speed Output Interface to local Terminal Equipment.

FIGURE 72. INTERFACING XRT86L30 TRANSMIT TO LOCAL TERMINAL EQUIPMENT USING 16.384MBIT/S, HMPVIP 16.384MBIT/S, AND H.100 16.384MBIT/S

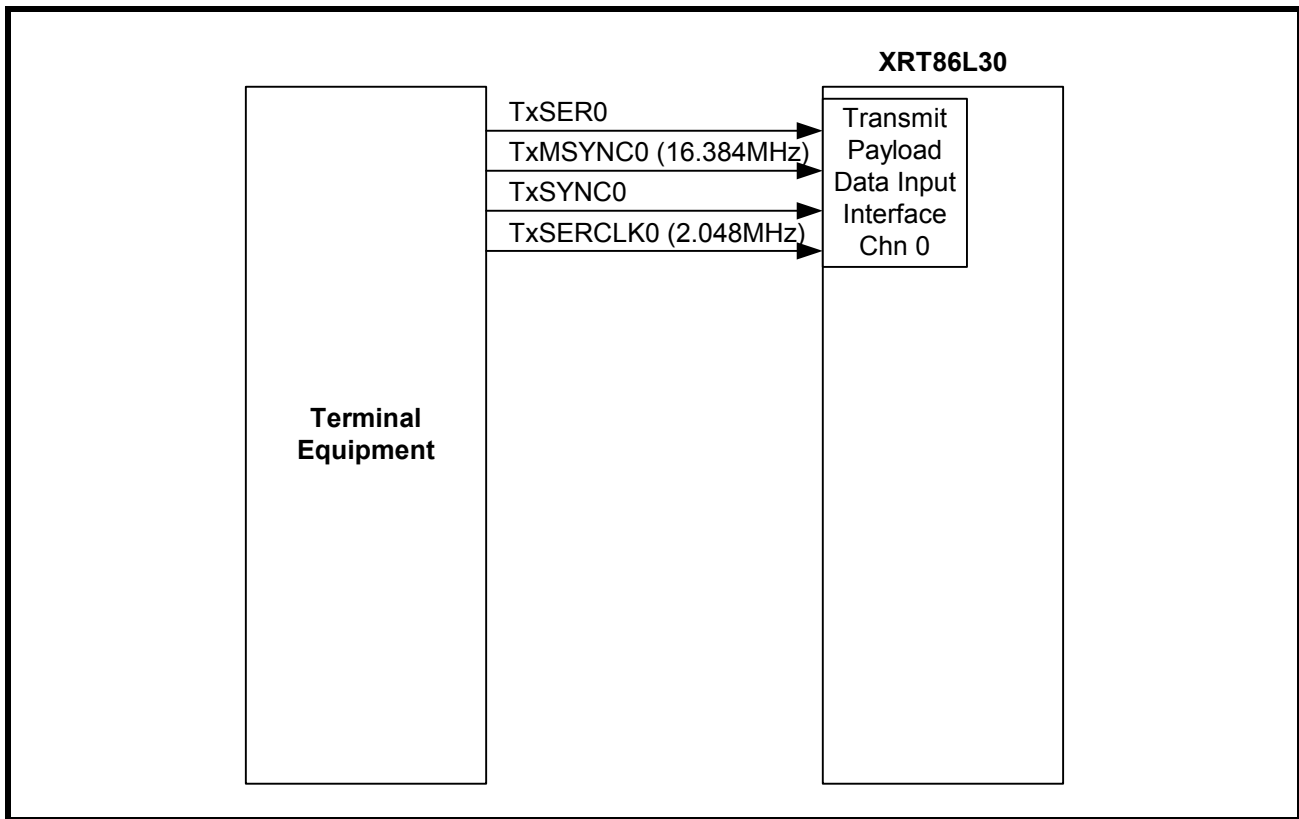

FIGURE 73. INTERFACING XRT86L30 RECEIVE TO LOCAL TERMINAL EQUIPMENT USING 16.384MBIT/S, HMVIP 16.384MBIT/S, AND H.100 16.384MBIT/S

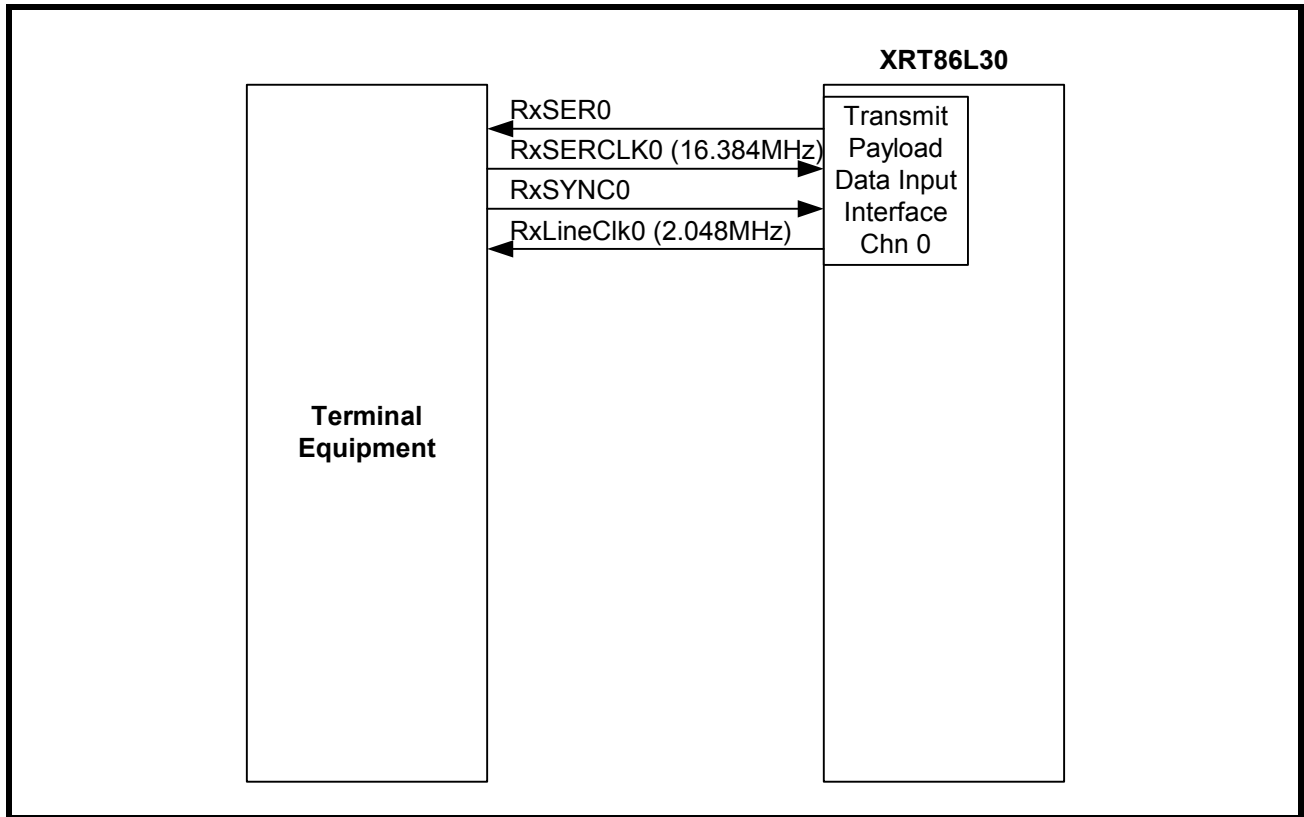

Figure 74 shows the waveforms for connecting the Transmit multiplexed high-speed Input Interface block to local Terminal Equipment. Figure 75 shows the waveforms for connecting the Receive multiplexed high-speed Input Interface block to local Terminal Equipment for HMVIP. Figure 76 shows the waveforms for

connecting the Receive multiplexed high-speed Input Interface block to local Terminal Equipment for HMVI.100P.

FIGURE 74. WAVEFORMS FOR CONNECTING THE TRANSMIT MULTIPLEXED HIGH-SPEED INPUT INTERFACE AT HMVIP AND H.100 16.384MBIT/S MODE

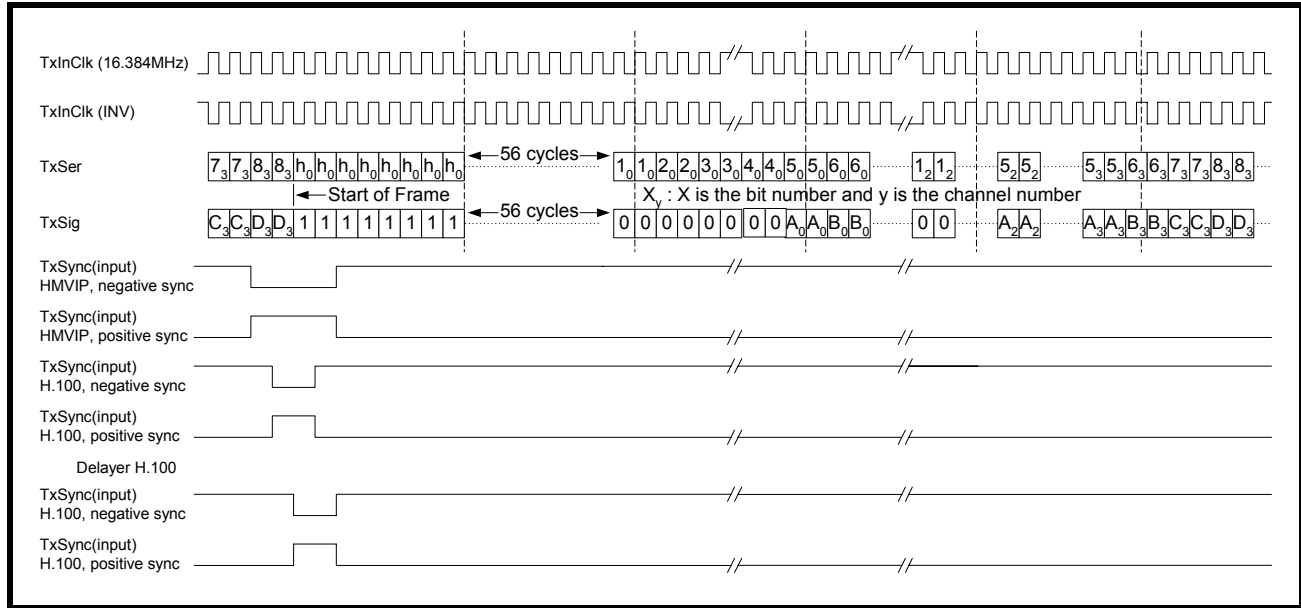

FIGURE 75. WAVEFORMS FOR CONNECTING THE RECEIVE MULTIPLEXED HIGH-SPEED INPUT INTERFACE AT HMVIP 16.384MBIT/S MODE

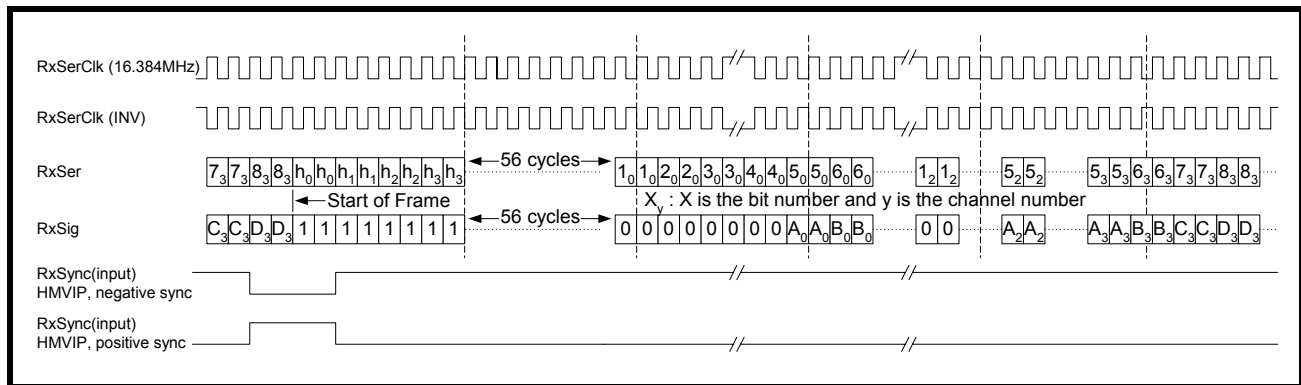
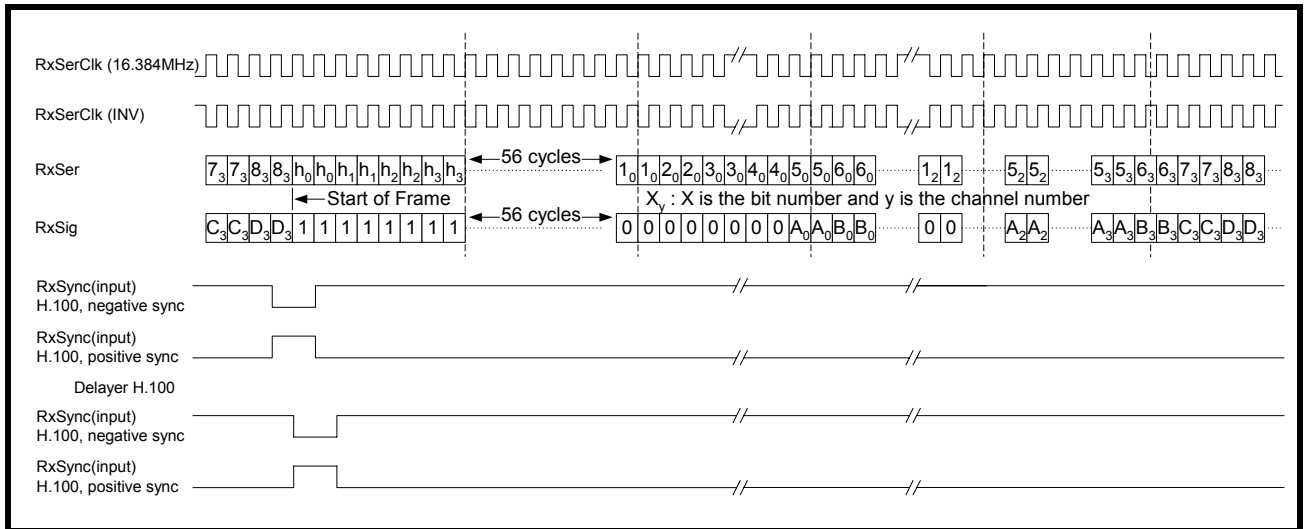

FIGURE 76. WAVEFORMS FOR CONNECTING THE RECEIVE MULTIPLEXED HIGH-SPEED INPUT INTERFACE AT H.100 16.384MBIT/S MODE



10.3 Brief Discussion of Common Channel Signaling in E1 Framing Format

As the name referred, Common Channel Signaling is signaling information common to all thirty voice or data channels of an E1 trunk. Time slot 16 may be used to carry Common Channel Signaling data of up to a rate of 64kbits/s. The national bits of time slot 0 may also be used for Common Channel Signaling. Since there are five national bits of time slot 0 per every two E1 frames, the total bandwidth of the national bits is 20kbits/s. The Common Channel Signaling is essentially data link information that provides performance monitoring and a transmission quality report.

10.4 Brief Discussion of Channel Associated Signaling in E1 Framing Format

Signaling is required when dealing with voice and dial-up data services in E1 applications. Traditionally, signaling is provided on a dial-up telephone line across the talk-path. Signaling is used to tell the receiver where the call or route is destined. The signal is sent through switches along the route to a distant end. Common types of signals are:

- On hook
- Off hook
- Dial tone
- Dialed digits
- Ringing cycle
- Busy tone

A signal consists of four bits namely A, B, C and D. These bits define the state of the call for a particular time slot. Time slot 16 of each E1 frame can carry CAS signals for two E1 voice or data channels. Therefore, sixteen E1 frames are needed to carry CAS signals for all 32 E1 channels. The sixteen E1 frames then forms a CAS Multi-frame.

10.5 Insert/Extract Signaling Bits from TSCR Register

The four most significant bits of the Transmit Signaling Control Register (TSCR) of each time slot can be used to store outgoing signaling data. The user can program these bits through microprocessor access. If the XRT86L30 framer is configured to insert signaling bits from TSCR registers, the E1 Transmit Framer block will fill up the time slot 16 octet with the signaling bits stored inside the TSCR registers. The insertion of signaling bit into PCM data is done on a per-channel basis. The most significant bit (Bit 7) of TSCR register is used to store Signaling bit A. Bit 6 is used to hold Signaling bit B. Bit 5 is used to hold Signaling bit C. Bit 4 is used to hold Signaling bit D.

10.6 Insert/Extract Signaling Bits from TxCHN[0]_n/TxSIG Pin

The XRT86L30 framer can be configured to insert/extract signaling bits provided by external equipment through the external signaling bus. When the Fractional E1 mode is enabled, this bus is configured as TxSIG and RxSIG. These pins act as an the signaling bus for the outbound E1 frames.

Figure 77 shows a timing diagram of the TxSIG input pin. **Figure 78** shows a timing diagram of the RxSIG output pin. Please note that the Signaling Bit A of a certain channel coincides with Bit 5 of the PCM data of that channel; Signaling Bit B coincides with Bit 6 of the PCM data; Signaling Bit C coincides with Bit 7 of the PCM data and Signaling Bit D coincides with Bit 8 (LSB) of the PCM data.

FIGURE 77. TIMING DIAGRAM OF THE TxSIG INPUT

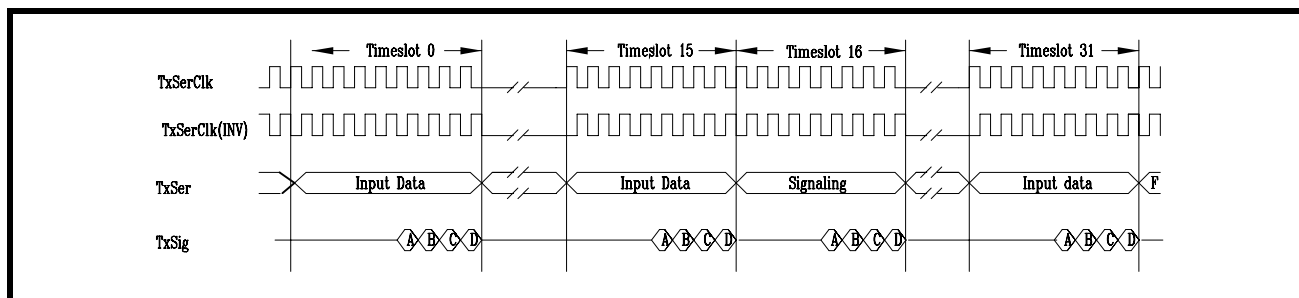
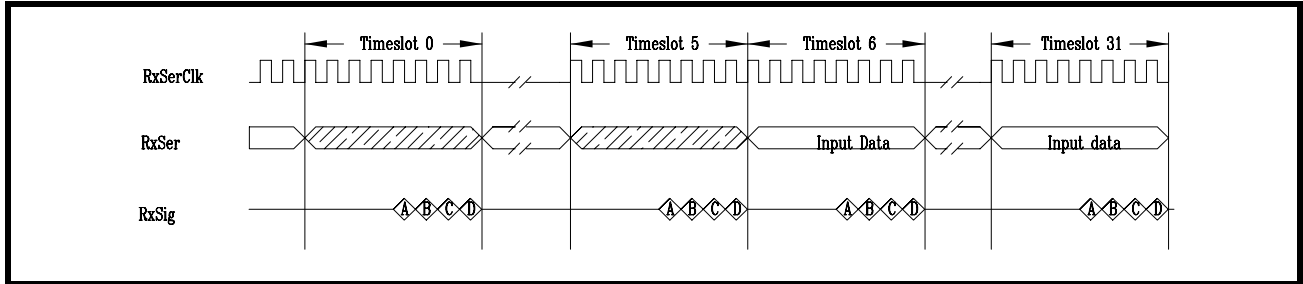

FIGURE 78. TIMING DIAGRAM OF THE RXSIG OUTPUT



10.7 Enable Channel Associated Signaling and Signaling Data Source Control

The Transmit Signaling Control Register (TSCR) of each channel selects source of signaling data to be inserted into the outgoing E1 frame and enables Channel Associated signaling. As we mentioned before, the signaling data can be inserted from Transmit Signaling Control Registers (TSCR) of each timeslot, from the TxSig_n input pin, from the TxOH_n input pin or from the TxSer_n input pin. The Transmit Signaling Data Source Select [1:0] bits of the Transmit Signaling Control Register (TSCR) determines from which sources the signaling data is inserted from.

11.0 THE DS1 TRANSMIT/RECEIVE FRAMER

11.1 Description of the Transmit/Receive Payload Data Input Interface Block

Each of the four framers within the XRT86L30 device includes a Transmit and Receive Payload Data Input Interface block. Although most configurations are independent for the Tx and Rx path, once T1 framing has been selected, both the Tx and Rx must operate in T1. The Payload Data Input Interface module (also known as the Back-plane Interface module) supports payload data to be taken from or presented to the system. In T1 modes, supported data rates are 1.544Mbit/s, MVIP 2.048Mbit/s, 4.096Mbit/s, 8.192Mbit/s, multiplexed 12.352Mbit/s, 16.384Mbit/s, HMVIP 16.384Mbit/s, or H.100 16.384Mbit/s.

11.1.1 Brief Discussion of the Transmit/Receive Payload Data Input Interface Block Operating at 1.544Mbit/s mode

Whether or not the transmit/receive interface signals have been chosen as inputs or outputs, the overall system timing diagrams remain the same. It is the responsibility of the Terminal Equipment to provide serial input data through the TxSER pin aligned with the Transmit Single-frame Synchronization signal and the Transmit Multi-frame Synchronization signal. **Figure 79** shows how to connect the Transmit Payload Data Input Interface block to local Terminal Equipment. **Figure 80** shows how to connect the Receive Payload Data Output Interface to local Terminal Equipment.

FIGURE 79. INTERFACING THE TRANSMIT PATH TO LOCAL TERMINAL EQUIPMENT

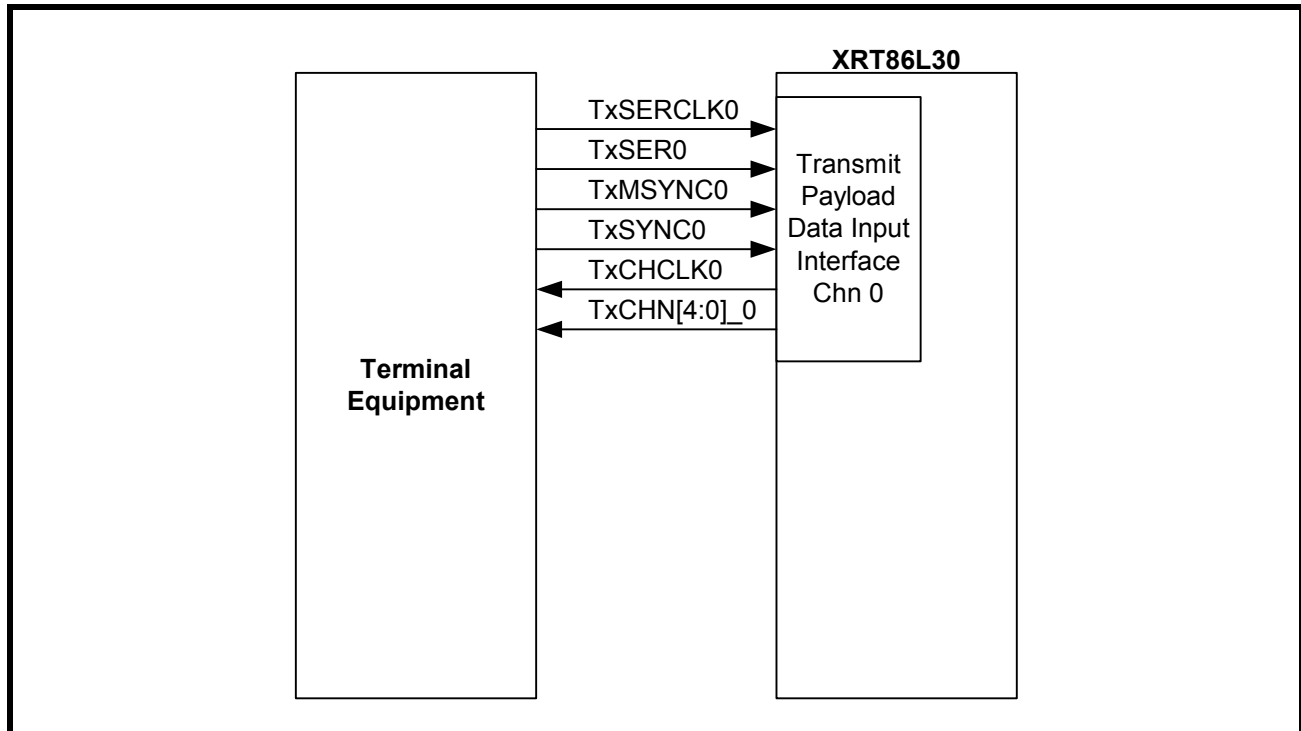

FIGURE 80. INTERFACING THE RECEIVE PATH TO LOCAL TERMINAL EQUIPMENT

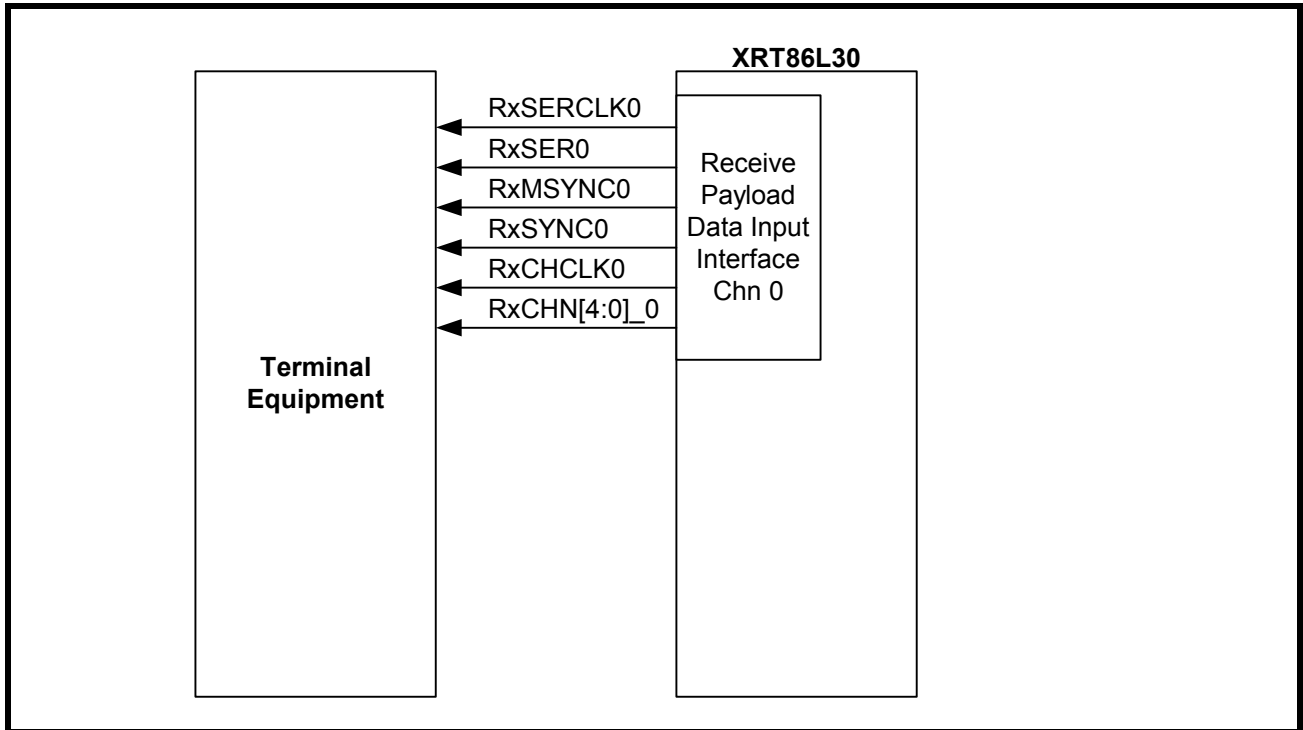

Figure 81 shows the waveforms for connecting the Transmit Payload Data Input Interface block to local Terminal Equipment. Figure 82 shows the waveforms for connecting the Receive Payload Data Input Interface block to local Terminal Equipment.

FIGURE 81. WAVEFORMS FOR CONNECTING THE TRANSMIT PAYLOAD DATA INPUT INTERFACE BLOCK TO LOCAL TERMINAL EQUIPMENT

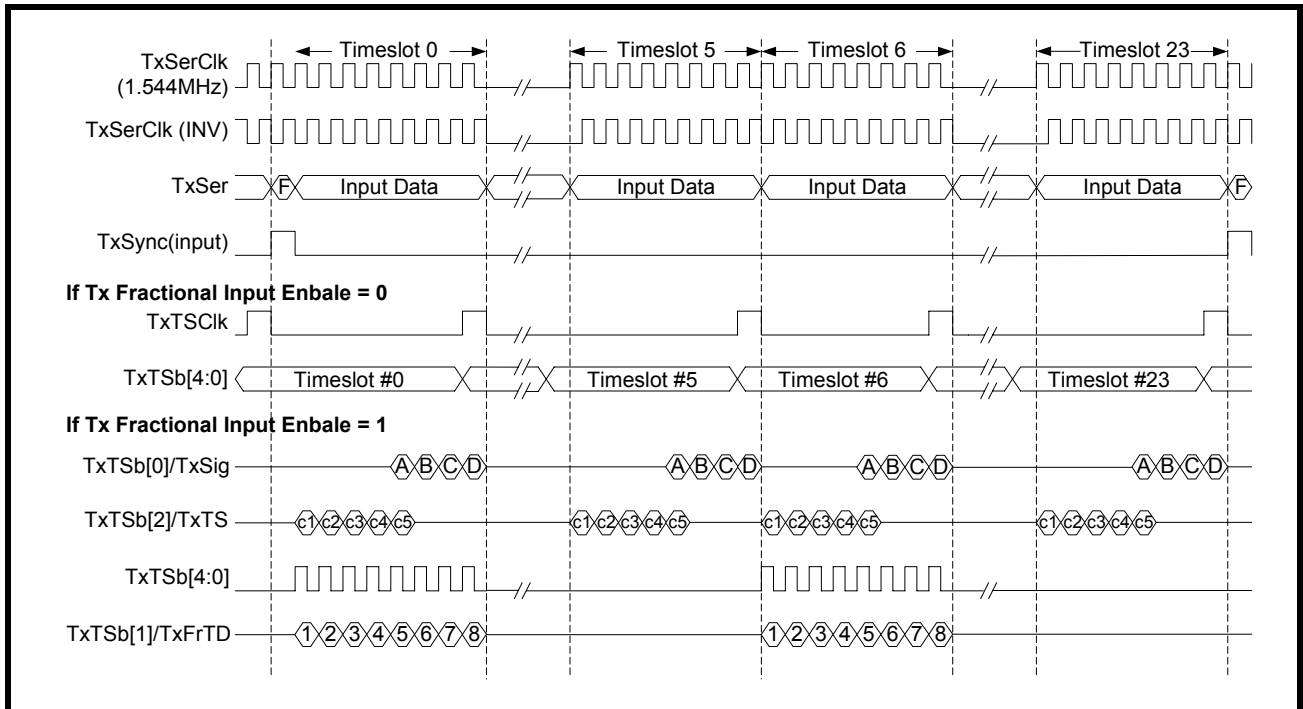
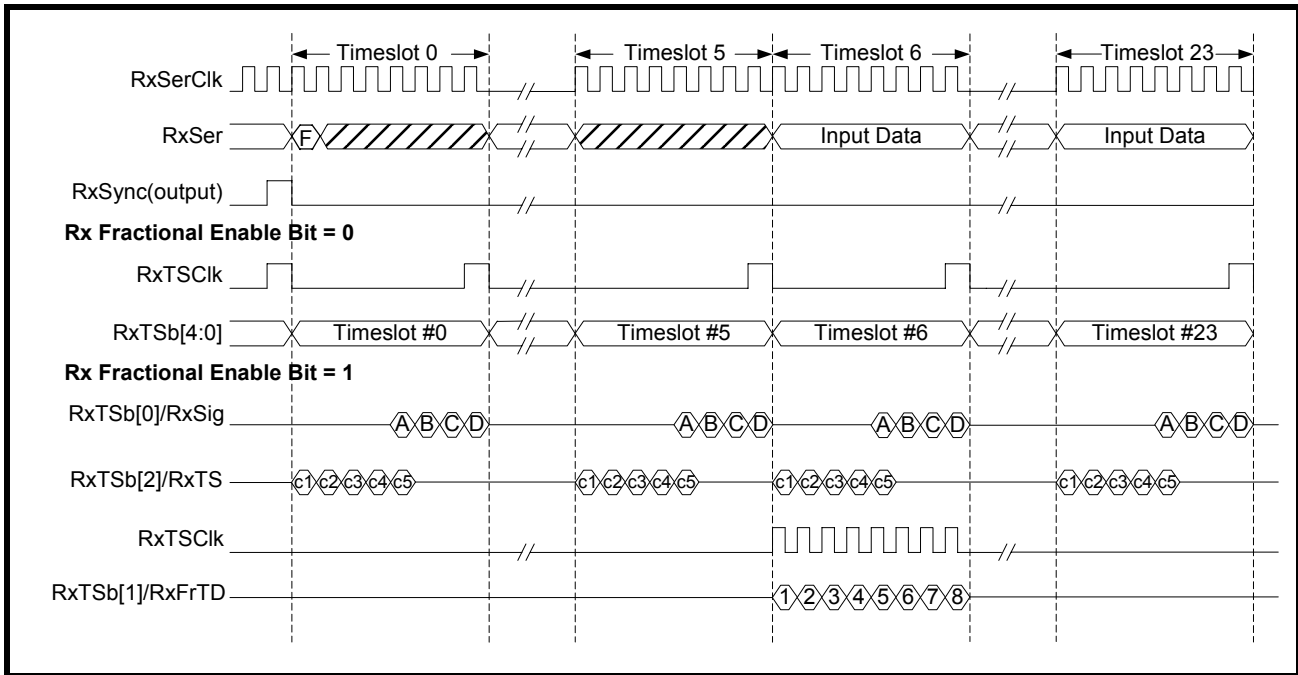

FIGURE 82. WAVEFORMS FOR CONNECTING THE RECEIVE PAYLOAD DATA INPUT INTERFACE BLOCK TO LOCAL TERMINAL EQUIPMENT



11.2 Transmit/Receive High-Speed Back-Plane Interface

The High-speed Back-plane Interface supports payload data to be taken from or presented to the Terminal Equipment at different data rates. In the non-multiplexed mode, payload data of each channel are interfaced to the Terminal Equipment separately. Each channel uses its own serial clock, serial data, single-frame synchronization signal and multi-frame synchronization signals.

11.2.1 T1 Transmit/Receive Interface - MVIP 2.048 MHz

The Back-plane interface is processing data at an E1 equivalent data rate of 2.048Mbit/s. The local Terminal Equipment should pump in data grouped in 256-bit frame 8000 times every second. Each frame consists of thirty-two octets as in E1. The local Terminal Equipment maps a 193-bit T1 frame into this 256-bit format as described below:

1. The Framing (F-bit) is mapped into MSB of the first E1 Time-slot. The local Terminal Equipment will stuff the other seven bits of the first octet with don't care bits that would be ignored by the framer.
2. Payload data of T1 Time-slot 0, 1 and 2 are mapped into E1 Time-slot 1, 2 and 3.
3. The local Terminal Equipment will stuff E1 Time-slot 4 with eight don't care bits that would be ignored by the framer.
4. Following the same rules of Step 2 and 3, the local Terminal Equipment maps every three time-slots of T1 payload data into four E1 time-slots.

The mapping of T1 frame into E1 framing format is shown in the table below.

TABLE 174: THE MAPPING OF T1 FRAME INTO E1 FRAMING FORMAT

T1	F-Bit	TS0	TS1	TS2	Don't Care Bits	TS3	TS4	TS5
E1	TS0	TS1	TS2	TS3	TS4	TS5	TS6	TS7
T1	Don't Care Bits	TS6	TS7	TS8	Don't Care Bits	TS9	TS10	TS11
E1	TS8	TS9	TS10	TS11	TS12	TS13	TS14	TS15
T1	Don't Care Bits	TS12	TS13	TS14	Don't Care Bits	TS15	TS16	TS17
E1	TS16	TS17	TS18	TS19	TS20	TS21	TS22	TS23
T1	Don't Care Bits	TS18	TS19	TS20	Don't Care Bits	TS21	TS22	TS23
E1	TS24	TS25	TS26	TS27	TS28	TS29	TS30	TS31

SINGLE T1/E1/J1 FRAMER/LIU COMBO

11.2.2 Non-Multiplexed High-Speed Mode

When the Back-plane interface data rate is MVIP 2.048Mbit/s, 4.096Mbit/s and 8.192Mbit/s, the interface signals are all configured as inputs, except the receive serial data on RxSER and the multi frame sync pulse provided by the framer. The Transmit Serial Clock for each channel is always an input clock with frequency of 1.544 MHz for all data rates so that it may be used as the timing reference for the transmit line rate. The TxMSYNC signal is configured as the Transmit Input Clock with frequencies of 2.048 MHz, 4.096 MHz and 8.192 MHz respectively. It serves as the primary clock source for the High-speed Back-plane Interface. **Figure 83** shows how to connect the Transmit non-multiplexed high-speed Input Interface block to local Terminal Equipment. **Figure 84** shows how to connect the Receive non-multiplexed high-speed Output Interface to local Terminal Equipment.

FIGURE 83. TRANSMIT NON-MULTIPLEXED HIGH-SPEED CONNECTION TO LOCAL TERMINAL EQUIPMENT USING MVIP 2.048MBIT/S, 4.096MBIT/S, OR 8.192MBIT/S

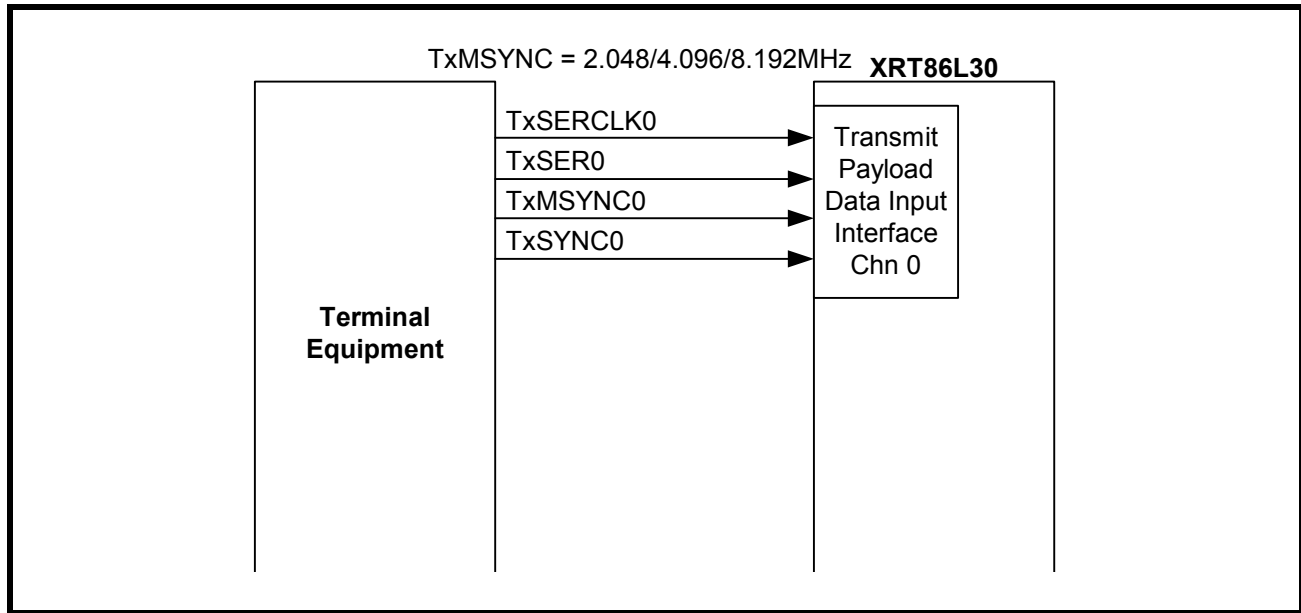

FIGURE 84. RECEIVE NON-MULTIPLEXED HIGH-SPEED CONNECTION TO LOCAL TERMINAL EQUIPMENT USING MVIP 2.048MBIT/S, 4.096MBIT/S, OR 8.192MBIT/S

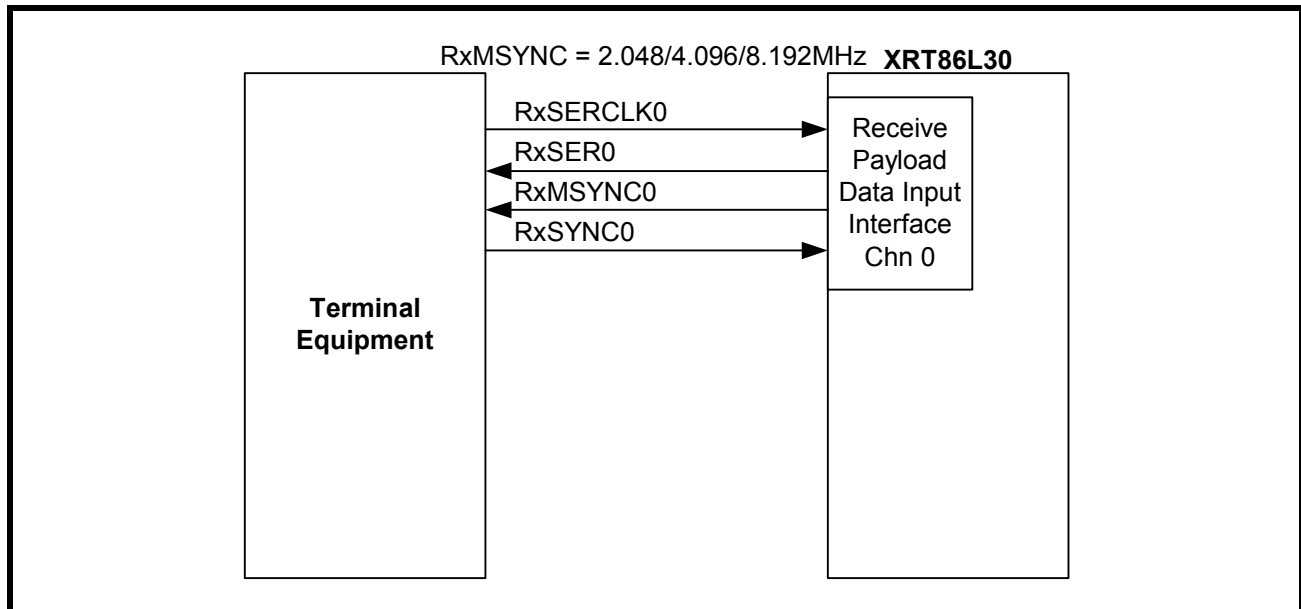

Figure 85 shows the waveforms for connecting the Transmit non-multiplexed high-speed Input Interface block to local Terminal Equipment. **Figure 86** shows the waveforms for connecting the Receive non-multiplexed high-speed Input Interface block to local Terminal Equipment.

FIGURE 85. WAVEFORMS FOR CONNECTING THE TRANSMIT NON-MULTIPLEXED HIGH-SPEED INPUT INTERFACE AT MVIP 2.048MBIT/S, 4.096MBIT/S, AND 8.192MBIT/S

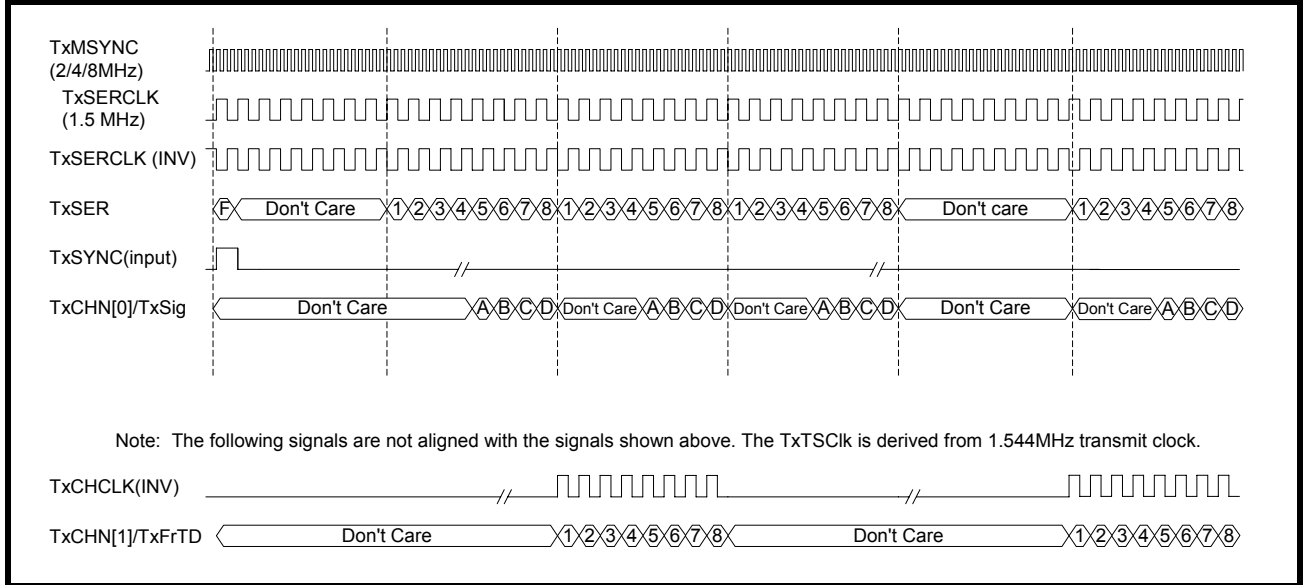
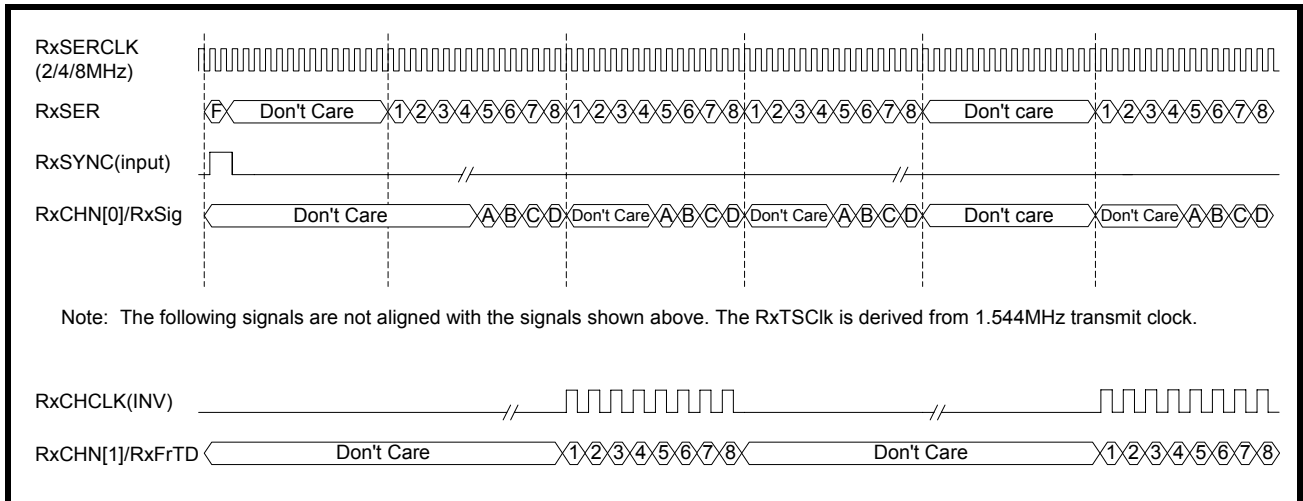

FIGURE 86. WAVEFORMS FOR CONNECTING THE RECEIVE NON-MULTIPLEXED HIGH-SPEED INPUT INTERFACE AT MVIP 2.048MBIT/S, 4.096MBIT/S, AND 8.192MBIT/S



11.2.3 Multiplexed High-Speed Mode

When the Back-plane interface data rate is 12.352Mbit/s, 16.384Mbit/s, HMVIP 16.384Mbit/s, and H.100 16.384Mbit/s, the interface signals are all configured as inputs, except the receive serial data on RxSER and the multi frame sync pulse provided by the framer. The Back-plane Interface is processing data through TxSER0 or TxSER4 pins at 12.352Mbit/s or 16.384Mbit/s. The local Terminal Equipment multiplexes payload and signaling data of every four channels into one serial data stream. Payload and signaling data of Channel 0-3 are multiplexed onto the Transmit Serial Data pin of Channel 0. Payload and signaling data of Channel 4-7 are multiplexed onto the Transmit Serial Data pin of Channel 4. Free-running clocks of 12.352MHz are supplied to the Transmit Input Clock pin of Channel 0 and Channel 4 of the framer. The local Terminal Equipment provides multiplexed payload data at rising edge of this Transmit Input Clock. The Transmit High-speed Back-plane Interface of the framer then latches incoming serial data at falling edge of the clock. The local Terminal Equipment maps four 1.544Mbit/s DS1 data streams into one 12.352Mbit/s serial data stream as described below:

1. The F-bit of four channels are repeated and grouped together to form the first octet of the multiplexed data stream. The F-bit of Channel 0 is sent first, followed by F-bit of Channel 1 and 2. The F-bit of Channel 3 is sent last. The table below shows bit-pattern of the first octet.

FIRST OCTET OF 12.352MBIT/S DATA STREAM

BIT 0	BIT 1	BIT 2	BIT 3	BIT 4	BIT 5	BIT 6	BIT 7
F ₀	F ₀	F ₁	F ₁	F ₂	F ₂	F ₃	F ₃

F_X: F-bit of Channel X

2. Payload data of four channels are repeated and grouped together in a bit-interleaved way. The first payload bit of Timeslot 0 of Channel 0 is sent first, followed by the first payload bit of Timeslot 0 of Channel 1 and 2. The first payload bit of Timeslot 0 of Channel 3 is sent last. After the first bits of Timeslot 0 of all four channels are sent, it comes the second bit of Timeslot 0 of Channel 0 and so on. The table below demonstrates how payload bits of four channels are mapped into the 12.352Mbit/s data stream.

SECOND OCTET OF 12.352MBIT/S DATA STREAM

BIT 0	BIT 1	BIT 2	BIT 3	BIT 4	BIT 5	BIT 6	BIT 7
1 ₀	1 ₀	1 ₁	1 ₁	1 ₂	1 ₂	1 ₃	1 ₃

THIRD OCTET OF 12.352MBIT/S DATA STREAM

BIT 0	BIT 1	BIT 2	BIT 3	BIT 4	BIT 5	BIT 6	BIT 7
2 ₀	2 ₀	2 ₁	2 ₁	2 ₂	2 ₂	2 ₃	2 ₃

X_Y: The Xth payload bit of Channel Y

3. The local Terminal Equipment also multiplexes signaling bits with payload bits and sends them together through the 12.352Mbit/s data stream. When the Terminal Equipment is sending the fifth payload bit of each channel, instead of sending it twice, it inserts the signaling bit A of that corresponding channel. Similarly, the sixth payload bit of a each channel is followed by the signaling bit B of that channel; the seventh payload bit is followed by the signaling bit C; the eighth payload bit is followed by the signaling bit D.

The following table illustrates how payload bits and signaling bits are multiplexed together into the 12.352Mbit/s data stream.

SIXTH OCTET OF 12.352MBIT/S DATA STREAM

BIT 0	BIT 1	BIT 2	BIT 3	BIT 4	BIT 5	BIT 6	BIT 7
5 ₀	A ₀	5 ₁	A ₁	5 ₂	A ₂	5 ₃	A ₃

SEVENTH OCTET OF 12.352MBIT/S DATA STREAM

BIT 0	BIT 1	BIT 2	BIT 3	BIT 4	BIT 5	BIT 6	BIT 7
6 ₀	B ₀	6 ₁	B ₁	6 ₂	B ₂	6 ₃	B ₃

EIGHTH OCTET OF 12.352MBIT/S DATA STREAM

BIT 0	BIT 1	BIT 2	BIT 3	BIT 4	BIT 5	BIT 6	BIT 7
7 ₀	C ₀	7 ₁	C ₁	7 ₂	C ₂	7 ₃	C ₃

NINTH OCTET OF 12.352MBIT/S DATA STREAM

BIT 0	BIT 1	BIT 2	BIT 3	BIT 4	BIT 5	BIT 6	BIT 7
8 ₀	D ₀	8 ₁	D ₁	8 ₂	D ₂	8 ₃	D ₃

X_Y: The Xth payload bit of Channel Y

A_Y: The signaling bit A of Channel Y

- Following the same rules of Step 2 and 3, the local Terminal Equipment continues to map the payload data and signaling data of four channels into a 12.352Mbit/s data stream.

The Transmit Single-frame Synchronization signal of Channel 0 pulses HIGH for one clock cycle at the first bit position (F-bit of channel 0) of the multiplexed data stream with data from Channel 0-3 multiplexed together. The Transmit Single-frame Synchronization signal of Channel 4 pulses HIGH for one clock cycle at the first bit position (F-bit of Channel 4) of the data stream with data from Channel 4-7 multiplexed together. By sampling the HIGH pulse on the Transmit Single-frame Synchronization signal, the framer can position the beginning of the multiplexed DS1 frame. It is responsibility of the Terminal Equipment to align the multiplexed transmit serial data with the Transmit Single-frame Synchronization pulse.

Inside the framer, all the "don't care" bits will be stripped away. The framing bits, signaling and payload data are de-multiplexed inside the XRT86L30 and sent to each individual channel. These data will be processed by each individual framer and send to the LIU interface. The local Terminal Equipment provides a free-running 1.544MHz clock to the Transmit Serial Input clock of each channel. The framer will use this clock to carry the processed payload and signaling data to the transmit section of the device. **Figure 87** shows how to connect the Transmit multiplexed high-speed Input Interface block to local Terminal Equipment. **Figure 88** shows how to connect the Receive multiplexed high-speed Output Interface to local Terminal Equipment.

FIGURE 87. INTERFACING XRT86L30 TRANSMIT TO LOCAL TERMINAL EQUIPMENT USING 16.384MBIT/S, HMPVIP 16.384MBIT/S, AND H.100 16.384MBIT/S

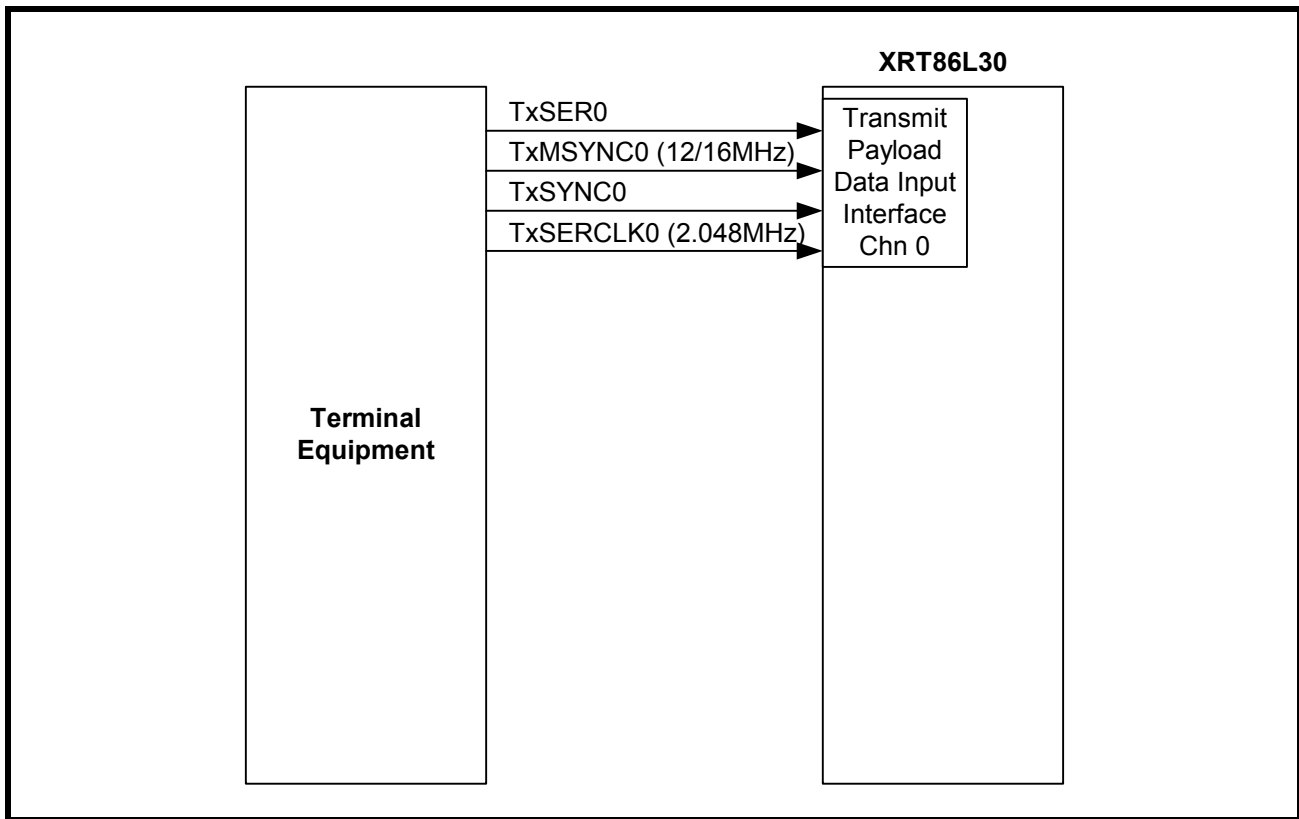

FIGURE 88. INTERFACING XRT86L30 RECEIVE TO LOCAL TERMINAL EQUIPMENT USING 16.384MBIT/S, HMVIP 16.384MBIT/S, AND H.100 16.384MBIT/S

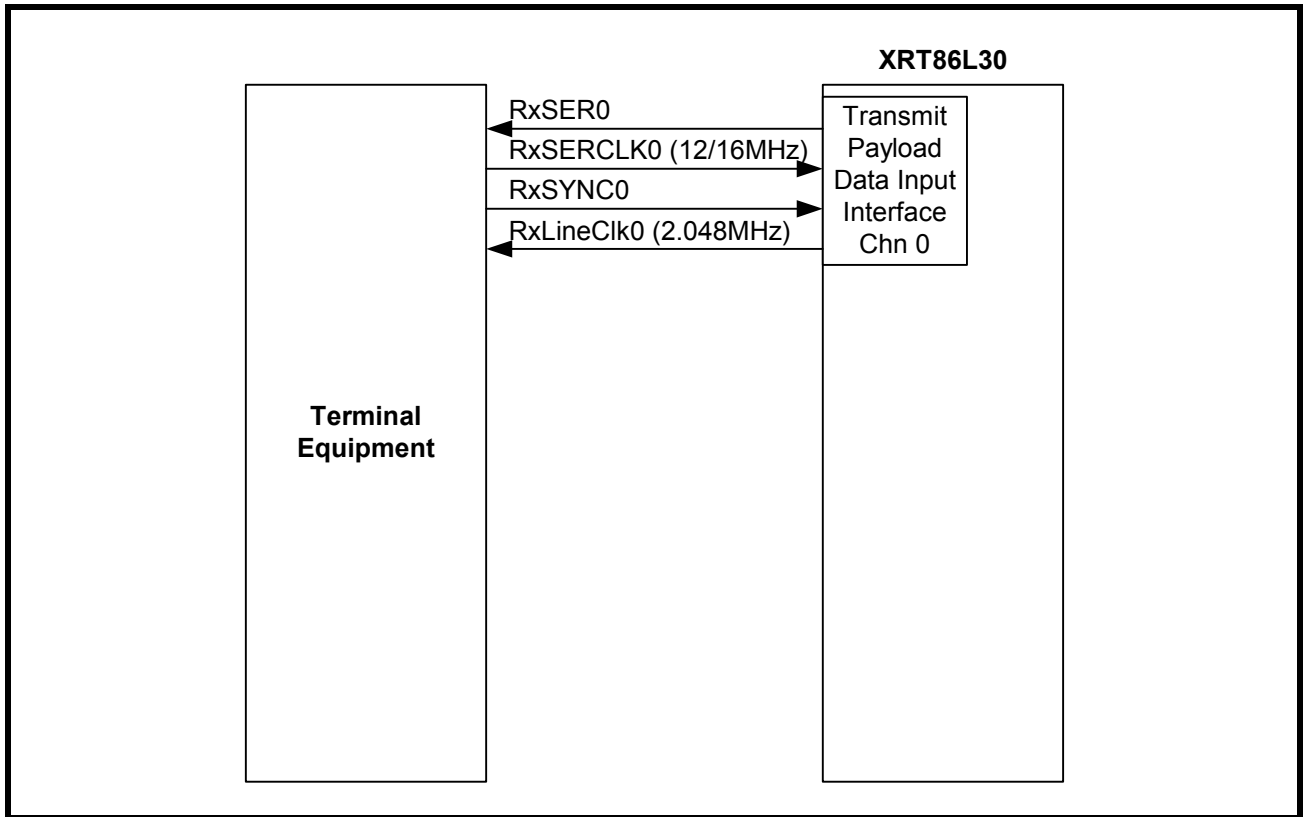

Figure 89 shows the waveforms for connecting the Transmit multiplexed high-speed Input Interface block to local Terminal Equipment at 12.352Mbit/s. Figure 91 shows the waveforms for connecting the Transmit multiplexed high-speed Input Interface block to local Terminal Equipment for 16.384Mbit/s. Figure 95 shows the waveforms for connecting the Transmit multiplexed high-speed Input Interface block to local Terminal Equipment for HMVIP and H.100. Figure 92 shows the waveforms for connecting the Receive multiplexed high-speed Input Interface block to local Terminal Equipment for 12.352MHz. Figure 93 shows the waveforms for connecting the Receive multiplexed high-speed Input Interface block to local Terminal Equipment for 16.384MHz. Figure 94 shows the waveforms for connecting the Receive multiplexed high-speed Input Interface block to local Terminal Equipment for HMVIP 16.384MHz. Figure 95 shows the waveforms for connecting the Receive multiplexed high-speed Input Interface block to local Terminal Equipment for H.100 16.384MHz.

FIGURE 89. WAVEFORMS FOR CONNECTING THE TRANSMIT MULTIPLEXED HIGH-SPEED INPUT INTERFACE AT 12.352MBIT/S MODE

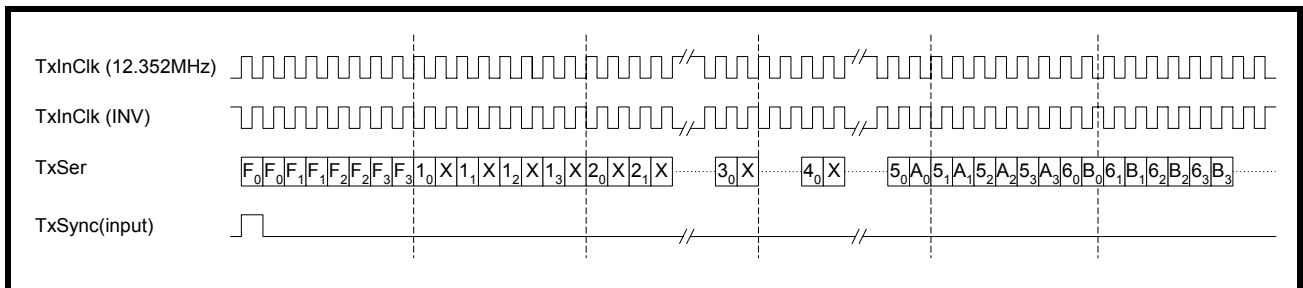

FIGURE 90. WAVEFORMS FOR CONNECTING THE TRANSMIT MULTIPLEXED HIGH-SPEED INPUT INTERFACE AT 16.384MBIT/S MODE

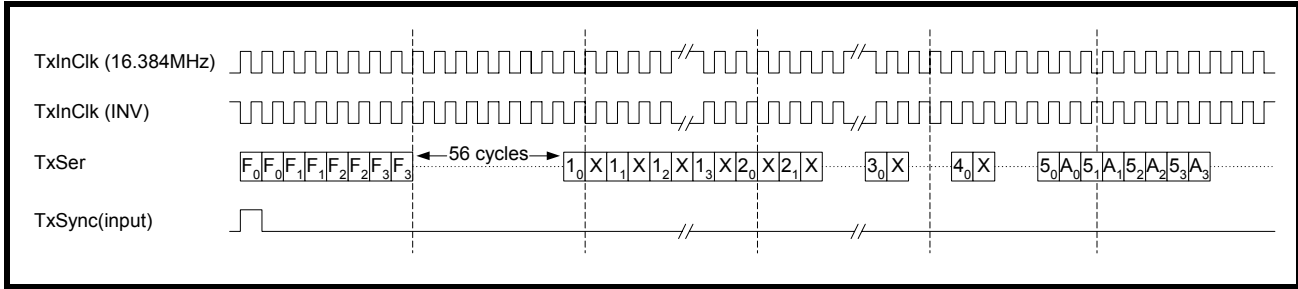

FIGURE 91. WAVEFORMS FOR CONNECTING THE TRANSMIT MULTIPLEXED HIGH-SPEED INPUT INTERFACE AT HMVIP AND H.100 16.384MBIT/S MODE

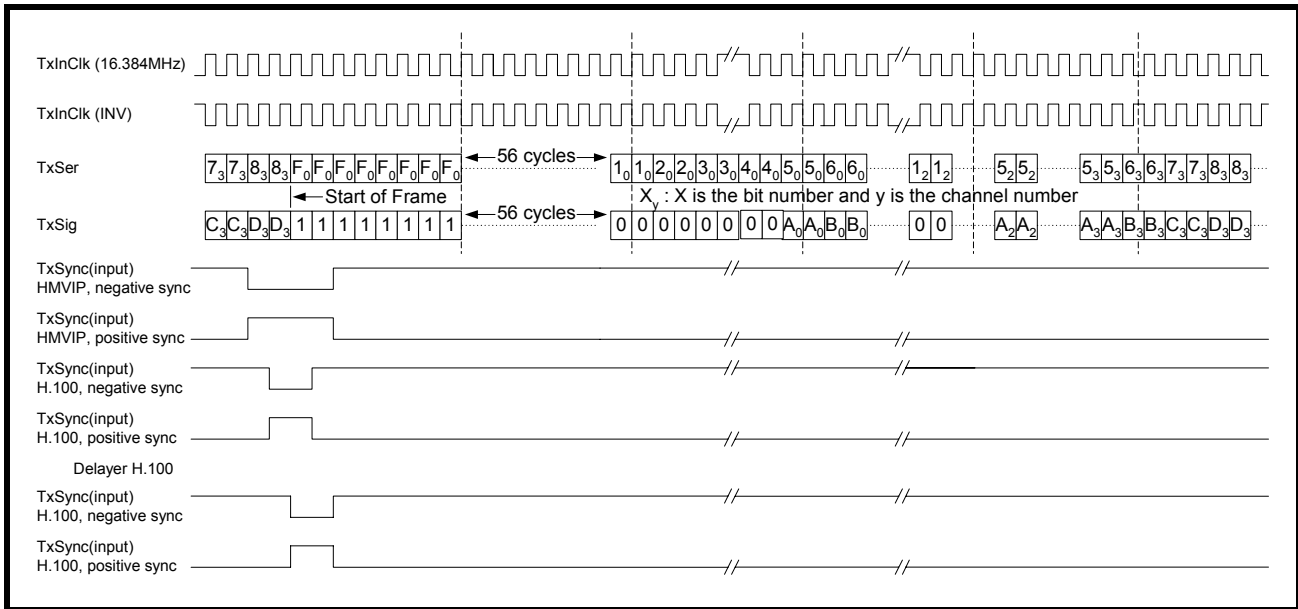

FIGURE 92. WAVEFORMS FOR CONNECTING THE RECEIVE MULTIPLEXED HIGH-SPEED INPUT INTERFACE AT 12.352MBIT/S MODE

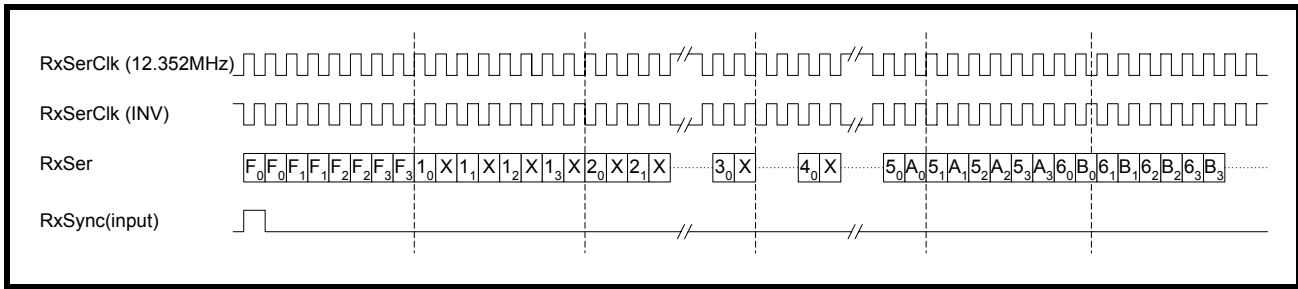

FIGURE 93. WAVEFORMS FOR CONNECTING THE RECEIVE MULTIPLEXED HIGH-SPEED INPUT INTERFACE AT 16.384MBIT/S MODE

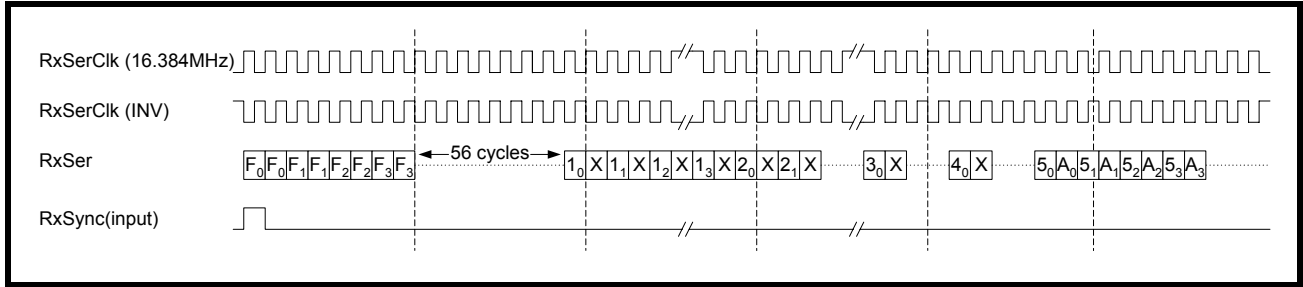

FIGURE 94. WAVEFORMS FOR CONNECTING THE RECEIVE MULTIPLEXED HIGH-SPEED INPUT INTERFACE AT HMVIP 16.384MBIT/S MODE

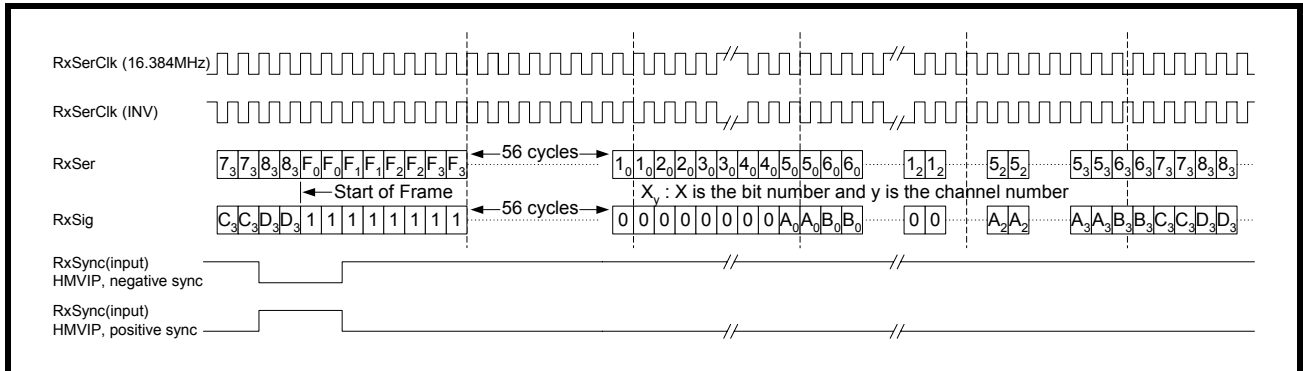
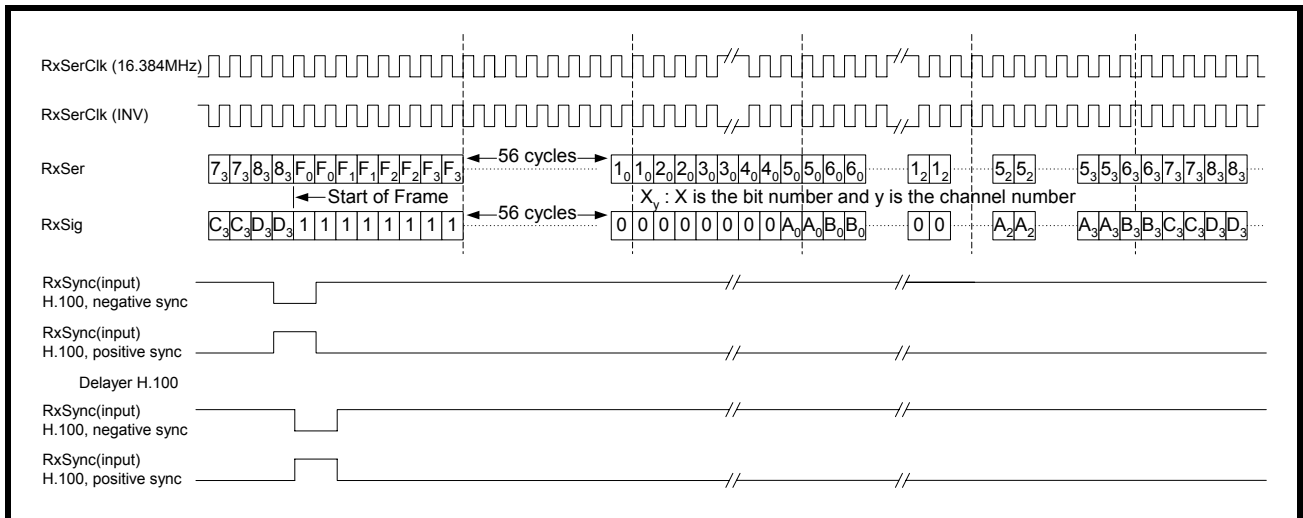

FIGURE 95. WAVEFORMS FOR CONNECTING THE RECEIVE MULTIPLEXED HIGH-SPEED INPUT INTERFACE AT H.100 16.384MBIT/S MODE



11.3 *Brief Discussion of Robbed-bit Signaling in DS1 Framing Format*

Signaling is required when dealing with voice and dial-up data services in DS1 applications. Traditionally, signaling is provided on a dial-up telephone line, across the talk-path. Bit robbing, or stealing the least significant bit (8th bit) in each of the twenty-four voice channels in the signaling frames allows enough bits to signal between the transmitting and receiving end. That is where the name Robbed-bit signaling comes from. These ends can be CPE to central office (CO) for switched services, or CPE to CPE for PBX-to-PBX connections.

Signaling is used to tell the receiver where the call or route is destined. The signal is sent through switches along the route to a distant end. Common types of signals are:

- On hook
- Off hook
- Dial tone
- Dialed digits
- Ringing cycle
- Busy tone

Robbed-bit Signaling is supported in three DS1 framing formats.

- Super-Frame (SF)
- SLC@96
- Extended Super-Frame (ESF)

In Super-Frame or SLC@96 framing mode, frame number 6 and frame number 12 are signaling frames. In channelized DS1 applications, these frames are used to contain the signaling information. In frame number 6 and 12, the least significant bit of all twenty-four timeslots is 'robbed' to carry call state information. The bit in frame 6 is called the A bit and the bit in frame 12 is called the B bit. The combination of A and B defines the state of the call for the particular timeslot that these two bits are located in.

FRAME NUMBER	SIGNALING BIT
6	A
12	B

In Extended Super-Frame framing mode, frame number 6, 12, 18 and 24 are signaling frames. In these frames, the least significant bit of all twenty-four timeslots is 'robbed' to carry call state information. The bit in frame 6 is called the A bit, the bit in frame 12 is called the B bit, the bit in frame 18 is called the C bit and the bit in frame 24 is called the D bit. The combination of A, B, C and D defines the state of the call for the particular timeslot that these signaling bits are located in.

FRAME NUMBER	SIGNALING BIT
6	A
12	B
18	C
24	D

11.3.1 **Configure the framer to transmit Robbed-bit Signaling**

The XRT86L30 framer supports transmission of Robbed-bit Signaling in ESF, SF and SLC@96 framing formats. Signaling bits can be inserted into the outgoing DS1 frame through the following:

- Signaling data is inserted from Transmit Signaling Control Registers (TSCR) of each timeslot
- Signaling data is inserted from TxSig_n pin

- Signaling data is embedded into the input PCM data coming from the Terminal Equipment

11.3.2 Insert Signaling Bits from TSCR Register

The four most significant bits of the Transmit Signaling Control Register (TSCR) of each timeslot can be used to store outgoing signaling data. The user can program these bits through the microprocessor access. If the XRT86L30 framer is configured to insert signaling bits from the TSCR registers, the DS1 Transmit Framing block will strip off the least significant bits of each time slot in the signaling frames and replace it with the signaling bit stored inside the TSCR registers. The insertion of signaling bits into PCM data is done on a per-channel basis.

In SF or SLC@96 mode, the user can control the XRT86L30 framer to transmit no signaling (transparent), two-code signaling, or four-code signaling. Two-code signaling is done by substituting the least significant bit (LSB) of the specific channel in frame 6 and 12 with the content of the Signaling bit A of the specific TSCR register.

Four-code signaling is done by substituting the LSB of channel data in frame 6 with the Signaling bit A and the LSB of channel data in frame 12 with the Signaling bit B of the specific channel's TSCR register. If sixteen-code signaling is selected in SF format, only the Signaling bit A and Signaling bit B information are used.

In ESF mode, the user can control the XRT86L30 framer to transmit no signaling (transparent) by disable signaling insertion, two-code signaling, four-code signaling or sixteen code signaling. Two-code signaling is done by substituting the least significant bit (LSB) of the specific channel in frame 6, 12, 18 and 24 with the content of the Signaling bit A of the specific TSCR register.

Four-code signaling is done by substituting the LSB of channel data in frame 6 and frame 18 with the Signaling bit A and the LSB of channel data in frame 12 and frame 24 with the Signaling bit B of the specific channel's TSCR register.

Sixteen-code signaling is implemented by substituting the LSB of channel data in frames 6, 12, 18, and 24 with the content of Signaling bit A, B, C, and D of TSCR register respectively.

In N or T1DM modes, no robbed-bit signaling is allowed and the transmit data stream remains intact.

The table below shows the four most significant bits of the Transmit Signaling Control Register.

TRANSMIT SIGNALING CONTROL REGISTER (TSCR) (ADDRESS = 0X0340H - 0X0357H)

BIT NUMBER	BIT NAME	BIT TYPE	BIT DESCRIPTION
7	Signaling Bit A	R/W	This bit is used to store Signaling Bit A that is sent as the least significant bit of timeslot of frame number 6.
6	Signaling Bit B	R/W	This bit is used to store Signaling Bit B that is sent as the least significant bit of timeslot of frame number 12.
5	Signaling Bit C	R/W	This bit is used to store Signaling Bit C that is sent as the least significant bit of timeslot of frame number 18.
4	Signaling Bit D	R/W	This bit is used to store Signaling Bit D that is sent as the least significant bit of timeslot of frame number 24.

11.3.3 Insert Signaling Bits from TxSig_n Pin

The XRT86L30 framer can be configured to insert signaling bits provided by external equipment through the TxSig_n pins. This pin is a multiplexed I/O pin with two functions:

- TxCHN[0]_n - Transmit Timeslot Number Bit [0] Output pin
- TxSig_n - Transmit Signaling Input pin

When the Transmit Fractional DS1 bit of the Transmit Interface Control Register (TICR) is set to 0, this pin is configured as TxTSb[0]_n pin, it outputs bit 0 of the timeslot number of the DS1 PCM data that is transmitting.

SINGLE T1/E1/J1 FRAMER/LIU COMBO

When the Transmit Fractional DS1 bit of the Transmit Interface Control Register (TICR) is set to 1, this pin is configured as TxSig_n pin, it acts as an input source for the signaling bits to be transmitted in the outbound DS1 frames.

Figure 96 below is a timing diagram of the TxSig_n input pin. Please note that the Signaling Bit A of a certain timeslot coincides with Bit 4 of the PCM data; Signaling Bit B coincides with Bit 5 of the PCM data; Signaling Bit C coincides with Bit 6 of the PCM data and Signaling Bit D coincides with Bit 7 (LSB) of the PCM data.

FIGURE 96. TIMING DIAGRAM OF THE TXSIG_N INPUT

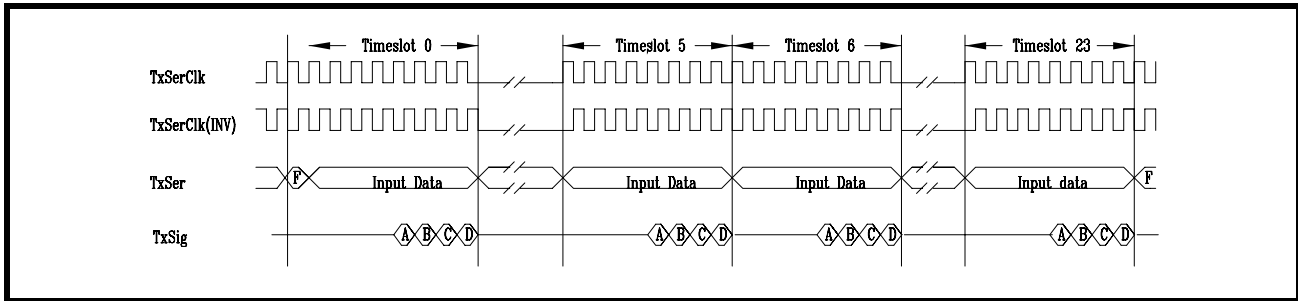

The table below shows configurations of the Transmit Fractional DS1 bit of the Transmit Interface Control Register (TICR).

TRANSMIT INTERFACE CONTROL REGISTER (TICR)(ADDRESS = 0X0120H)

BIT NUMBER	BIT NAME	BIT TYPE	BIT DESCRIPTION
4	Transmit Fractional DS1	R/W	This READ/WRITE bit-field permits the user to determine which one of the two functions the multiplexed I/O pin of TxTSb[0]_n/TxSig_n is spotting. 0 - This pin is configured as TxTSb[0]_n pin, it outputs bit 0 of the timeslot number of the DS1 PCM data that is transmitting. 1 - This pin is configured as TxSig_n pin, it acts as an input source for the signaling bits to be transmitted in the outbound DS1 frames

12.0 ALARMS AND ERROR CONDITIONS

The XRT86L30 T1/J1/E1 quad Framer can be configured to monitor quality of received DS1 frames. It can generate error indicators if the local receive framer has received error frames from the remote terminal. If corresponding interrupt is enabled, the local microprocessor operation is interrupted by these error conditions. Upon microprocessor interruption, the user can intervene by looking into the error conditions.

At the same time, the user can configure the XRT86L30 framer to transmit alarms and error indications to remote terminal. Different alarms and error indications will be transmitted depending on the error condition.

The section below gives a brief discussion of the error conditions that can be detected by the XRT86L30 framer and error indications that will be generated.

12.1 AIS Alarm

As we discussed before, transmission of Alarm Indication Signal (AIS) or Blue Alarm by the intermediate node indicates that the equipment is still functioning but unable to offer services. It is an all ones (except for framing bits) pattern which can be used by the equipment further down the line to maintain clock recovery and timing synchronization.

The XRT86L30 framer can detect two types of AIS in DS1 mode:

- Framed AIS
- Unframed AIS

Unframed AIS is an all ones pattern. If unframed AIS is sent, the equipment further down the line will be able to maintain timing synchronization and be able to recover clock from the received AIS signal. However, due to the lack of framing bits, the equipment farther down the line will not be able to maintain frame synchronization and will declare Loss of Frame (LOF).

On the other hand, the payload portion of a framed AIS pattern is all ones. However, a framed AIS pattern still has correct framing bits. Therefore, the equipment further down the line can still maintain frame synchronization as well as timing synchronization. In this case, no LOF or Red alarm will be declared.

The Alarm indication logic within the Receive Framer block of the XRT86L30 framer monitors the incoming DS1 frames for AIS. AIS alarm condition are detected and declared according to the following procedure:

1. The incoming DS1 frames are monitored for AIS detection. AIS detection is defined as an unframed or framed pattern with less than three zeros in two consecutive frames.
2. An AIS detection counter within the Receive Framer block of the XRT86L30 counts the occurrences of AIS detection over a 6 ms interval. It will indicate a valid AIS flag when twenty-two or more of a possible twenty-four AIS are detected.
3. Each 6 ms interval with a valid AIS flag increments a flag counter which declares AIS alarm when 255 valid flags have been collected.

Therefore, AIS condition has to be persisted for 1.53 seconds before AIS alarm condition is declared by the XRT86L30 framer.

If there is no valid AIS flag over a 6ms interval, the Alarm indication logic will decrement the flag counter. The AIS alarm is removed when the counter reaches 0. That is, AIS alarm will be removed if over 1.53 seconds, there is no valid AIS flag.

SINGLE T1/E1/J1 FRAMER/LIU COMBO

The Alarm Indication Signal Detection Select bits of the Alarm Generation Register (AGR) enable the two types of AIS detection that are supported by the XRT86L30 framer. The table below shows configurations of the Alarm Indication Signal Detection Select bits of the Alarm Generation Register (AGR).

ALARM GENERATION REGISTER (AGR) (ADDRESS = 0X0108H)

BIT NUMBER	BIT NAME	BIT TYPE	BIT DESCRIPTION
1-0	AIS Detection Select	R/W	00 - AIS alarm detection is disabled. When this bit is set to 01: Detection of unframed AIS alarm of all ones pattern is enabled. 10 - AIS alarm detection is disabled. When this bit is set to 00: Detection of framed AIS alarm of all ones pattern except for framing bits is enabled.

If detection of unframed or framed AIS alarm is enabled by the user and if AIS is present in the incoming DS1 frame, the XRT86L30 framer can generate a Receive AIS State Change interrupt associated with the setting of Receive AIS State Change bit of the Alarm and Error Status Register to one.

To enable the Receive AIS State Change interrupt, the Receive AIS State Change Interrupt Enable bit of the Alarm and Error Interrupt Enable Register (AEIER) have to be set to one. In addition, the Alarm and Error Interrupt Enable bit of the Block Interrupt Enable Register (BIER) needs to be one.

The table below shows configurations of the Receive AIS State Change Interrupt Enable bit of the Alarm and Error Interrupt Enable Register (AEIER).

ALARM AND ERROR INTERRUPT ENABLE REGISTER (AEIER) (ADDRESS = 0X0B03H)

BIT NUMBER	BIT NAME	BIT TYPE	BIT DESCRIPTION
1	Receive AIS State Change Interrupt Enable	R/W	0 - The Receive AIS State Change interrupt is disabled. 1 - The Receive AIS State Change interrupt is enabled.

The table below shows configurations of the Alarm and Error Interrupt Enable bit of the Block Interrupt Enable Register.

BLOCK INTERRUPT ENABLE REGISTER (BIER) (ADDRESS = 0X0B01H)

BIT NUMBER	BIT NAME	BIT TYPE	BIT DESCRIPTION
1	Alarm and Error Interrupt Enable	R/W	0 - Every interrupt generated by the Alarm and Error Interrupt Status Register (AEISR) is disabled. 1 - Every interrupt generated by the Alarm and Error Interrupt Status Register (AEISR) is enabled.

When these interrupt enable bits are set and AIS is present in the incoming DS1 frame, the XRT86L30 framer will declare AIS by doing the following:

- Set the read-only Receive AIS State bit of the Alarm and Error Status Register (AESR) to one indicating there is AIS alarm detected in the incoming DS1 frame.
- Set the Receive AIS State Change bit of the Alarm and Error Status Register to one indicating there is a change in state of AIS. This status indicator is valid until the Framer Interrupt Status Register is read.

Reading this register clears the associated interrupt if Reset-Upon-Read is selected in Interrupt Control Register (ICR). Otherwise, a write-to-clear operation by the microprocessor is required to reset these status indicators.

The table below shows the Receive AIS State Change status bits of the Alarm and Error Status Register.

ALARM AND ERROR STATUS REGISTER (AESR) (ADDRESS = 0X0B02H)

BIT NUMBER	BIT NAME	BIT TYPE	BIT DESCRIPTION
1	Receive AIS State Change	RUR / WC	0 - There is no change of AIS state in the incoming DS1 payload data. 1 - There is change of AIS state in the incoming DS1 payload data.

The Receive AIS State bit of the Alarm and Error Status Register (AESR), on the other hand, is a read-only bit indicating there is AIS alarm detected in the incoming DS1 frame.

The table below shows the Receive AIS State status bits of the Alarm and Error Status Register.

ALARM AND ERROR STATUS REGISTER (AESR) (ADDRESS = 0X0B02H)

BIT NUMBER	BIT NAME	BIT TYPE	BIT DESCRIPTION
6	Receive AIS State	R	0 - There is no AIS alarm condition detected in the incoming DS1 payload data. 1 - There is AIS alarm condition detected in the incoming DS1 payload data.

12.2 Red Alarm

The Alarm indication logic within the Receive Framer block of the XRT86L30 framer monitors the incoming DS1 frames for red alarm or Loss of Frame (LOF) condition. Red alarm condition are detected and declared according to the following procedure:

1. The red alarm is detected by monitoring the occurrence of Loss of Frame (LOF) over a 6 ms interval.
2. An LOF valid flag will be posted on the interval when one or more LOF occurred during the interval.
3. Each interval with a valid LOF flag increments a flag counter which declares RED alarm when 63 valid intervals have been accumulated.
4. An interval without valid LOF flag decrements the flag counter. The Red alarm is removed when the counter reaches zero.

If LOF condition is present in the incoming DS1 frame, the XRT86L30 framer can generate a Receive Red Alarm State Change interrupt associated with the setting of Receive Red Alarm State Change bit of the Alarm and Error Status Register to one.

To enable the Receive Red Alarm State Change interrupt, the Receive Red Alarm State Change Interrupt Enable bit of the Alarm and Error Interrupt Enable Register (AEIER) has to be set to one. In addition, the Alarm and Error Interrupt Enable bit of the Block Interrupt Enable Register (BIER) needs to be one.

The table below shows configurations of the Receive Red Alarm State Change Interrupt Enable bit of the Alarm and Error Interrupt Enable Register (AEIER).

ALARM AND ERROR INTERRUPT ENABLE REGISTER (AEIER) (ADDRESS = 0X0B03H)

BIT NUMBER	BIT NAME	BIT TYPE	BIT DESCRIPTION
2	Receive Red Alarm State Change Interrupt Enable	R/W	0 - The Receive Red Alarm State Change interrupt is disabled. No Receive Loss of Frame (RxLOF) interrupt will be generated upon detection of LOF condition. 1 - The Receive Red Alarm State Change interrupt is enabled. Receive Loss of Frame (RxLOF) interrupt will be generated upon detection of LOF condition.

SINGLE T1/E1/J1 FRAMER/LIU COMBO

The table below shows configurations of the Alarm and Error Interrupt Enable bit of the Block Interrupt Enable Register.

BLOCK INTERRUPT ENABLE REGISTER (BIER) (ADDRESS = 0X0B01H)

BIT NUMBER	BIT NAME	BIT TYPE	BIT DESCRIPTION
1	Alarm and Error Interrupt Enable	R/W	0 - Every interrupt generated by the Alarm and Error Interrupt Status Register (AEISR) is disabled. 1 - Every interrupt generated by the Alarm and Error Interrupt Status Register (AEISR) is enabled.

When these interrupt enable bits are set and Red Alarm is present in the incoming DS1 frame, the XRT86L30 framer will declare Red Alarm by doing the following:

- Set the read-only Receive Red Alarm State bit of the Alarm and Error Status Register (AESR) to one indicating there is Red Alarm detected in the incoming DS1 frame.
- Set the Receive Red Alarm State Change bit of the Alarm and Error Status Register to one indicating there is a change in state of Red Alarm. This status indicator is valid until the Framer Interrupt Status Register is read.

Reading this register clears the associated interrupt if Reset-Upon-Read is selected in Interrupt Control Register (ICR). Otherwise, a write-to-clear operation by the microprocessor is required to reset these status indicators.

The table below shows the Receive Red Alarm State Change status bits of the Alarm and Error Status Register.

ALARM AND ERROR STATUS REGISTER (AESR) (ADDRESS = 0X0B02H)

BIT NUMBER	BIT NAME	BIT TYPE	BIT DESCRIPTION
2	Receive Red Alarm State Change	RUR / WC	0 - There is no change of Red Alarm state in the incoming DS1 payload data. 1 - There is change of Red Alarm state in the incoming DS1 payload data.

The Receive Red Alarm State bit of the Alarm and Error Status Register (AESR), on the other hand, is a read-only bit indicating there is Red Alarm detected in the incoming DS1 frame.

The table below shows the Receive Red Alarm State status bits of the Alarm and Error Status Register.

ALARM AND ERROR STATUS REGISTER (AESR) (ADDRESS = 0X0B02H)

BIT NUMBER	BIT NAME	BIT TYPE	BIT DESCRIPTION
7	Receive Red Alarm State	R	0 - There is no Red Alarm condition detected in the incoming DS1 payload data. 1 - There is Red Alarm condition detected in the incoming DS1 payload data.

12.3 Yellow Alarm

The Alarm indication logic within the Receive Framer block of the XRT86L30 framer monitors the incoming DS1 frames for Yellow Alarm condition. The yellow alarm is detected and declared according to the following procedure:

1. Monitor the occurrence of Yellow Alarm pattern over a 6 ms interval. A YEL valid flag will be posted on the interval when Yellow Alarm pattern occurred during the interval.

2. Each interval with a valid YEL flag increments a flag counter which declares YEL alarm when 80 valid intervals have been accumulated.
3. An interval without valid YEL flag decrements the flag counter. The YEL alarm is removed when the counter reaches zero.

If Yellow Alarm condition is present in the incoming DS1 frame, the XRT86L30 framer can generate a Receive Yellow Alarm State Change interrupt associated with the setting of Receive Yellow Alarm State Change bit of the Alarm and Error Status Register to one.

To enable the Receive Yellow Alarm State Change interrupt, the Receive Yellow Alarm State Change Interrupt Enable bit of the Alarm and Error Interrupt Enable Register (AEIER) has to be set to one. In addition, the Alarm and Error Interrupt Enable bit of the Block Interrupt Enable Register (BIER) needs to be one.

The table below shows configurations of the Receive Yellow Alarm State Change Interrupt Enable bit of the Alarm and Error Interrupt Enable Register (AEIER).

ALARM AND ERROR INTERRUPT ENABLE REGISTER (AEIER) (ADDRESS = 0X0B03H)

BIT NUMBER	BIT NAME	BIT TYPE	BIT DESCRIPTION
0	Receive Yellow Alarm State Change Interrupt Enable	R/W	0 - The Receive Yellow Alarm State Change interrupt is disabled. Any state change of Receive Yellow Alarm will not generate an interrupt. 1 - The Receive Yellow Alarm State Change interrupt is enabled. Any state change of Receive Yellow Alarm will generate an interrupt.

The table below shows configurations of the Alarm and Error Interrupt Enable bit of the Block Interrupt Enable Register.

BLOCK INTERRUPT ENABLE REGISTER (BIER) (ADDRESS = 0X0B01H)

BIT NUMBER	BIT NAME	BIT TYPE	BIT DESCRIPTION
1	Alarm and Error Interrupt Enable	R/W	0 - Every interrupt generated by the Alarm and Error Interrupt Status Register (AEISR) is disabled. 1 - Every interrupt generated by the Alarm and Error Interrupt Status Register (AEISR) is enabled.

When these interrupt enable bits are set and Yellow Alarm is present in the incoming DS1 frame, the XRT86L30 framer will declare Yellow Alarm by doing the following:

- Set the read-only Receive Yellow Alarm State bit of the Alarm and Error Status Register (AESR) to one indicating there is Yellow Alarm detected in the incoming DS1 frame.
- Set the Receive Yellow Alarm State Change bit of the Alarm and Error Status Register to one indicating there is a change in state of Yellow Alarm. This status indicator is valid until the Framer Interrupt Status Register is read.

Reading this register clears the associated interrupt if Reset-Upon-Read is selected in Interrupt Control Register (ICR). Otherwise, a write-to-clear operation by the microprocessor is required to reset these status indicators.

SINGLE T1/E1/J1 FRAMER/LIU COMBO

The table below shows the Receive Yellow Alarm State Change status bits of the Alarm and Error Status Register.

ALARM AND ERROR STATUS REGISTER (AESR)(ADDRESS = 0X0B02H)

BIT NUMBER	BIT NAME	BIT TYPE	BIT DESCRIPTION
0	Receive Yellow Alarm State Change	RUR / WC	0 - There is no change of Yellow Alarm state in the incoming DS1 payload data. 1 - There is change of Yellow Alarm state in the incoming DS1 payload data.

The table below shows the Receive AIS State Change status bits of the Alarm and Error Status Register. The Receive Yellow Alarm State bit of the Alarm and Error Status Register (AESR), on the other hand, is a read-only bit indicating there is Yellow Alarm detected in the incoming DS1 frame.

The table below shows the Receive Yellow Alarm State status bits of the Alarm and Error Status Register.

ALARM AND ERROR STATUS REGISTER (AESR) (ADDRESS = 0X0B02H)

BIT NUMBER	BIT NAME	BIT TYPE	BIT DESCRIPTION
5	Receive Yellow Alarm State	R	0 - There is no Yellow Alarm condition detected in the incoming DS1 payload data. 1 - There is Yellow Alarm condition detected in the incoming DS1 payload data.

12.4 Bipolar Violation

The line coding for the DS1 signal should be bipolar. That is, a binary "0" is transmitted as zero volts while a binary "1" is transmitted as either a positive or negative pulse, opposite in polarity to the previous pulse. A Bipolar Violation or BPV occurs when the alternate polarity rule is violated. The Alarm indication logic within the Receive Framer block of the XRT86L30 framer monitors the incoming DS1 frames for Bipolar Violations.

If a Bipolar Violation is present in the incoming DS1 frame, the XRT86L30 framer can generate a Receive Bipolar Violation interrupt associated with the setting of Receive Bipolar Violation bit of the Alarm and Error Status Register to one.

To enable the Receive Bipolar Violation interrupt, the Receive Bipolar Violation Interrupt Enable bit of the Alarm and Error Interrupt Enable Register (AEIER) has to be set to one. In addition, the Alarm and Error Interrupt Enable bit of the Block Interrupt Enable Register (BIER) needs to be one.

The table below shows configurations of the Receive Bipolar Violation Interrupt Enable bit of the Alarm and Error Interrupt Enable Register (AEIER).

ALARM AND ERROR INTERRUPT ENABLE REGISTER (AEIER) (ADDRESS = 0X0B03H)

BIT NUMBER	BIT NAME	BIT TYPE	BIT DESCRIPTION
3	Receive Bipolar Violation Interrupt Enable	R/W	0 - The Receive Bipolar Violation interrupt is disabled. Occurrence of one or more bipolar violations will not generate an interrupt. 1 - The Receive Bipolar Violation interrupt is enabled. Occurrence of one or more bipolar violations will generate an interrupt.

The table below shows configurations of the Alarm and Error Interrupt Enable bit of the Block Interrupt Enable Register.

BLOCK INTERRUPT ENABLE REGISTER (BIER) (ADDRESS = 0X0B01H)

BIT NUMBER	BIT NAME	BIT TYPE	BIT DESCRIPTION
1	Alarm and Error Interrupt Enable	R/W	0 - Every interrupt generated by the Alarm and Error Interrupt Status Register (AEISR) is disabled. 1 - Every interrupt generated by the Alarm and Error Interrupt Status Register (AEISR) is enabled.

When these interrupt enable bits are set and one or more Bipolar Violations are present in the incoming DS1 frame, the XRT86L30 framer will declare Receive Bipolar Violation by doing the following:

- Set the Receive Bipolar Violation bit of the Alarm and Error Status Register to one indicating there are one or more Bipolar Violations. This status indicator is valid until the Framer Interrupt Status Register is read.

Reading this register clears the associated interrupt if Reset-Upon-Read is selected in Interrupt Control Register (ICR). Otherwise, a write-to-clear operation by the microprocessor is required to reset these status indicators.

The table below shows the Receive Bipolar Violation status bits of the Alarm and Error Status Register.

ALARM AND ERROR STATUS REGISTER (AESR) (ADDRESS = 0X0B02H)

BIT NUMBER	BIT NAME	BIT TYPE	BIT DESCRIPTION
3	Receive Bipolar Violation State Change	RUR / WC	0 - There is no change of Bipolar Violation state in the incoming DS1 payload data. 1 - There is change of Bipolar Violation state in the incoming DS1 payload data.

ALARM AND ERROR INTERRUPT ENABLE REGISTER (AEIER) (ADDRESS = 0X0B03H)

BIT NUMBER	BIT NAME	BIT TYPE	BIT DESCRIPTION
4	Receive Loss of Signal Interrupt Enable	R/W	0 - The Receive Loss of Signal interrupt is disabled. Occurrence of Loss of Signals will not generate an interrupt. 1 - The Receive Loss of Signal interrupt is enabled. Occurrence of Loss of Signals will generate an interrupt.

The table below shows configurations of the Alarm and Error Interrupt Enable bit of the Block Interrupt Enable Register.

BLOCK INTERRUPT ENABLE REGISTER (BIER) (ADDRESS = 0X0B01H)

BIT NUMBER	BIT NAME	BIT TYPE	BIT DESCRIPTION
1	Alarm and Error Interrupt Enable	R/W	0 - Every interrupt generated by the Alarm and Error Interrupt Status Register (AEISR) is disabled. 1 - Every interrupt generated by the Alarm and Error Interrupt Status Register (AEISR) is enabled.

SINGLE T1/E1/J1 FRAMER/LIU COMBO

When these interrupt enable bits are set and one or more Loss of Signals are present in the incoming DS1 frame, the XRT86L30 framer will declare Receive Loss of Signal by doing the following:

- Set the Receive Loss of Signal bit of the Alarm and Error Status Register to one indicating there is one or more Loss of Signals. This status indicator is valid until the Framer Interrupt Status Register is read.

Reading this register clears the associated interrupt if Reset-Upon-Read is selected in Interrupt Control Register (ICR). Otherwise, a write-to-clear operation by the microprocessor is required to reset these status indicators.

The table below shows the Receive Loss of Signal status bits of the Alarm and Error Status Register.

ALARM AND ERROR STATUS REGISTER (AESR) (ADDRESS = 0X0B02H)

BIT NUMBER	BIT NAME	BIT TYPE	BIT DESCRIPTION
4	Receive Loss of Signal State	RUR / WC	0 - There is no change of Loss of Signal state in the incoming DS1 payload data. 1 - There is change of Loss of Signal state in the incoming DS1 payload data.

12.5 E1 Brief discussion of alarms and error conditions

As defined in E1 specification, alarm conditions are created from defects. Defects are momentary impairments present on the E1 trunk. If a defect is present for a sufficient amount of time (called the integration time), then the defect becomes an alarm. Once an alarm is declared, the alarm is present until after the defect clears for a sufficient period of time. The time it takes to clear an alarm is called the de-integration time.

Alarms are used to detect and warn maintenance personnel of problems on the E1 trunk. There are three types of alarms:

- Red alarm or Service Alarm Indication (SAI) Signal
- Blue alarm or Alarm Indication Signal (AIS)
- Yellow alarm or Remote Alarm Indication (RAI) Signal

To explain the error conditions and generation of different alarms, let us create a simple E1 system model. In this model, an E1 signal is sourced from the Central Office (CO) through a Repeater to the Customer Premises Equipment (CPE). At the same time, an E1 signal is routed from the CPE to the Repeater and back to the Central Office. **Figure 97** below shows the simple E1 system model.

FIGURE 97. SIMPLE DIAGRAM OF E1 SYSTEM MODEL

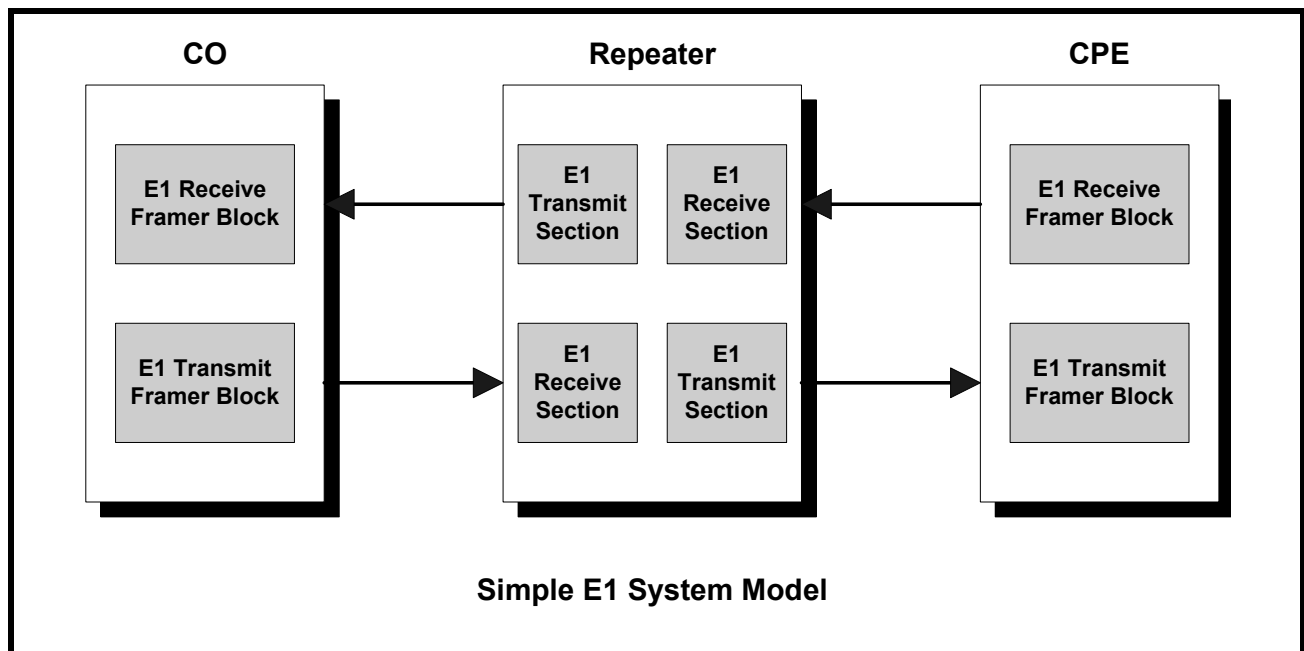

When the E1 system runs normally, that is, when there is no Loss of Signal (LOS) or Loss of Frame (LOF) detected in the line, no alarm will be generated. Sometimes, intermittent outburst of electrical noises on the line might result in Bipolar Violation or bit errors in the incoming signals, but these errors in general will not trigger the equipment to generate alarms. They will, depending on the system requirements, trigger the framer to generate interrupts that would cause the local microprocessor to create performance reports of the line.

Now, consider a case in which the E1 line from the CO to the Repeater is broken or interrupted, resulting in completely loss of incoming data or severely impaired signal quality. Upon detection of Loss of Signal (LOS) or Loss of Frame (LOF) condition, the Repeater will generate an internal Red Alarm, also known as the Service Alarm Indication. This alarm will normally trigger a microprocessor interrupt informing the user that an incoming signal failure is happening.

When the Repeater is in the Red Alarm state, it will transmit the Yellow Alarm to the CO indicating the loss of an incoming signal or loss of frame synchronization. This Yellow Alarm informs the CO that there is a problem

further down the line and its transmission is not being received at the Repeater. **Figure 98** below illustrates the scenario in which the E1 connection from the CO to the Repeater is broken.

FIGURE 98. GENERATION OF YELLOW ALARM BY THE REPEATER UPON DETECTION OF LINE FAILURE

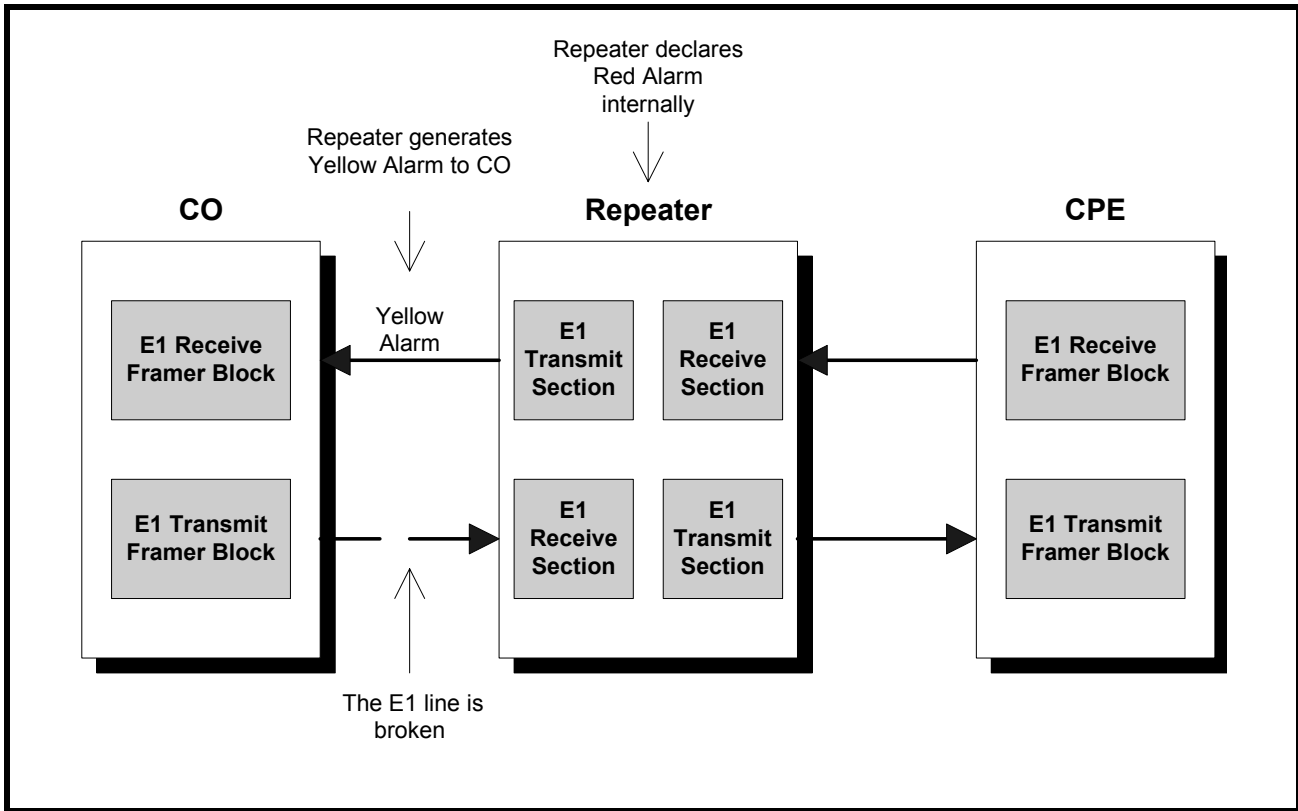

The Repeater will also transmit a Blue Alarm, also known as Alarm Indication Signal (AIS) to the CPE. Blue alarm is an all ones pattern indicating that the equipment is functioning but unable to offer service due to failures originated from remote side. It is sent such that the equipment downstream will not lose clock

synchronization even though no meaningful data is received. **Figure 99** below illustrates this scenario in which the Repeater is sending an AIS to the CPE upon detection of line failure from the CO.

FIGURE 99. GENERATION OF AIS BY THE REPEATER UPON DETECTION OF LINE FAILURE

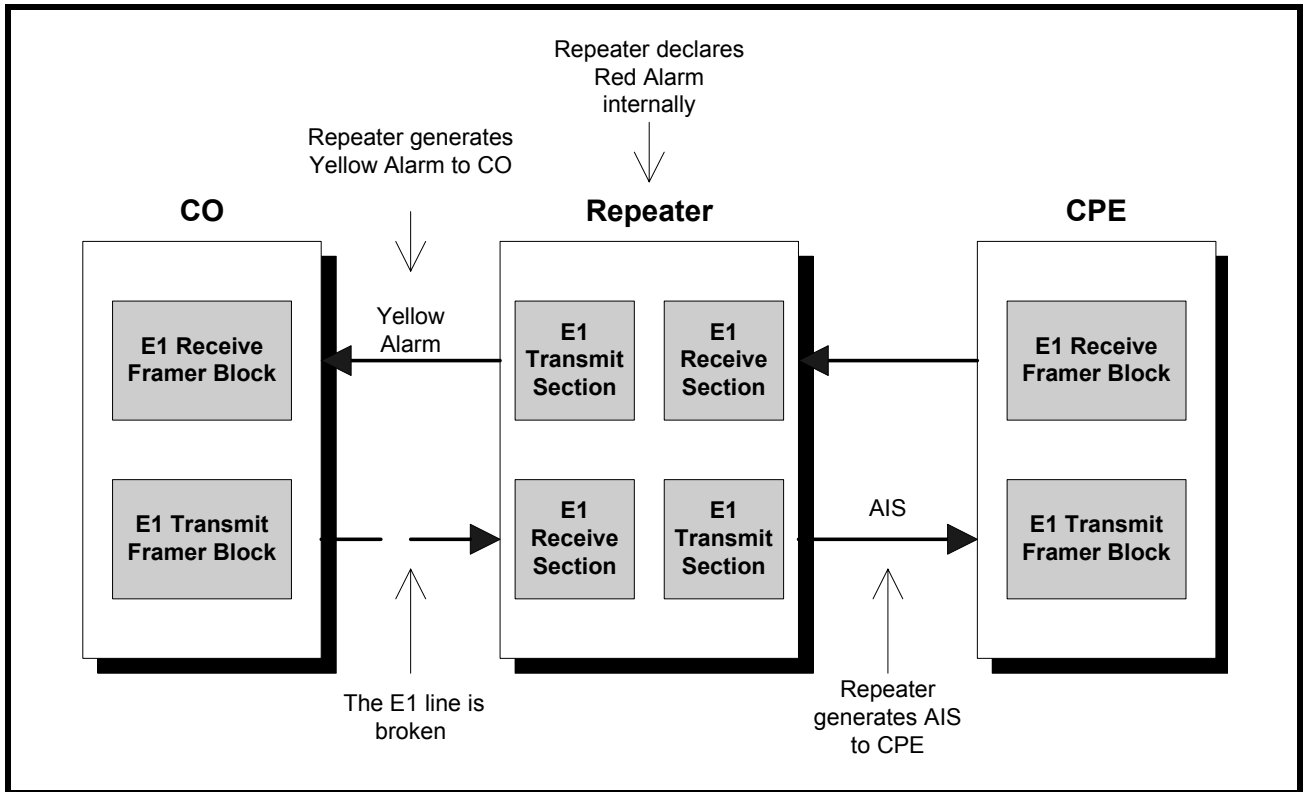

Now, the CPE uses the AIS signal sent by the Repeater to recover received clock and remain in synchronization with the system. Upon detecting the incoming AIS signal, the CPE will generate a Yellow Alarm automatically to the Repeater to indicate the loss of incoming data. **Figure 100** below illustrates this scenario in which the Repeater is sending an AIS to the CPE and the CPE is sending a Yellow Alarm back to the Repeater.

FIGURE 100. GENERATION OF YELLOW ALARM BY THE CPE UPON DETECTION OF AIS ORIGINATED BY THE REPEATER

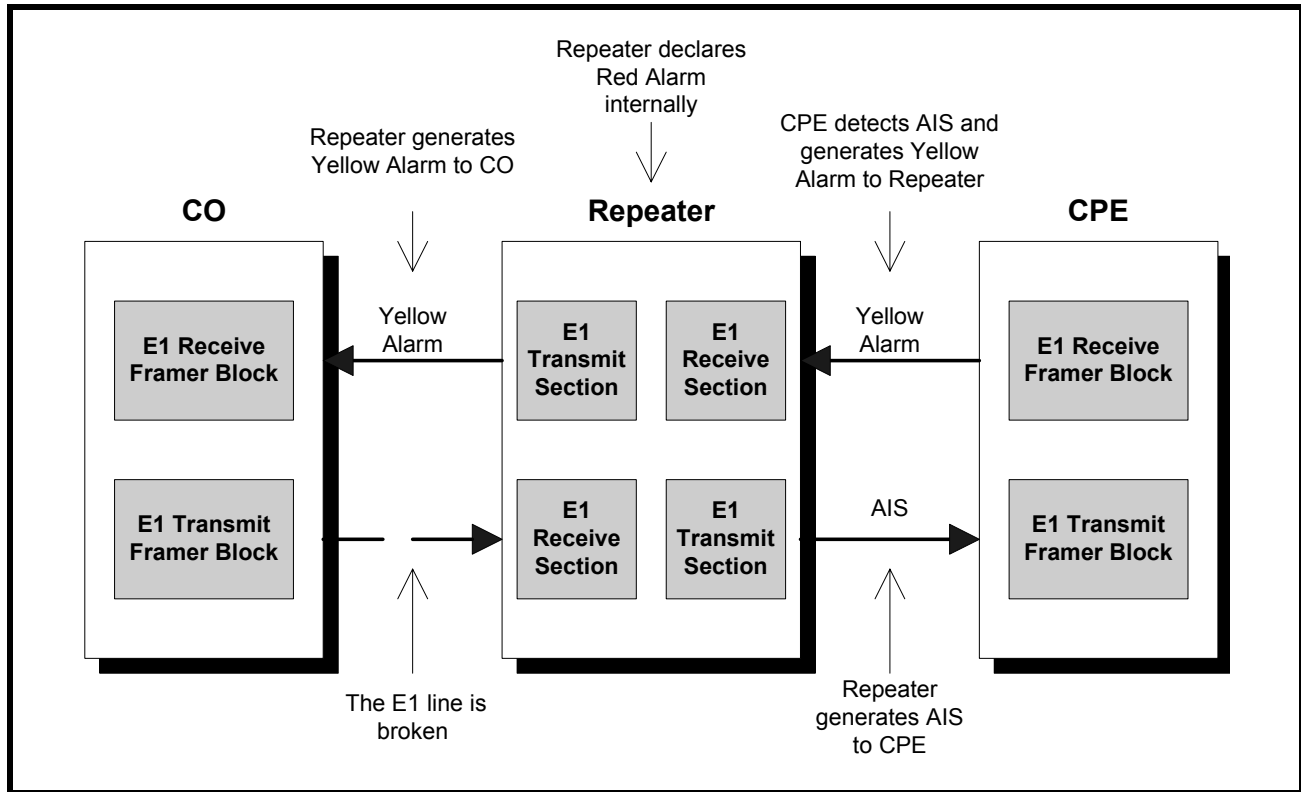

Next, let us consider the scenario in which the signaling and data link channel (the time slot 16) of an E1 line between a far-end terminal (for example, the CO) and a near-end terminal (for example, the repeater) is impaired. In this case, the CAS signaling data received by the repeater is corrupted. The Repeater will then send an all ones pattern in time slot 16 (AIS16) downstream to the CPE. The repeater will also generate a CAS Multi-frame Yellow Alarm upstream to the CO to indicate the loss of CAS Multi-frame synchronization.

Figure 101 below illustrates this scenario in which the Repeater is sending an "AIS16" pattern to the CPE while sending a CAS Multi-frame Yellow Alarm to the CO.

FIGURE 101. GENERATION OF CAS MULTI-FRAME YELLOW ALARM AND AIS16 BY THE REPEATER

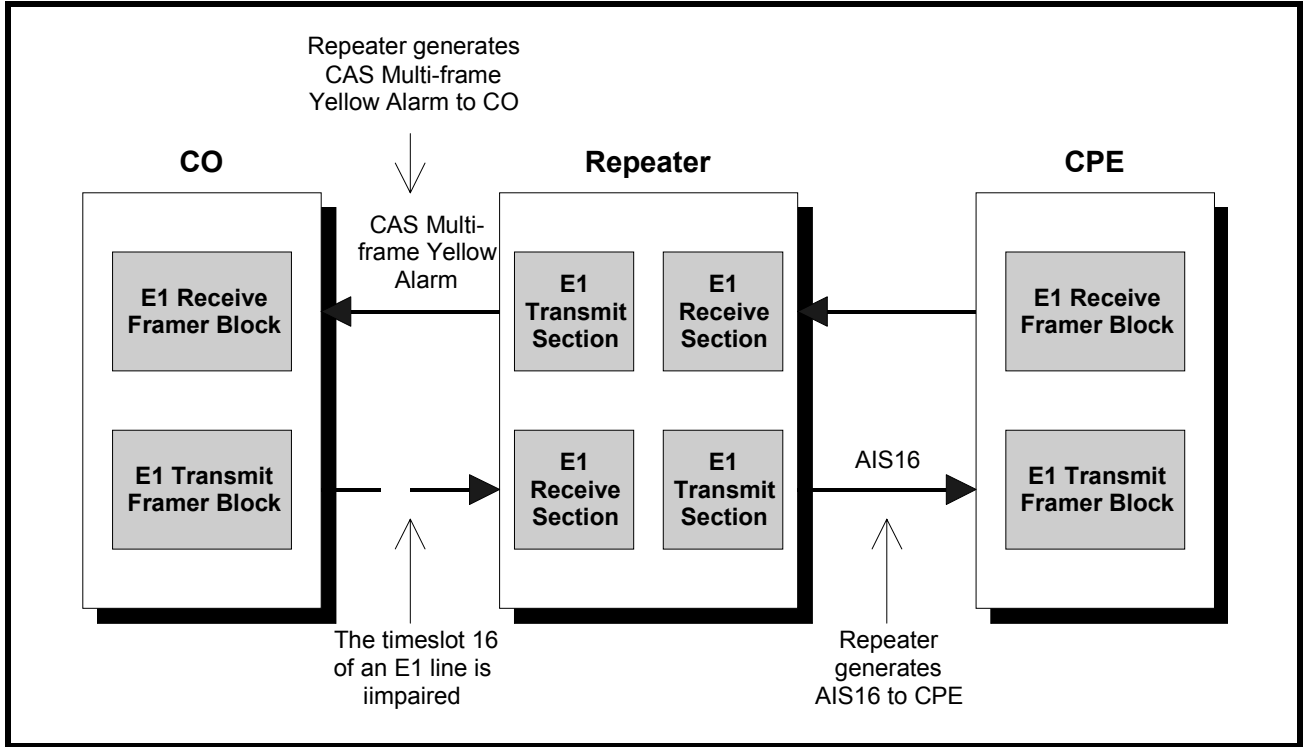

The CPE, upon detecting the incoming AIS16 signal, will generate a CAS Multi-frame Yellow Alarm to the Repeater to indicate the loss of CAS Multi-frame synchronization. **Figure 102** below illustrates the CPE sending a CAS Multi-frame Yellow Alarm back to the Repeater

FIGURE 102. GENERATION OF CAS MULTI-FRAME YELLOW ALARM BY THE CPE UPON DETECTION OF "AIS16" PATTERN SENT BY THE REPEATER

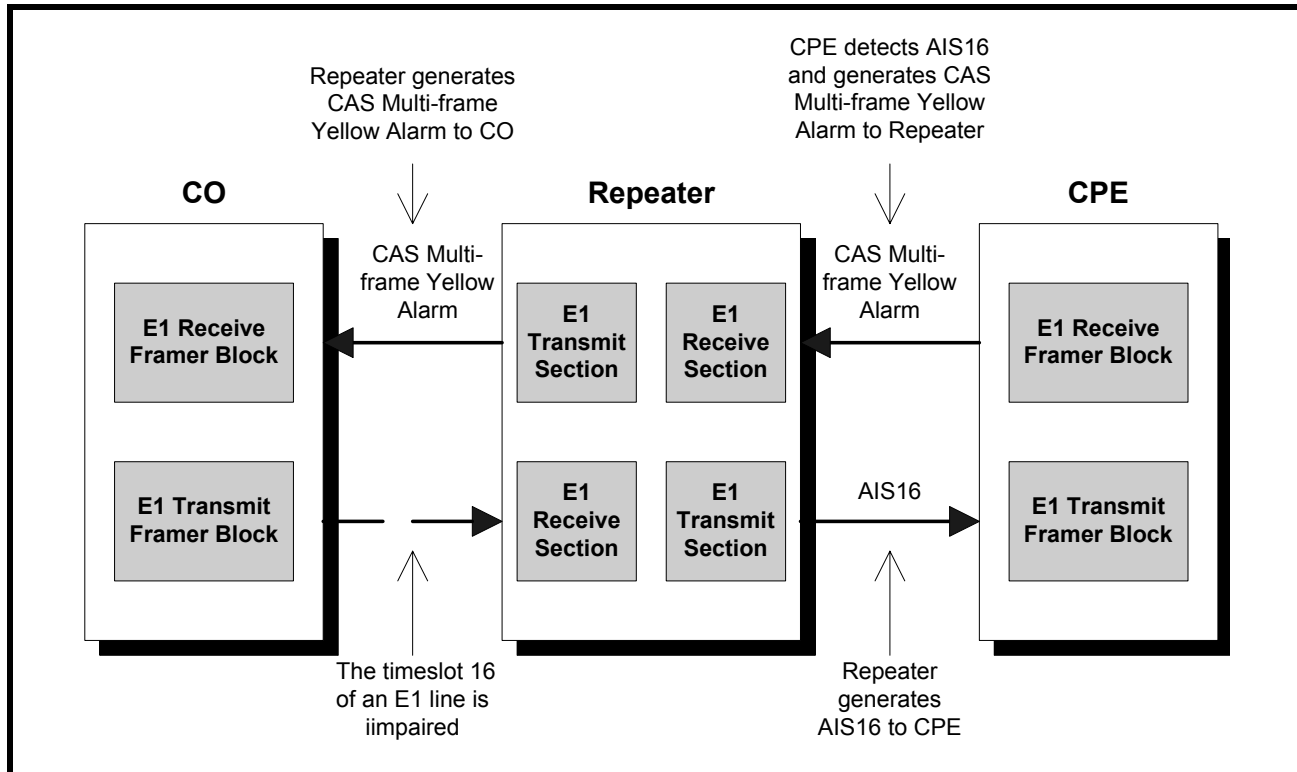

In summary, AIS or Blue Alarm is sent by a piece of E1 equipment downstream indicating that the incoming signal from upstream is lost. Yellow Alarm is sent by a piece of E1 equipment upstream upon detection of Loss of Signal, Loss of Frame or when it is receiving AIS.

Similarly, an "AIS16" pattern is sent by a piece of E1 equipment downstream indicating that the incoming data link channel from upstream is damaged. The CAS Multi-frame Yellow Alarm is sent by a piece of E1 equipment upstream upon detection of Loss of CAS Multi-frame synchronization or when it is receiving an "AIS16" pattern.

12.5.1 How to configure the framer to transmit AIS

As we discussed in the previous section, Alarm Indication Signal (AIS) or Blue Alarm is transmitted by the intermediate node to indicate that the equipment is still functioning but unable to offer services. It is an all ones (except for framing bits) pattern which can be used by the equipment further down the line to maintain clock recovery and timing synchronization.

The XRT86L30 framer can generate three types of AIS when it is running in E1 format:

- Framed AIS
- Unframed AIS
- AIS16

Unframed AIS is an all ones pattern. If unframed AIS is sent, the equipment further down the line will be able to maintain timing synchronization and be able to recover clock from the received AIS signal. However, due to the lack of framing bits, the equipment farther down the line will not be able to maintain frame synchronization and will declare Loss of Frame (LOF).

On the other hand, the payload portion of a framed AIS pattern is all ones. However, a framed AIS pattern still has correct framing bits. Therefore, the equipment further down the line can still maintain frame synchronization as well as timing synchronization. In this case, no LOF or Red alarm will be declared.

"AIS16" is an AIS alarm that is supported only in E1 framing format. It is an all ones pattern in time slot 16 of each E1 frame. As we mentioned before, time slot 16 is usually used for signaling and data link in E1, therefore, an "AIS16" alarm is transmitted by the intermediate node to indicate that the data link channel is having a problem. Since all the other thirty one time slots are still transmitting normal data (that is, framing information and PCM data), the equipment further down the line can still maintain frame synchronization, timing synchronization as well as receive PCM data. In this case, no LOF or Red alarm will be declared by the equipment further down the line. However, a CAS Multi-frame Yellow Alarm will be sent by the equipment further down the line to indicate the loss of CAS Multi-frame alignment.

The Transmit Alarm Indication Signal Select bits of the Alarm Generation Register (AGR) enable the three types of AIS transmission that are supported by the XRT86L30 framer. The table below shows configurations of the Transmit Alarm Indication Signal Select bits of the Alarm Generation Register (AGR).

ALARM GENERATION REGISTER (AGR) (ADDRESS = 0X0108H)

BIT NUMBER	BIT NAME	BIT TYPE	BIT DESCRIPTION
3-2	Transmit AIS Select	R/W	These READ/WRITE bit-fields allows the user to choose which one of the three AIS pattern supported by the XRT86L30 framer will be transmitted. 00 - No AIS alarm is generated. 01 - Enable unframed AIS alarm of all ones pattern. 11 - AIS16 pattern is generated. Only time slot 16 is carrying the all ones pattern. The other time slots still carry framing and PCM data. 11 - Enable framed AIS alarm of all ones pattern except for framing bits.

12.5.2 How to configure the framer to generate Red Alarm

Upon detection of Loss of Signal (LOS) or Loss of Frame (LOF) condition, the Repeater will generate an internal Red Alarm when enabled. This alarm will normally trigger a microprocessor interrupt informing the user that an incoming signal failure is happening.

The Loss of Frame Declaration Enable bit of the Alarm Generation Register (AGR) enable the generation of Red Alarm. The table below shows configurations of the of Frame Declaration Enable bit of the Alarm Generation Register (AGR).

ALARM GENERATION REGISTER (AGR) (ADDRESS = 0X0108H)

BIT NUMBER	BIT NAME	BIT TYPE	BIT DESCRIPTION
6	Loss of Frame Declaration Enable	R/W	This READ/WRITE bit-field permits the framer to declare Red Alarm in case of Loss of Frame Alignment (LOF). When receiver module of the framer detects Loss of Frame Alignment in the incoming data stream, it will generate a Red Alarm. The framer will also generate an RxLOFs interrupt to notify the microprocessor that an LOF condition is occurred. A Yellow Alarm is then returned to the remote transmitter to report that the local receiver detects LOF. 0 - Red Alarm declaration is disabled. 1 - Red Alarm declaration is enabled.

12.5.3 How to configure the framer to transmit Yellow Alarm

The XRT86L30 framer supports transmission of both Yellow Alarm and CAS Multi-frame Yellow Alarm in E1 mode.

Upon detection of Loss of Signal (LOS) or Loss of Frame (LOF) condition, the receiver will transmit the Yellow Alarm back to the source indicating the loss of an incoming signal. This Yellow Alarm informs the source that there is a problem further down the line and its transmission is not being received at the destination.

On the other hand, upon detection of Loss of CAS Multi-frame alignment pattern, the receiver section of the XRT86L30 framer will transmit a CAS Multi-frame Yellow Alarm back to the source indicating the Loss of CAS Multi-frame synchronization.

The Yellow Alarm Generation Select bits of the Alarm Generation Register (AGR) enable transmission of different types of Yellow alarm that are supported by the XRT86L30 framer.

12.5.4 Transmit Yellow Alarm

The Yellow Alarm bits are located at bit 2 of time slot 0 of non-FAS frames. A logic one of this bit denotes the Yellow Alarm and a logic zero of this bit denotes normal operation. The XRT86L30 supports transmission of Yellow Alarm automatically or manually.

When the Yellow Alarm Generation Select bits of the Alarm Generation Register are set to 01, the Yellow Alarm bit is transmitted by echoing the received FAS alignment pattern. If the correct FAS alignment is received, the Yellow Alarm bit is set to zero. If the FAS alignment pattern is missing or corrupted, the Yellow Alarm bit is set to one while Loss of Frame Synchronization is declared.

When the Yellow Alarm Generation Select bits of the Alarm Generation Register are set to 10, the Yellow Alarm bit is transmitted as zero.

When the Yellow Alarm Generation Select bits of the Alarm Generation Register are set to 11, the Yellow Alarm bit is transmitted as one.

12.5.5 Transmit CAS Multi-frame Yellow Alarm

Within the sixteen-frame CAS Multi-frame, the CAS Multi-frame Yellow Alarm bits are located at bit 6 of time slot 16 of frame number 0. A logic one of this bit denotes the CAS Multi-frame Yellow Alarm and a logic zero of this bit denotes normal operation. The XRT86L30 supports transmission of CAS Multi-frame Yellow Alarm automatically or manually.

When the CAS Multi-frame Yellow Alarm Generation Select bits of the Alarm Generation Register are set to 01, the CAS Multi-frame Yellow Alarm bit is transmitted by echoing the received CAS Multi-frame alignment pattern (the four zeros pattern). If the correct CAS Multi-frame alignment is received, the CAS Multi-frame Yellow Alarm bit is set to zero. If the CAS Multi-frame alignment pattern is missing or corrupted, the CAS Multi-frame Yellow Alarm bit is set to one while Loss of CAS Multi-frame Synchronization is declared.

When the CAS Multi-frame Yellow Alarm Generation Select bits of the Alarm Generation Register are set to 10, the CAS Multi-frame Yellow Alarm bit is transmitted as zero.

When the CAS Multi-frame Yellow Alarm Generation Select bits of the Alarm Generation Register are set to 11, the CAS Multi-frame Yellow Alarm bit is transmitted as one.

12.6 T1 Brief discussion of alarms and error conditions

As defined in ANSI T1.231 specification, alarm conditions are created from defects. Defects are momentary impairments present on the DS1 trunk. If a defect is present for a sufficient amount of time (called the integration time), then the defect becomes an alarm. Once an alarm is declared, the alarm is present until after the defect clears for a specified period of time. The time it takes to clear an alarm is called the de-integration time.

Alarms are used to detect and warn maintenance personnel of problems on the DS1 trunk. There are three types of alarms:

- Red alarm or Service Alarm Indication (SAI) Signal
- Blue alarm or Alarm Indication Signal (AIS)
- Yellow alarm or Remote Alarm Indication (RAI) Signal

A simple DS1 system model is shown in **Figure 103** to explain the error conditions and generation of different alarms, let us create. In this model, a DS1 signal is sourced from the Central Office (CO) through a Repeater to the Customer Premises Equipment (CPE). At the same time, a DS1 signal is routed from the CPE to the Repeater and back to the Central Office.

FIGURE 103. SIMPLE DIAGRAM OF DS1 SYSTEM MODEL

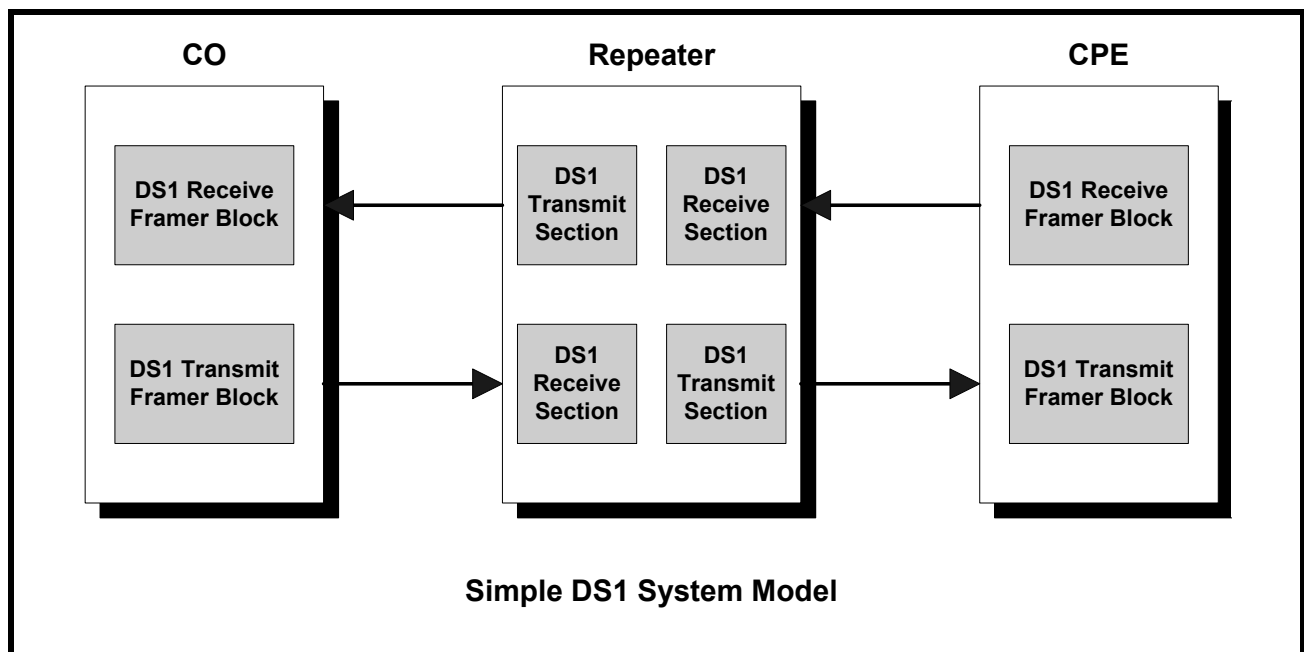

When the DS1 system runs normally, i.e., when there is no Loss of Signal (LOS) or Loss of Frame (LOF) detected in the line, no alarm will be generated. Sometimes, intermittent outburst of electrical noises on the line might result in Bipolar Violation or bit errors in the incoming signals, but these errors in general will not trigger the equipment to generate alarms. They will at most trigger the framer to generate interrupts which would cause the local microprocessor to interrupt as well as add statistics in the performance monitoring accumulator registers.

Now, consider a case in which the DS1 line from the Repeater to CPE is broken or interrupted, resulting in a complete loss of incoming data or a severely impaired signal quality. Upon detection of Loss of Signal (LOS) or Loss of Frame (LOF) condition, the CPE will generate an internal Red Alarm, also known as the Service Alarm Indication. This alarm will normally trigger a microprocessor interrupt informing the user that an incoming signal failure is happening.

When the CPE is in the Red Alarm state, it will transmit the Yellow Alarm to the Repeater indicating the loss of an incoming signal or loss of frame synchronization. This Yellow Alarm informs the Repeater that there is a

problem further down the line and its transmission is not being received at the CPE. The Figure below illustrates the scenario in which the DS1 connection from the Repeater to CPE is broken.

FIGURE 104. GENERATION OF YELLOW ALARM BY THE CPE UPON DETECTION OF LINE FAILURE

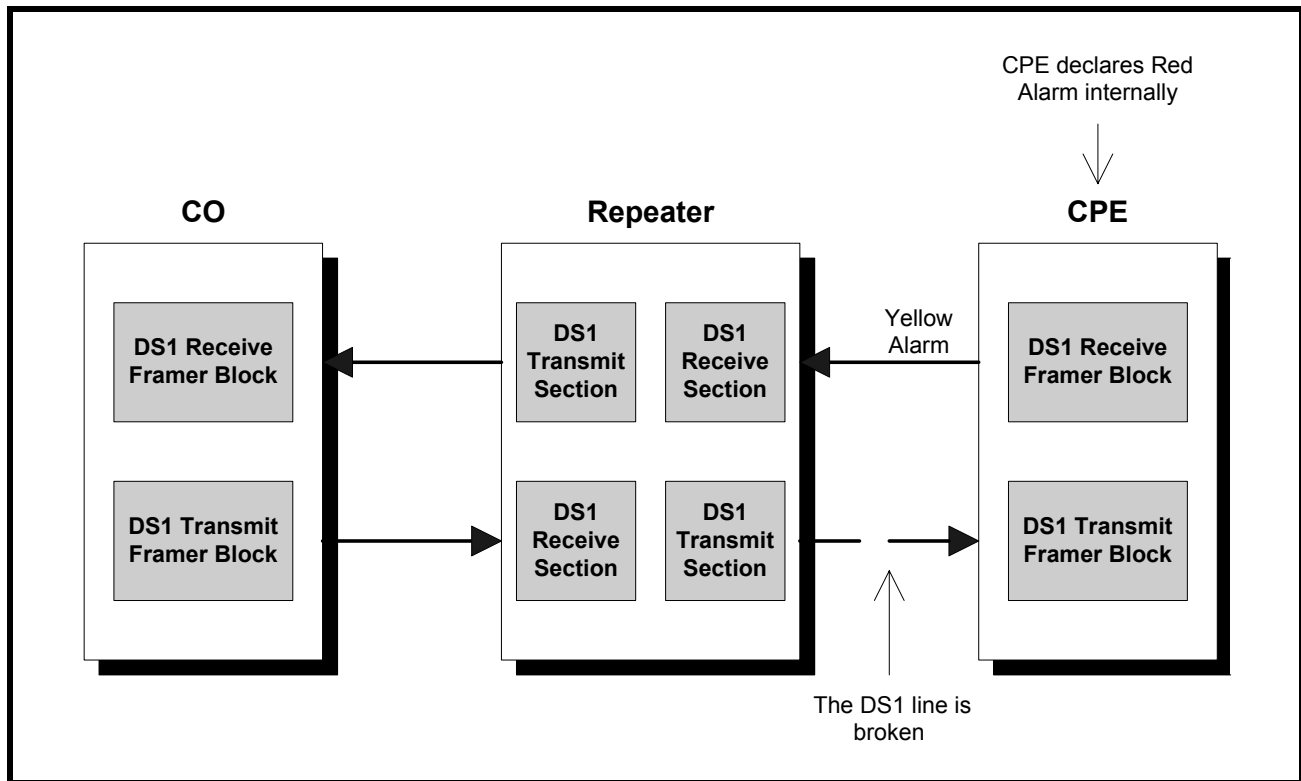

The Repeater, upon detection of Yellow Alarm originated from the CPE, will transmit a Blue Alarm, also known as Alarm Indication Signal (AIS) to the CO. Blue alarm is an all ones pattern indicating that the equipment is functioning but unable to offer service due to failures originated from remote side. It is sent such that the equipment downstream will not lose clock synchronization even though no meaningful data is received. The

Figure below illustrates this scenario in which the Repeater is sending an AIS to CO upon detection of Yellow alarm originated from the CPE.

FIGURE 105. GENERATION OF AIS BY THE REPEATER UPON DETECTION OF YELLOW ALARM ORIGINATED BY THE CPE

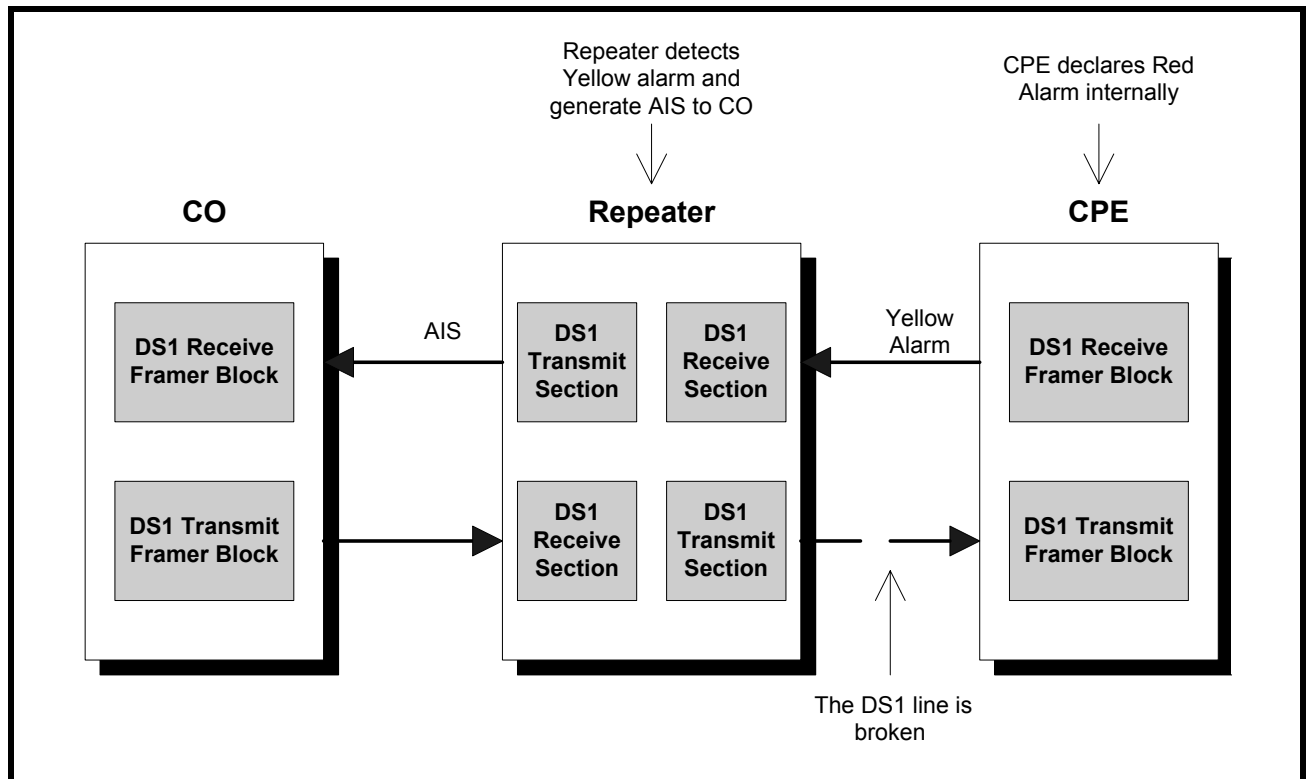

Now let us consider another scenario in which the DS1 line between CO and the Repeater is broken. Again, upon detection of Loss of Signal (LOS) or Loss of Frame (LOF) condition, the Repeater will generate an internal Red Alarm. This alarm will normally trigger a microprocessor interrupt informing the user that an incoming signal failure is happening.

The Repeater will also send an all ones AIS pattern downstream to the CPE and a Yellow Alarm back to the CO. The CPE uses the AIS signal to recover received clock and remain in synchronization with the system. Upon detecting the incoming AIS signal, the CPE will generate a Yellow Alarm to the Repeater to indicate the

loss of incoming signal. The Figure below illustrates this scenario in which the Repeater is sending an AIS to the CPE and the CPE is sending a Yellow Alarm back to the Repeater.

FIGURE 106. GENERATION OF YELLOW ALARM BY THE CPE UPON DETECTION OF AIS ORIGINATED BY THE REPEATER

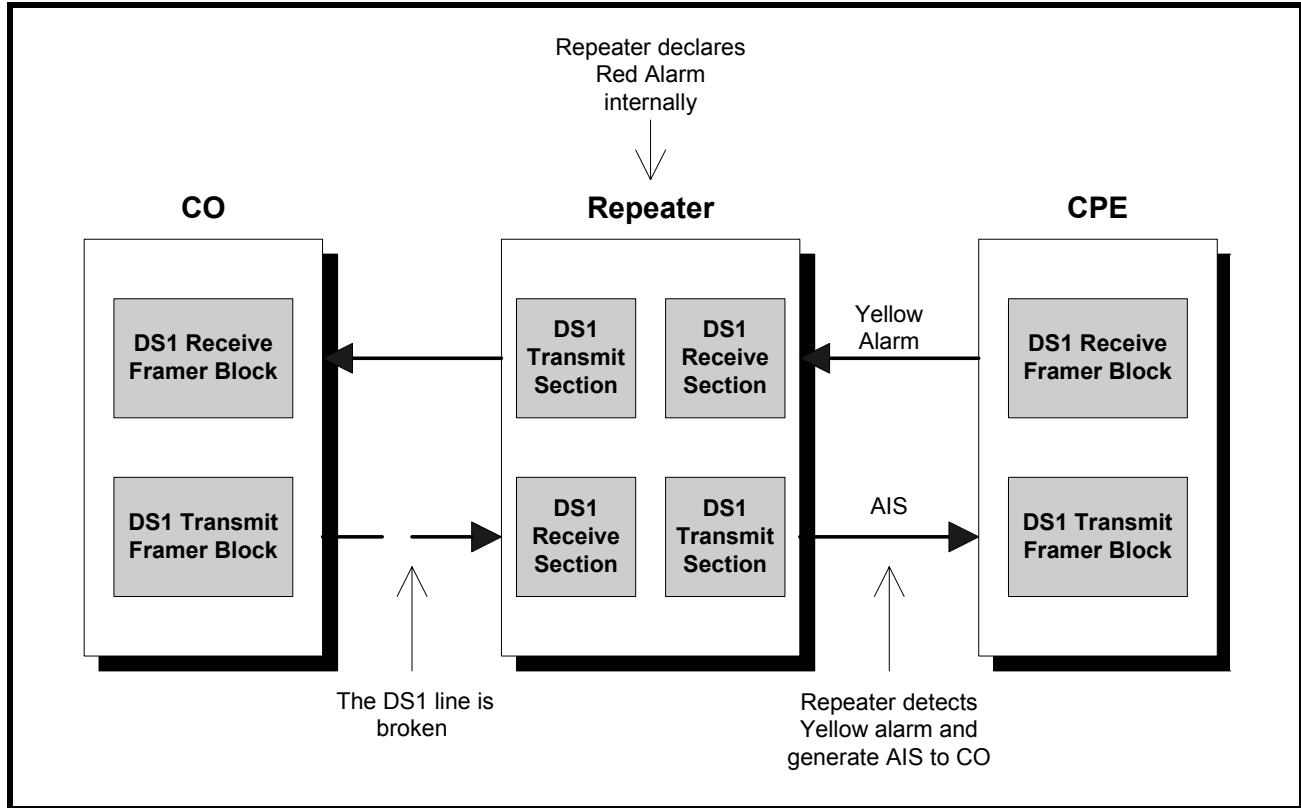

12.6.1 How to configure the framer to transmit AIS

As we discussed in the previous section, Alarm Indication Signal (AIS) or Blue Alarm is transmitted by the intermediate node to indicate that the equipment is still functioning but unable to offer services. It is an all ones (except for framing bits) pattern which can be used by the equipment further down the line to maintain clock recovery and timing synchronization.

The XRT86L30 framer can generate two types of AIS:

- Framed AIS
- Unframed AIS

Unframed AIS is an all ones pattern. If unframed AIS is sent, the equipment further down the line will be able to maintain timing synchronization and be able to recover clock from the received AIS signal. However, due to the lack of framing bits, the equipment farther down the line will not be able to maintain frame synchronization and will declare Loss of Frame (LOF).

On the other hand, the payload portion of a framed AIS pattern is all ones. However, a framed AIS pattern still has correct framing bits. Therefore, the equipment further down the line can still maintain frame synchronization as well as timing synchronization. In this case, no LOF or Red alarm will be declared.

The Transmit Alarm Indication Signal Select bits of the Alarm Generation Register (AGR) enable the two types of AIS transmission that are supported by the XRT86L30 framer. The table below shows configurations of the Transmit Alarm Indication Signal Select bits of the Alarm Generation Register (AGR).

ALARM GENERATION REGISTER (AGR)(ADDRESS = 0X0108H)

BIT NUMBER	BIT NAME	BIT TYPE	BIT DESCRIPTION
3-2	Transmit AIS Select	R/W	These READ/WRITE bit-fields allows the user to choose which one of the two AIS pattern supported by the XRT86L30 framer will be transmitted. 00 - No AIS alarm is generated. 01 - Enable unframed AIS alarm of all ones pattern. 10 - Enable framed AIS alarm of all ones pattern except for framing bits. 11 - No AIS alarm is generated.

12.6.2 How to configure the framer to generate Red Alarm

Upon detection of Loss of Signal (LOS) or Loss of Frame (LOF) condition, the Repeater will generate an internal Red Alarm when enabled. This alarm will normally trigger a microprocessor interrupt informing the user that an incoming signal failure is happening.

The Loss of Frame Declaration Enable bit of the Alarm Generation Register (AGR) enables the generation of Red Alarm. The table below shows configurations of the of Frame Declaration Enable bit of the Alarm Generation Register (AGR).

ALARM GENERATION REGISTER (AGR)(ADDRESS = 0X0108H)

BIT NUMBER	BIT NAME	BIT TYPE	BIT DESCRIPTION
6	Loss of Frame Declaration Enable	R/W	This READ/WRITE bit-field permits the framer to declare Red Alarm in case of Loss of Frame Alignment (LOF). When receiver module of the framer detects Loss of Frame Alignment in the incoming data stream, it will generate a Red Alarm. The framer will also generate an RxLOFs interrupt to notify the microprocessor that an LOF condition is occurred. A Yellow Alarm is then returned to the remote transmitter to report that the local receiver detects LOF. 0 - Red Alarm declaration is disabled. 1 - Red Alarm declaration is enabled.

12.6.3 How to configure the framer to transmit Yellow Alarm

Upon detection of Loss of Signal (LOS) or Loss of Frame (LOF) condition, the receiver will transmit the Yellow Alarm back to the source indicating the loss of an incoming signal. This Yellow Alarm informs the source that there is a problem further down the line and its transmission is not being received at the destination.

The XRT86L30 framer supports transmission of Yellow Alarm when running at the following framing formats:

- SF Mode
- ESF Mode
- N Mode
- T1DM Mode

Yellow alarm is transmitted in different forms for various framing formats. The Yellow Alarm Generation Select bits of the Alarm Generation Register (AGR) enable transmission of different types of Yellow alarm that are supported by the XRT86L30 framer.

12.6.4 Transmit Yellow Alarm in SF Mode

In SF mode, the XRT86L30 supports transmission of Yellow Alarm in two ways. When the Yellow Alarm Generation Select bits of the Alarm Generation Register are set to 01 or 11, the second MSB of all DS0 channels is transmitted as zero. This is Yellow Alarm for DS1 standard.

When the Yellow Alarm Generation Select bits of the Alarm Generation Register are set to 10, the Framing bit of Frame 12 is transmitted as one. This is Yellow Alarm for J1 standard.

12.6.5 Transmit Yellow Alarm in ESF Mode

In ESF mode, the XRT86L30 transmits Yellow Alarm on the 4Kbit/s data link channel. The Facility Data Link bits are sent in the pattern of eight ones followed by eight zeros. The number of repetitions of this pattern depends on the duration of Yellow Alarm Generation Select bits of the Alarm Generation Register. When these select bits are set to 01 or 11, the following scenario will happen:

1. If Bit 0 of Yellow Alarm Generation Select forms a pulse width shorter or equal to the time required to transmit 255 patterns on the 4Kbit/s data link, the alarm is transmitted for 255 patterns.
2. If Bit 0 of Yellow Alarm Generation Select forms a pulse width longer than the time required to transmit 255 patterns on the 4Kbit/s data link, the alarm continues until Bit 0 goes LOW.
3. A second pulse on Bit 0 of Yellow Alarm Generation Select during an alarm transmission resets the pattern counter. The framer will send another 255 patterns of the Yellow Alarm.

NOTE: To pulse Bit 0, this bit must be programmed to "1" and then reset back to "0". The pulse width is the duration in time that this bit remains at "1".

When these select bits are set to 10, Bit 1 of the Yellow Alarm Generation Select forms a pulse that controls the duration of Yellow Alarm transmission. The alarm continues until Bit 1 goes LOW.

When these select bits are set to 01, the following scenario will happen:

1. If Bit 0 of Yellow Alarm Generation Select forms a pulse width shorter or equal to the time required to transmit 255 patterns on the 4Kbit/s data link, the alarm is transmitted for 255 patterns.
2. If Bit 0 of Yellow Alarm Generation Select forms a pulse width longer than the time required to transmit 255 patterns on the 4Kbit/s data link, the alarm continues until Bit 0 goes LOW.
3. A second pulse on Bit 0 of Yellow Alarm Generation Select during an alarm transmission resets the pattern counter. The framer will send another 255 patterns of the Yellow Alarm.

12.6.6 Transmit Yellow Alarm in N Mode

In N mode, when the Yellow Alarm Generation Select bits of the Alarm Generation Register are set to 01, 10 or 11, the second MSB of all DS0 channels is transmitted as zero.

12.6.7 Transmit Yellow Alarm in T1DM Mode

In T1DM mode, when the Yellow Alarm Generation Select bits of the Alarm Generation Register are set to 01, 10 or 11, the Yellow Alarm bit (the third LSB of Timeslot 23) is set to zero. The table below shows configurations of the Yellow Alarm Generation Select bits of the Alarm Generation Register (AGR).

)

ALARM GENERATION REGISTER (AGR)(ADDRESS = 0X0108H)

BIT NUMBER	BIT NAME	BIT TYPE	BIT DESCRIPTION
5-4	Yellow Alarm Generation Select	R/W	<p>00 - Transmission of Yellow Alarm is disabled.</p> <p>01 - The framer transmits Yellow Alarm by converting the second MSB of all outgoing twenty-four DS0 channel into zero.</p> <p>10 - The framer transmits Yellow Alarm by sending the Super-frame Alignment Bit (Fs) of Frame 12 as one.</p> <p>11 - The framer transmits Yellow Alarm by converting the second MSB of all outgoing twenty-four DS0 channel into zero.</p> <p>N Mode:</p> <p>00 - Transmission of Yellow Alarm is disabled.</p> <p>01, 10 or 11 - The framer transmits Yellow Alarm by converting the second MSB of all outgoing twenty-four DS0 channel into zero.</p> <p>ESF Mode:</p> <p>When the framer is in ESF mode, it transmits Yellow Alarm pattern of eight ones followed by eight zeros (1111_1111_0000_0000) through the 4Kbit/s data link bits.</p> <p>00 - Transmission of Yellow Alarm is disabled.</p> <p>01 - The following scenario will happen:</p> <ol style="list-style-type: none"> 1. If Bit 0 of Yellow Alarm Generation Select forms a pulse width shorter or equal to the time required to transmit 255 patterns on the 4Kbit/s data link, the alarm is transmitted for 255 patterns. 2. If Bit 0 of Yellow Alarm Generation Select forms a pulse width longer than the time required to transmit 255 patterns on the 4Kbit/s data link, the alarm continues until Bit 0 goes LOW. 3. A second pulse on Bit 0 of Yellow Alarm Generation Select during an alarm transmission resets the pattern counter. The framer will send another 255 patterns of the Yellow Alarm. <p>10 - Bit 1 of the Yellow Alarm Generation Select forms a pulse that controls the duration of Yellow Alarm transmission. The alarm continues until Bit 1 goes LOW.</p> <p>11 - The following scenario will happen:</p> <ol style="list-style-type: none"> 1. If Bit 0 of Yellow Alarm Generation Select forms a pulse width shorter or equal to the time required to transmit 255 patterns on the 4Kbit/s data link, the alarm is transmitted for 255 patterns. 2. If Bit 0 of Yellow Alarm Generation Select forms a pulse width longer than the time required to transmit 255 patterns on the 4Kbit/s data link, the alarm continues until Bit 0 goes LOW. 3. A second pulse on Bit 0 of Yellow Alarm Generation Select during an alarm transmission resets the pattern counter. The framer will send another 255 patterns of the Yellow Alarm. <p>T1DM Mode:</p> <p>00 - Transmission of Yellow Alarm is disabled.</p> <p>01, 10 or 11 - The framer transmits Yellow Alarm by setting the Yellow Alarm bit (Y-bit) to zero.</p>

13.0 PERFORMANCE MONITORING (PMON)

The function of Performance Monitoring is designed to accumulate error events like line code (bipolar) violations, parity errors, frame alignment errors, etc. using saturating counters. When an accumulation interval is signaled by a one-second interrupt (if enabled), the current counter value can be accessed by the microprocessor. After a read by the microprocessor, the counters are reset and begin accumulating error events for the next interval. The counters are reset in such a manner that error events during the reset period are not missed.

13.1 Receive Line Code Violation Counter (16-Bit)

A line code violation is any event of pulses that does not comply with B8ZS or HDB3 encoding standards. Line code violations and bi-polar violations cause the LCV counter to increment if this feature is enabled. The MSB is stored in register 0x0900h and the LSB is stored in register 0x0901h.

13.2 16-Bit Receive Frame Alignment Error Counter (16-Bit)

A framing bit error event is defined as a error pattern found in FAS or bit 2 of the non-FAS. This counter is disabled during loss of frame synchronization conditions. It is not disabled during loss of synchronization at either the CAS or CRC-4 multiframe stage. The MSB is stored in register 0x0902h and the LSB is stored in register 0x0903h.

13.3 Receive Severely Errored Frame Counter (8-Bit)

A severely errored frame event is defined as the occurrence of two consecutive errored frame alignment signals that are not responsible for loss of frame alignment. The contents of this register are stored in 0x0904h.

13.4 Receive CRC-6/4 Block Error Counter (16-Bit)

A synchronization bit error event is defined as a CRC-6/4 error received. The counter is disabled during loss of sync at either the Frame/FAS or ESF/CRC4 level, but it will not be disabled if loss of multiframe sync occurs at the CAS level. The MSB is stored in register 0x0905h and the LSB is stored in register 0x0906h.

13.5 Receive Far-End Block Error Counter (16-Bit)

13.6 Receive Slip Counter (8-Bit)

A slip event is defined as a replication or deletion of a T1/E1 frame by the receiving slip buffer. The contents of this register are stored in 0x0909h.

13.7 Receive Loss of Frame Counter (8-Bit)

A LOFC is a count of the number of times a Loss of FAS Frame has been declared. This parameter provides the capability to measure an accumulation of short failure events. The contents of this register are stored in 0x090Ah.

13.8 Receive Change of Frame Alignment Counter (8-Bit)

A COFA is declared when the newly-locked framing is different from the one offered by off-line framer. The contents of this register are stored in 0x090Bh.

13.9 Frame Check Sequence Error Counters 1, 2, and 3 (8-Bit Each)

These counters accumulate the times of occurrence the receive frame check sequence error is detected by the LAPD controllers. The contents for LAPD 1 are stored in register 0x090Ch. The contents for LAPD 2 are stored in register 0x091Ch. The contents for LAPD 3 are stored in register 0x092Ch.

13.10 PRBS Error Counter (16-Bit)

This counter contains the 16-bit PRBS bit error event. The MSB is stored in register 0x090Dh and the LSB is stored in register 0x090Eh.

13.11 Transmit Slip Counter (8-Bit)

A slip event is defined as a replication or deletion of a T1/E1 frame by the transmit slip buffer. The contents of this register are stored in 0x090Fh.

13.12 Excessive Zero Violation Counter (16-Bit)

This register contains the accumulation of the events in which excessive zeros have occurred. This is defined as more than 3-bit for HDB3, more than 7-bits for B8ZS, and more than 15-bits for AMI. The MSB is stored in register 0x0910h and the LSB is stored in register 0x0911h.

14.0 APPENDIX A: DS-1/E1 FRAMING FORMATS

14.1 The E1 Framing Structure

A single E1 frame consists of 256 bits which is created 8000 times per second. This yields a bit-rate of 2.048Mbps. The 256 bits within each E1 frame are grouped into 32 octets or timeslots. These timeslots are numbered from 0 to 31. Each timeslot is 8 bits in length and is transmitted most significant bit first, numbered bit 0. **Figure 107** presents a diagram of a single E1 frame.

FIGURE 107. SINGLE E1 FRAME DIAGRAM

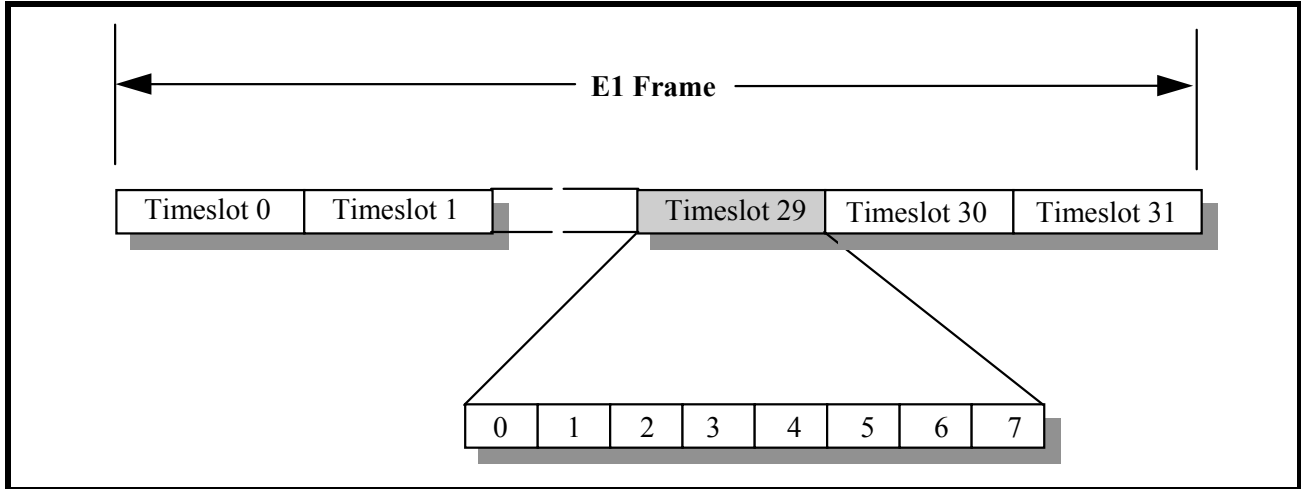

Not all of these timeslots are available to transmit voice or user data. For instance, timeslot 0 is always reserved for system use and timeslot 16 is sometimes used (reserved) by the system. Hence, within each E1 frame, either 30 or 31 of the 32 timeslots are available for transporting user or voice data. In general, there are two types of E1 frames, FAS and Non-FAS. In any E1 data stream, the E1 frame begins with a FAS frame followed by Non-FAS frame and then alternates between the two.

14.1.1 FAS Frame

Timeslot 0 within the FAS E1 frame contains a framing alignment pattern and therefore supports framing. The bit-format of timeslot 0 is presented in **Table 175**. The Si bit within the FAS E1 Frame typically carries the results of a CRC-4 calculation. The fixed framing pattern (e.g., 0, 0, 1, 1, 0, 1, 1) will be used by the Receive E1 Framer at the Remote terminal for frame synchronization/alignment purposes.

TABLE 175: BIT FORMAT OF TIMESLOT 0 OCTET WITHIN A FAS E1 FRAME

BIT	0	1	2	3	4	5	6	7
Value	Si	0	0	1	1	0	1	1
Function	International Bit	Frame Alignment Signaling (FAS) Pattern						
Description-Operation	In practice, the Si bit within the FAS E1 Frame carries the results of a CRC-4 calculation, which is discussed in greater detail in Section 14.2.1.	The fixed framing pattern (e.g., 0, 0, 1, 1, 0, 1, 1) is used by the Receive E1 Framer at the Remote terminal for frame synchronization/alignment purposes.						

14.1.2 Non-FAS Frame

Timeslot 0 within the non-FAS E1 frame contains bits that support signaling or data link message transmission. The bit-format of timeslot 0 is presented in **Table 176**. The Si bit in the Non-FAS frame typically carries a specific value that will be used by the Receive E1 Framer for CRC Multi-frame alignment purposes.

TABLE 176: BIT FORMAT OF TIMESLOT 0 OCTET WITHIN A NON-FAS E1 FRAME

BIT	0	1	2	3	4	5	6	7
Value	Si	1	A	Sa4	Sa5	Sa6	Sa7	Sa8
Function6	International Bit	Fixed Value	Yellow Alarm	National bits				
Description-Operation	International Bit The Si bit within the non-FAS E1 Frame typically carries a specific value that will be used by the Receive E1 Framer for CRC Multi-frame alignment purposes.	Fixed at "1" Bit-field "1" contains a fixed value "1". This bit-field will be used for FAS framing synchronization/alignment purposes by the Remote Receive E1 Framer.	FAS Frame Yellow Alarm Bit This bit-field is used to transmit a Yellow alarm to the Remote Terminal. This bit-field is set to "0" during normal conditions, and is set to "1" whenever the Receive E1 Framer detects an LOS (Loss of Signal) or LOF (Loss of Framing) condition in the incoming E1 frame data.	National Bits These bit-fields can be used to carry data link information from the Local transmitting terminal to the Remote receiving terminal. Since the National bits only exist in the non-FAS frames, they offer a maximum signaling data link bandwidth of 20kbps.				

14.2 The E1 Multi-frame Structure

There are two types of E1 Multi-frame structures, CRC Multi-frame and CAS Multi-frame. The CAS Multi-frame can be considered a subset of the CRC Multi-frame, in that CAS is an option to carry signaling information within the CRC Multi-frame structure.

14.2.1 The CRC Multi-frame Structure

A CRC Multi-frame consists of 16 consecutive E1 frames, with the first of these frames being a FAS frame. From a Frame Alignment point of view, timeslot 0 of each of these E1 frames within the Multi-frame are the most important 16 octets. **Table 177** presents the bit-format for all timeslot 0 octets within a 16 frame CRC Multi-frame.

TABLE 177: BIT FORMAT OF ALL TIMESLOT 0 OCTETS WITHIN A CRC MULTI-FRAME

SMF	FRAME NUMBER	BIT 0	BIT 1	BIT 2	BIT 3	BIT 4	BIT 5	BIT 6	BIT 7
1	0	C1	0	0	1	1	0	1	1
	1	0	1	A	Sa4	Sa5	Sa6	Sa7	Sa8
	2	C2	0	0	1	1	0	1	1
	3	0	1	A	Sa4	Sa5	Sa6	Sa7	Sa8
	4	C3	0	0	1	1	0	1	1
	5	1	1	A	Sa4	Sa5	Sa6	Sa7	Sa8
	6	C4	0	0	1	1	0	1	1
	7	0	1	A	Sa4	Sa5	Sa6	Sa7	Sa8
2	8	C1	0	0	1	1	0	1	1
	9	1	1	A	Sa4	Sa5	Sa6	Sa7	Sa8
	10	C2	0	0	1	1	0	1	1
	11	1	1	A	Sa4	Sa5	Sa6	Sa7	Sa8
	12	C3	0	0	1	1	0	1	1
	13	E	1	A	Sa4	Sa5	Sa6	Sa7	Sa8
	14	C4	0	0	1	1	0	1	1
	15	E	1	A	Sa4	Sa5	Sa6	Sa7	Sa8

The CRC Multi-frame is divided into 2 sub Multi-Frames. Sub-Multi-Frame 1 is designated as SMF1 and Sub-Multi-Frame 2 is designated as SMF2. SMF1 and SMF2 each consist of 8 E1 frames having 4 FAS frames and 4 non-FAS frames. There are two interesting things to note in **Table 177**. First, all of the bit-field 0 positions within each of the FAS frames (within each SMF) are designated as C1, C2, C3 and C4. These four bit-fields contain the CRC-4 values which have been computed over the previous SMF. Hence, while the Transmit E1 Framer is assembling a given SMF, it computes the CRC-4 value for that SMF and inserts these results into the C1 through C4 bit-fields within the very next SMF. These CRC-4 values ultimately are used by the Remote Receive E1 Framer for error detection purposes.

NOTE: This framing structure is referred to as a CRC Multi-Frame because it permits the remote receiving terminal to locate and verify the CRC-4 bit-fields.

The second interesting thing to note regarding **Table 177** is that the bit-field 0 positions within each of the non-FAS frames (within the entire MF) are of a fixed 6-bit pattern 0, 0, 1, 0, 1, 1 along with two bits, each designated as “E”. This 6-bit pattern is referred to as the CRC Multi-Frame alignment pattern, which can

XRT86L30

SINGLE T1/E1/J1 FRAMER/LIU COMBO

ultimately be used by the Remote Receive E1 Framer for CRC Multi-Frame synchronization/alignment. The "E" bits are used to indicate that the Local Receive E1 framer has detected errored sub-Multi-Frames.

14.2.2 CAS Multi-Frames and Channel Associated Signaling

CAS Multi-Frames are only relevant if the user is using CAS or Channel Associated Signaling. If the user is implementing Common Channel Signaling then the CAS Multi-Frame is not available.

14.2.2.1 Channel Associated Signaling

If the user operates an E1 channel in Channel Associated Signaling, then timeslot 16 octets within each E1 frame will be reserved for signaling. Such signaling would convey information such as On-Hook, Off-Hook conditions, call set-up, control, etc. In CAS, this type of signaling data that is associated with a particular voice channel will be carried within timeslot 16 of a particular E1 frame within a CAS Multi-Frame. The CAS is carried in a Multi-Frame structure which consists of 16 consecutive E1 frames. The framing/byte format of a CAS Multi-Frame is presented in **Figure 108**.

FIGURE 108. FRAME/BYTE FORMAT OF THE CAS MULTI-FRAME STRUCTURE

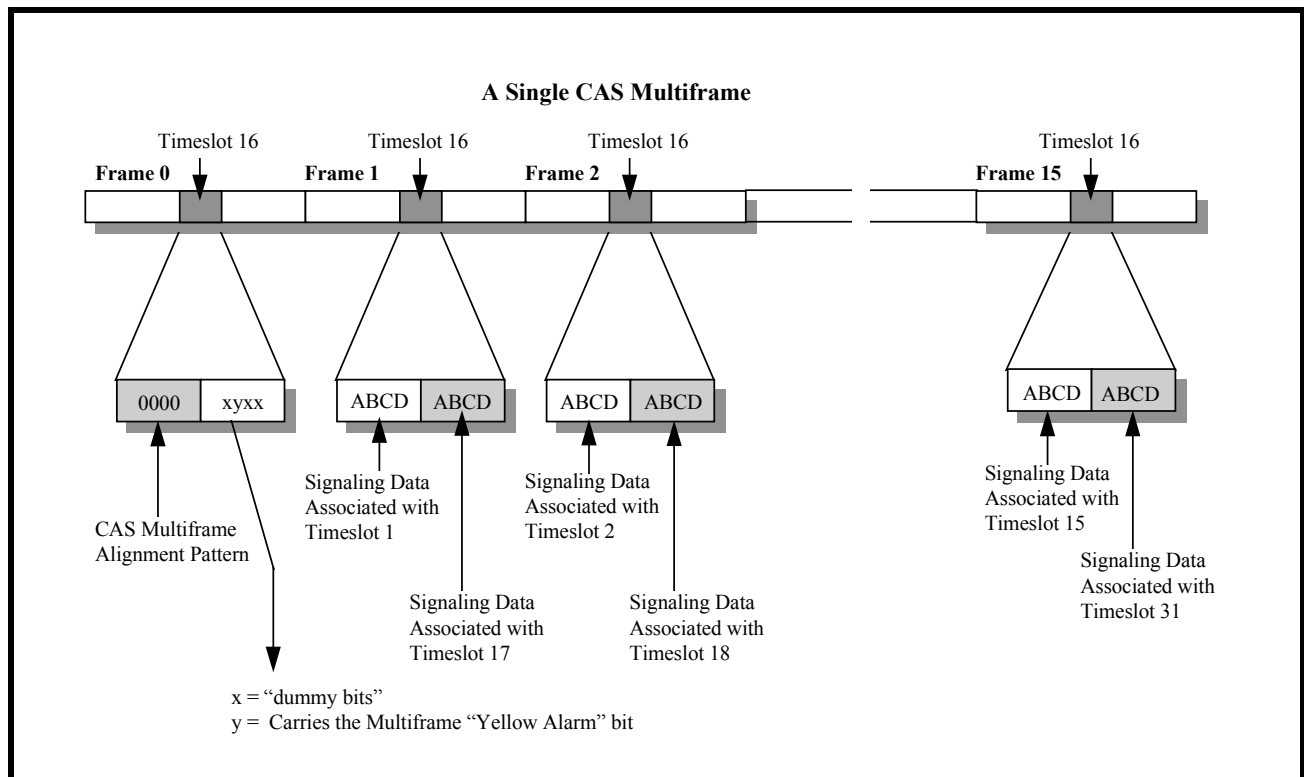

Timeslot 16 within frame 0 is a special octet that is used to convey CAS Multi-Frame alignment information, and to convey Multi-Frame alarm information to the Remote Terminal. The bit-format of timeslot 16 within frame 0 of a CAS Multi-Frame is 0000 xyxx. The upper nibble of this octet contains all zeros and is used to identify itself as the CAS Multi-Frame alignment signal. If CAS is used, then the user is advised to insure that none of the other timeslot 16 octets contain the value "0000". The lower nibble of this octet contains the expression "xyxx". The x-bits are the spare bits and should be set to "0" if not used. The y-bit is used to indicate a Multi-Frame alarm condition to the Remote terminal. During normal operation, this bit-field is cleared to "0". However, if the Local Receive E1 Framer detects a problem with the incoming Multi-Frames, then the Local Transmit E1 Framer will set this bit-field within the next outbound CAS Multi-Frame to "1".

NOTE: The Local Transmit E1 Framer will continue to set the y-bit to "1" for the duration that the Local Receive E1 Framer detects this problem.

Timeslot 16 within Frame 1 of the CAS Multi-Frame contains 4 bits of signaling data for voice channel 1 and 4 bits of signaling data for voice channel 17. Timeslot 16 within Frame 2 contains 4 bits of signaling data for voice channel 2 and 4 bits of signaling data for voice channel 18, and this continues for all E1 frames.

SINGLE T1/E1/J1 FRAMER/LIU COMBO

14.2.2.2 Common Channel Signaling (CCS)

Common Channel Signaling is an alternative form of signaling from CAS. In CCS, whatever signaling data which is transported via the outbound E1 data stream, carries information that applies to all of the voice channels as a set (e.g., timeslots 1 through 15 and 17 through 31) in the E1 frame. There are numerous other variations of Common Channel Signaling that are available. Some of these are listed below.

- 31 Voice Channels with the common channel signaling being transported via the National Bits.
- 30 Voice Channels with the common channel signaling data being transported via the National Bits and CAS data being transported via timeslot 16.
- 30 Voice Channels with the Common Channel Signaling being processed via timeslot 16. (e.g., Primary Rate ISDN Signaling).

FIGURE 109. E1 FRAME FORMAT

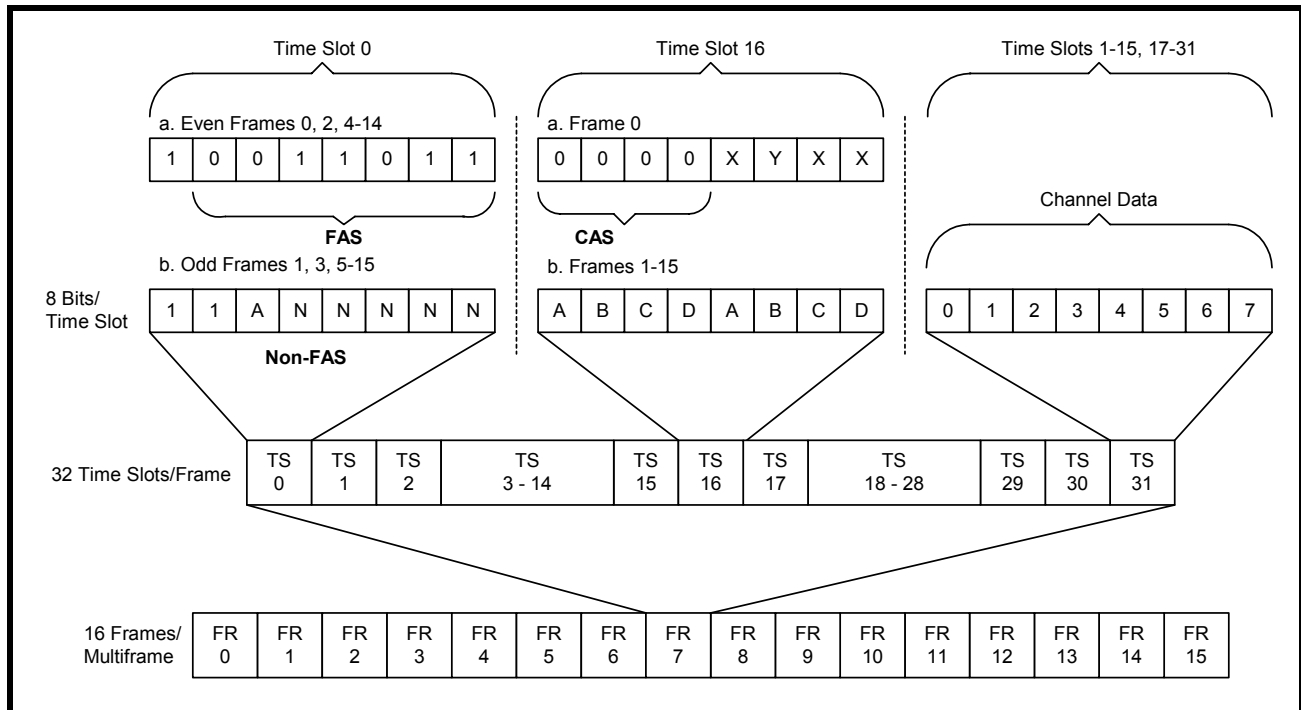

14.3 The DS1 Framing Structure

A single T1 frame is 193 bits long and is transmitted at a frame rate of 8000Hz. This results in an aggregate bit rate of 1.544 Mbit/s. Basic frames are divided into 24 timeslots numbered 1 thru 24 and a framing bit as shown in **Figure 110**. Each timeslot is 8 bits in length and is transmitted most significant bit first, numbered bit 0. This results in a single timeslot data rate of 8 bits x 8000/sec = 64 kbit/s.

FIGURE 110. T1 FRAME FORMAT

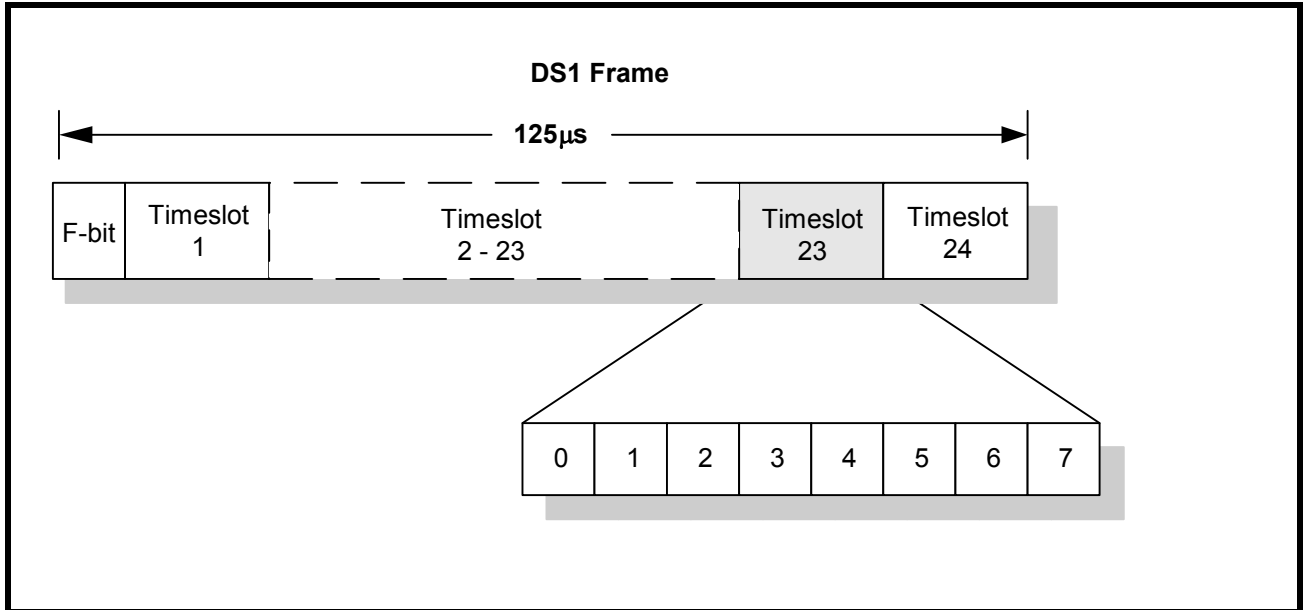

14.4 T1 Super Frame Format (SF)

The Superframe Format (SF), is also referred to as the D4 format. The requirement for associated signaling in frames 6 and 12 dictates that the frames be distinguishable. This leads to a multiframe structure consisting of 12 frames per superframe (SF) as shown in **Figure 111** and **Table 178**. This structure of frames and multiframes is defined by the F-bit pattern. The F-bit is designated alternately as an Ft bit (terminal framing bit) or Fs bit (signalling framing bit). The Ft bit carries a pattern of alternating zeros and ones (101010) in odd frames that defines the boundaries so that one timeslot may be distinguished from another. The Fs bit carries a pattern of (001110) in even frames and defines the multiframe boundaries so that one frame may be distinguished from another.

FIGURE 111. T1 SUPERFRAME PCM FORMAT

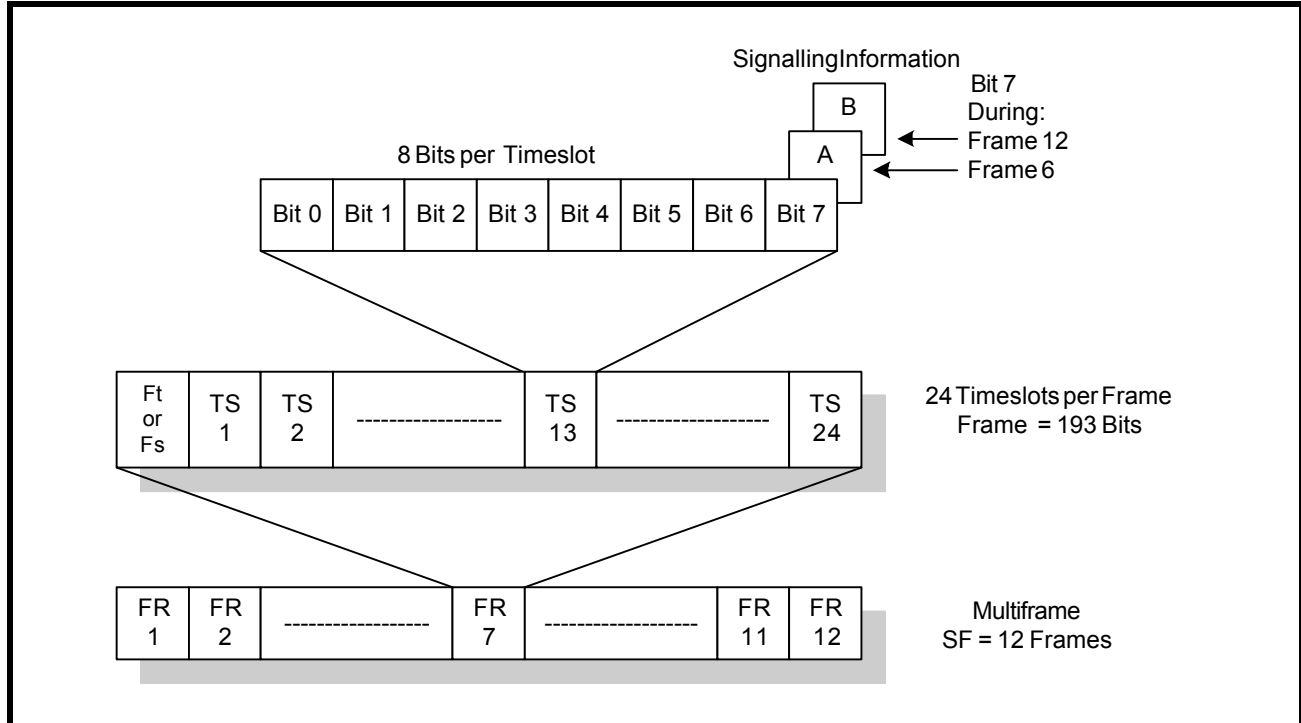

TABLE 178: SUPERFRAME FORMAT

FRAME	BIT	F-BITS		BIT USE IN EACH TIMESLOT		SIGNALLING CHANNEL
		TERMINAL FRAMING Ft	TERMINAL FRAMING Fs	TRAFFIC	SIG	
1	0	1	----	1-8	----	----
2	193	----	0	1-8	----	----
3	386	0	----	1-8	----	----
4	579	----	0	1-8	----	----
5	772	1	----	1-8	----	----
6	965	----	1	1-7	8	A
7	1158	0	----	1-8	----	----
8	1351	----	1	1-8	----	----
9	1544	1	----	1-8	----	----
10	1737	----	1	1-8	----	----
11	1930	0	----	1-8	----	----
12	2123	----	0	1-7	8	B

14.5 T1 Extended Superframe Format (ESF)

In Extended Superframe Format (ESF), as shown in **Figure 112** and **Table 179**, the multiframe structure is extended to 24 frames. The timeslot structure is identical to D4 (SF) format. Robbed-bit signaling is accommodated in frame 6 (A-bit), frame 12 (B-bit), frame 18 (C-bit) and frame 24 (D-bit).

The F-bit pattern of ESF contains three functions:

1. Framing Pattern Sequence (FPS), which defines the frame and multiframe boundaries.
2. Facility Data Link (FDL), which allows data such as error-performance to be passed within the T1 link.
3. Cyclic Redundancy Check (CRC), which allows error performance to be monitored and enhances the reliability of the receiver's framing algorithm.

FIGURE 112. T1 EXTENDED SUPERFRAME FORMAT

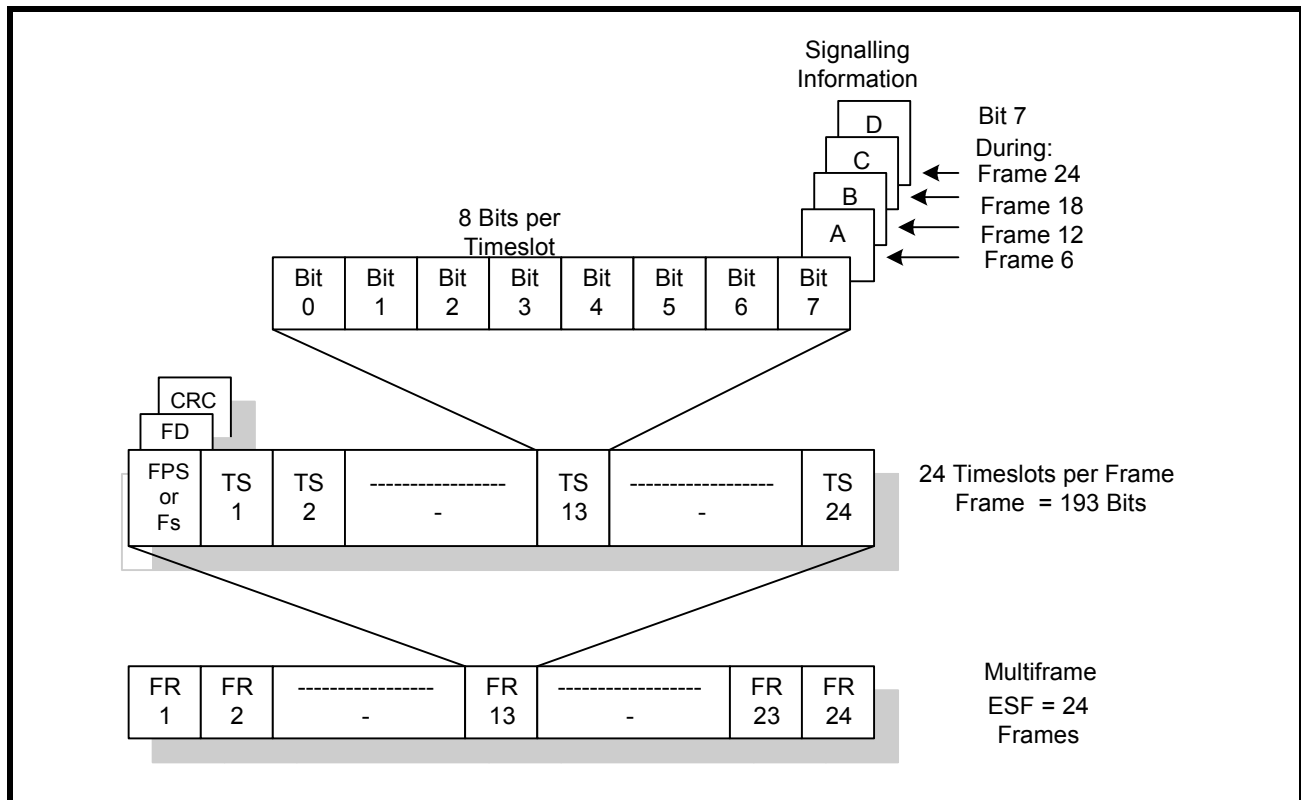

TABLE 179: EXTENDED SUPERFRAME FORMAT

FRAME	BIT	F-BITS			BIT USE IN EACH TIMESLOT		SIGNALLING CHANNEL		
		FPS	DL	CRC	TRAFFIC	SIG	16	4	2
1	0	----	m	----	1-8	----	----	----	----
2	193	----	----	C1	1-8	----	----	----	----
3	386	----	m	----	1-8	----	----	----	----
4	579	0	----	----	1-8	----	----	----	----
5	772	----	m	----	1-8	----	----	----	----
6	965	----	----	C2	1-7	8	A	A	A
7	1158	----	m	----	1-8	----	----	----	----
8	1351	0	----	----	1-8	----	----	----	----
9	1544	----	m	----	1-8	----	----	----	----
10	1737	----	----	C3	1-8	----	----	----	----
11	1930	----	m	----	1-8	----	----	----	----
12	2123	1	----	----	1-7	8	B	B	A
13	2316	----	m	----	1-8	----	----	----	----
14	2509	----	----	C4	1-8	----	----	----	----
15	2702	----	m	----	1-8	----	----	----	----
16	2895	0	----	----	1-8	----	----	----	----
17	3088	----	m	----	1-8	----	----	----	----
18	3281	----	----	C5	1-7	8	C	A	A
19	3474	----	m	----	1-8	----	----	----	----
20	3667	1	----	----	1-8	----	----	----	----
21	3860	----	m	----	1-8	----	----	----	----
22	4053	----	----	C6	1-8	----	----	----	----
23	4246	----	m	----	1-8	----	----	----	----
24	4439	1	----	----	1-7	8	D	B	A

NOTES:

1. *FPS indicates the Framing Pattern Sequence (...001011...)*
2. *DL indicates the 4kb/s Data Link with message bits m.*
3. *CRC indicates the cyclic redundancy check with bits C1 to C6*
4. *Signaling options include 16 state, 4 state and 2 state.*

14.6 T1 Non-Signaling Frame Format

The Non-Signaling (N) framing format is a simplified version of the T1 super frame. The N-Frame consists of four frames with two Fs bits and two Ft bits. The Fs bits can be used as a proprietary 4kbps data link transmission. Signaling is not supported in this framing format.

TABLE 180: NON-SIGNALING FRAMING FORMAT

FRAME	BIT	F-BITS	
		TERMINAL FRAMING Ft	TERMINAL FRAMING Fs
1	0	1	---
2	193	---	X
3	386	0	---
4	579	---	X

14.7 T1 Data Multiplexed Framing Format (T1DM)

T1DM uses a similar framing structure as the SF (D4), such that the Fs and Ft bits on the individual frame boundaries remain the same. The differentiation between T1DM and SF is within the payload time slots. Time slot 24 cannot be used for data when configured for T1DM. Time slot 24 is dedicated for a special synchronization byte as shown in **Figure 113**. The Y-bit is to carry the status of the Yellow Alarm. The R-bit is dedicated for a remote signaling bit typically not used. However, the framer allows this bit to carry an HDLC message. Time slots 1 through 23 are used to carry the seven bit word from each of the 23 DS-0 signals.

FIGURE 113. T1DM FRAME FORMAT

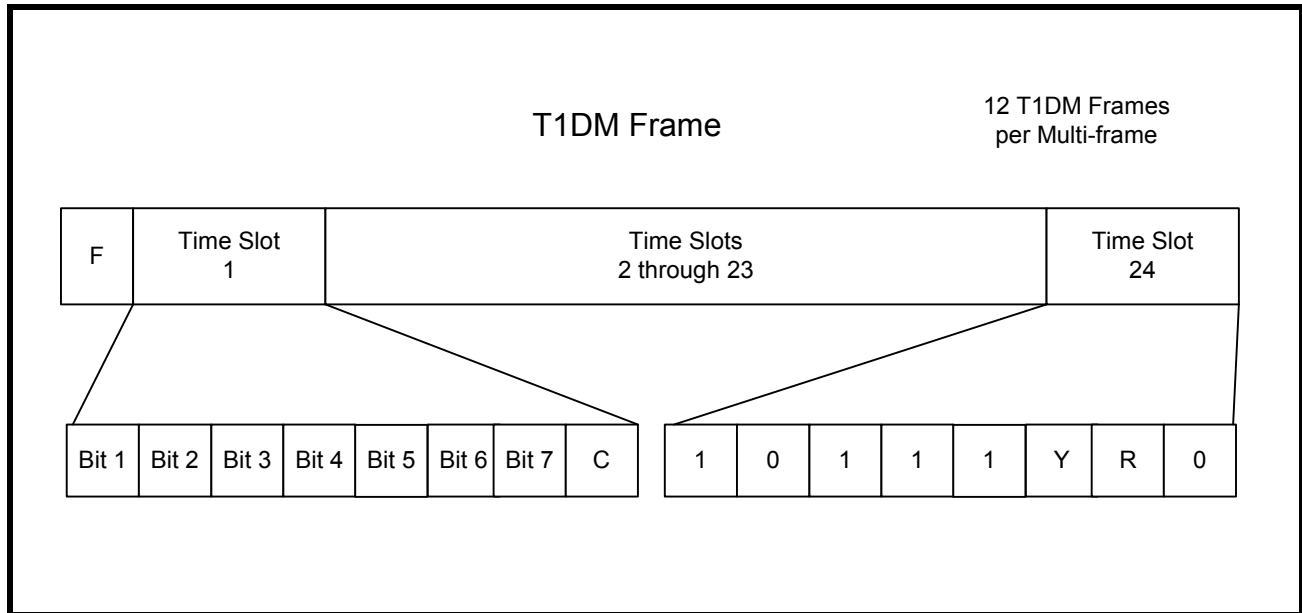

14.8 SLC-96 Format (SLC-96)

SLC framing mode allows synchronization to the SLC®96 data link pattern. This pattern described in Bellcore TR-TSY-000008, contains both signaling information and a framing pattern that overwrites the Fs bit of the SF framer pattern. See **Table 181**.

TABLE 181: SLC®96 Fs BIT CONTENTS

FRAME #	FS BIT	FRAME #	FS BIT	FRAME #	FS BIT
2	0	26	C2	50	0
4	0	28	C3	52	M1
6	1	30	C4	54	M2
8	1	32	C5	56	M3
10	1	34	C6	58	A1
12	0	36	C7	60	A2
14	0	38	C8	62	S1
16	0	40	C9	64	S2
18	1	42	C10	66	S3
20	1	44	C11	68	S4
22	1	46	0	70	1
24	C1	48	1	72	0

NOTES:

1. The SLC®96 frame format is similar to that of SF as shown in **Table 178** with the exceptions shown in this table.
2. C1 to C11 are concentrator bit fields.
3. M1 to M3 are Maintenance bit fields.
4. A1 and A2 are alarm bit fields.
5. S1 to S4 are line switch bit fields.
6. The Fs bits in frames 46, 48 and 70 are spoiler bit switch are used to protect against false multiframing.

ELECTRICAL CHARACTERISTICS

ABSOLUTE MAXIMUMS

Power Supply..... -0.5V to +3.465V	Power Consumption TQFP Package.....726mW
Storage Temperature-65°C to 150°C	Input Logic Signal Voltage (Any Pin)-0.5V to + 5.5V
Operating Temperature Range.....-40°C to 85°C	ESD Protection (HBM).....>2000V
Supply Voltage GND-0.5V to +VDD + 0.5V	Input Current (Any Pin) ± 100mA

DC ELECTRICAL CHARACTERISTICS

Test Conditions: TA = 25°C, VDD = 3.3V ± 5% unless otherwise specified						
SYMBOL	PARAMETER	MIN.	TYP.	MAX.	UNITS	CONDITIONS
I _{LL}	Data Bus Tri-State Bus Leakage Current	-10		+10	µA	
V _{IL}	Input Low voltage			0.8	V	
V _{IH}	Input High Voltage	2.0		VDD	V	
V _{OL}	Output Low Voltage	0.0		0.4	V	I _{OL} = -1.6mA
V _{OH}	Output High Voltage	2.4		VDD	V	I _{OH} = 40µA
I _{OC}	Open Drain Output Leakage Current				µA	
I _{IH}	Input High Voltage Current	-10		10	µA	V _{IH} = VDD
I _{IL}	Input Low Voltage Current	-10		10	µA	V _{IL} = GND

TABLE 182: XRT86L30 POWER CONSUMPTION

VDD=3.3V±5%, T _A =25°C, UNLESS OTHERWISE SPECIFIED									
MODE	SUPPLY VOLTAGE	IMPEDANCE	TERMINATION RESISTOR	TRANSFORMER RATIO		TYP.	MAX.	UNIT	TEST CONDITIONS
				RECEIVER	TRANSMITTER				
E1	3.3V	75Ω	Internal	1:1	1:2	695		mW	PRBS Pattern
E1	3.3V	120Ω	Internal	1:1	1:2	726		mW	PRBS Pattern
T1	3.3V	100Ω	Internal	1:1	1:2	660		mW	PRBS Pattern

AC ELECTRICAL CHARACTERISTICS TRANSMIT FRAMER

Test Conditions: TA = 25°C, VDD = 3.3V ± 5% unless otherwise specified

SYMBOL	PARAMETER	MIN.	TYP.	MAX.	UNITS	CONDITIONS
t ₁	TxMSYNC Setup Time (Falling Edge TxSERCLK)	5			nS	
t ₂	TxMSYNC Hold Time (Falling Edge TxSERCLK)	1			nS	
t ₃	TxSYNC Setup Time (Falling Edge TxSERCLK)	5			nS	
t ₄	TxSYNC Hold Time (Falling Edge TxSERCLK)	1			nS	
t ₅	TxSER Setup Time (Falling Edge TxSERCLK)	5			nS	
t ₆	TxSER Hold Time (Falling Edge TxSERCLK)	1			nS	
t ₇	Rising Edge of TxSERCLK to Rising Edge of TxCHCLK			11	nS	
t ₈	Rising Edge of TxCHCLK to Valid TxCHN[4:0] Data			6	nS	
t ₉	TxSIG Setup Time (Falling Edge TxSERCLK)	5			nS	
t ₁₀	TxSIG Hold Time (Falling Edge TxSERCLK)	1			nS	
t ₁₁	TxFRACT Setup Time (Falling Edge TxSERCLK)	5			nS	
t ₁₂	TxFRACT Hold Time (Falling Edge TxSERCLK)	1			nS	

FIGURE 114. FRAMER SYSTEM TRANSMIT TIMING DIAGRAM

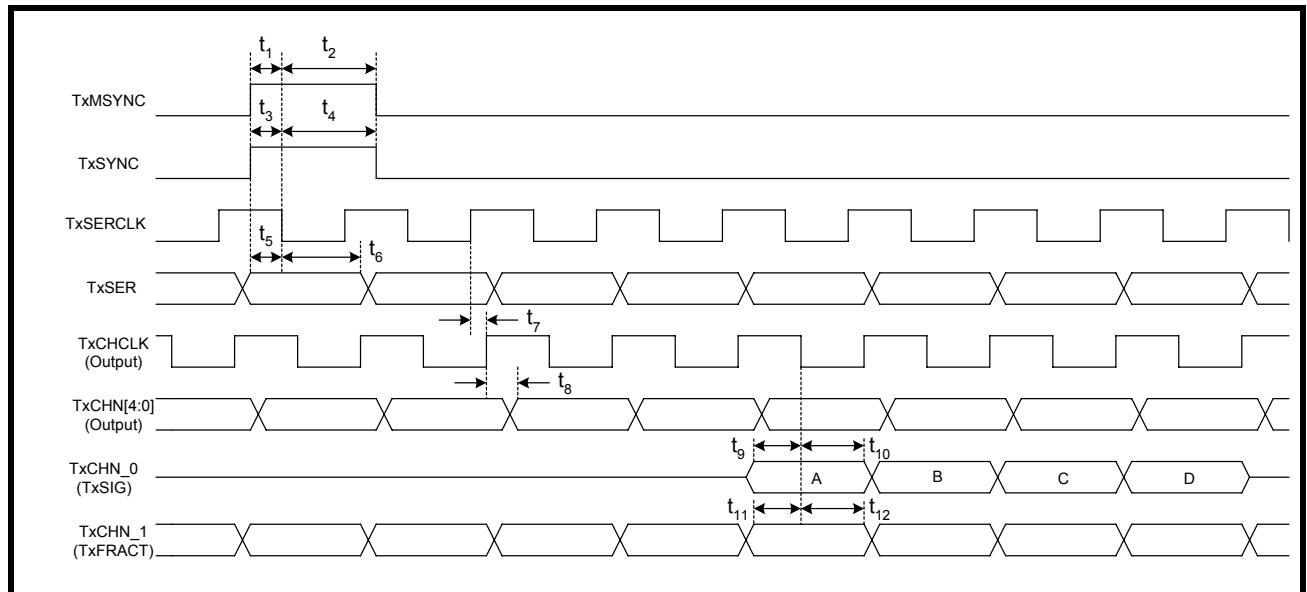

AC ELECTRICAL CHARACTERISTICS RECEIVE FRAMER

Test Conditions: TA = 25°C, VDD = 3.3V ± 5% unless otherwise specified						
SYMBOL	PARAMETER	MIN.	TYP.	MAX.	UNITS	CONDITIONS
RxSERCLK as an Output						
t ₁₃	Rising Edge of RxSERCLK to Rising Edge of RxCASync			4	nS	
t ₁₄	Rising Edge of RxSERCLK to Rising Edge of RxCRCSync			4	nS	
t ₁₅	Rising Edge of RxSERCLK to Rising Edge of RxSYnc			4	nS	
t ₁₆	Rising Edge of RxSERCLK to Rising Edge of RxSER			6	nS	
t ₁₇	Rising Edge of RxSERCLK to Rising Edge of Valid RxCHN[4:0] data			6	nS	
RxSERCLK as an Input						
t ₁₈	Rising Edge of RxSERCLK to Rising Edge of RxCASync			9	nS	
t ₁₉	Rising Edge of RxSERCLK to Rising Edge of RxCRCSync			9	nS	
t ₂₀	Rising Edge of RxSERCLK to Rising Edge of RxSYnc			9	nS	
t ₂₁	Rising Edge of RxSERCLK to Rising Edge of RxSER			11	nS	
t ₂₂	Rising Edge of RxSERCLK to Rising Edge of Valid RxCHN[4:0] data			11	nS	

FIGURE 115. FRAMER SYSTEM RECEIVE TIMING DIAGRAM (RXSERCLK AS AN OUTPUT)

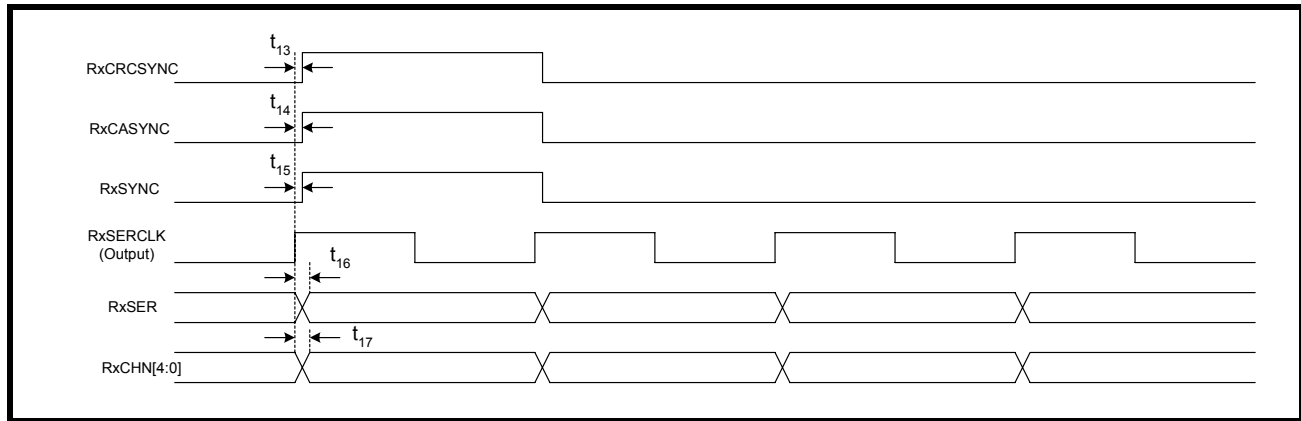
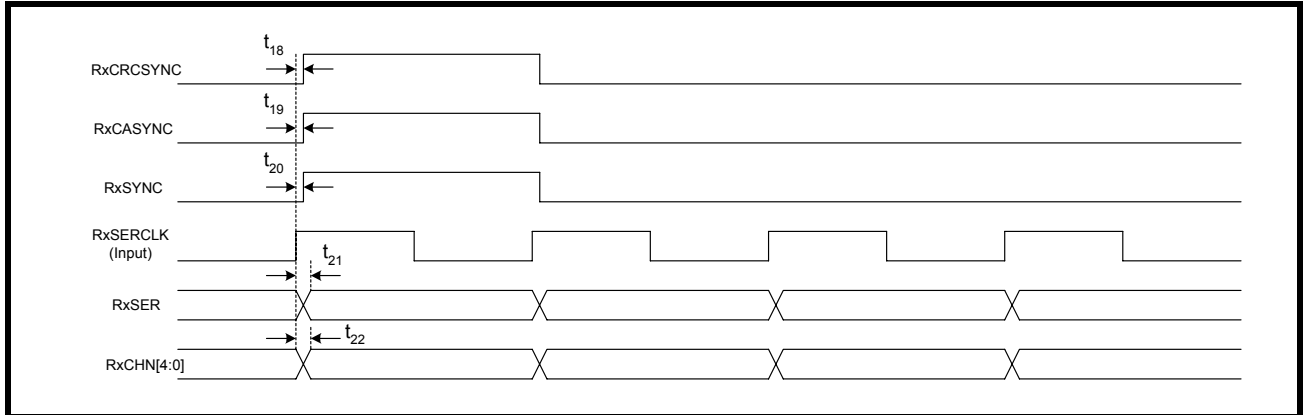

FIGURE 116. FRAMER SYSTEM RECEIVE TIMING DIAGRAM (RxSERCLK AS AN INPUT)



AC ELECTRICAL CHARACTERISTICS TRANSMIT OVERHEAD FRAMER

Test Conditions: TA = 25°C, VDD = 3.3V ± 5% unless otherwise specified

SYMBOL	PARAMETER	MIN.	TYP.	MAX.	UNITS	CONDITIONS
t_{23}	TxSYNC Setup Time (Falling Edge TxSERCLK)	5			nS	
t_{24}	TxSYNC Hold Time (Falling Edge TxSERCLK)	1			nS	
t_{25}	Rising Edge of TxSERCLK to TxOHCLK			11	nS	

FIGURE 117. FRAMER SYSTEM TRANSMIT OVERHEAD TIMING DIAGRAM

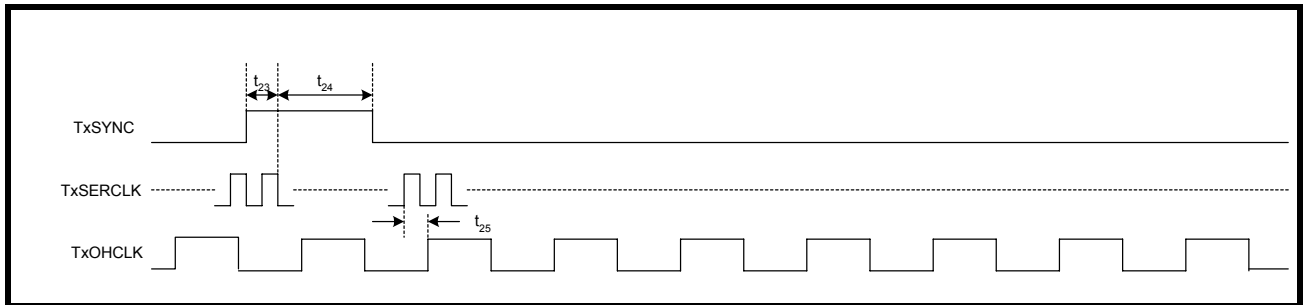

AC ELECTRICAL CHARACTERISTICS RECEIVE OVERHEAD FRAMER

Test Conditions: TA = 25°C, VDD = 3.3V ± 5% unless otherwise specified						
SYMBOL	PARAMETER	MIN.	TYP.	MAX.	UNITS	CONDITIONS
RxSERCLK as an Output						
t ₂₆	Rising Edge of RxSERCLK to Rising Edge of RxSYNC			4	nS	
t ₂₇	Rising Edge of RxSERCLK to Rising Edge of RxO-HCLK			7	nS	
t ₂₈	Rising Edge of RxSERCLK to Rising Edge of RxOH			7	nS	
RxSERCLK as an Input						
t ₂₉	Rising Edge of RxSERCLK to Rising Edge of RxSYNC			9	nS	
t ₃₀	Rising Edge of RxSERCLK to Rising Edge of RxO-HCLK			12	nS	
t ₃₁	Rising Edge of RxSERCLK to Rising Edge of RxOH			12	nS	

FIGURE 118. FRAMER SYSTEM RECEIVE OVERHEAD TIMING DIAGRAM (RxSERCLK AS AN OUTPUT)

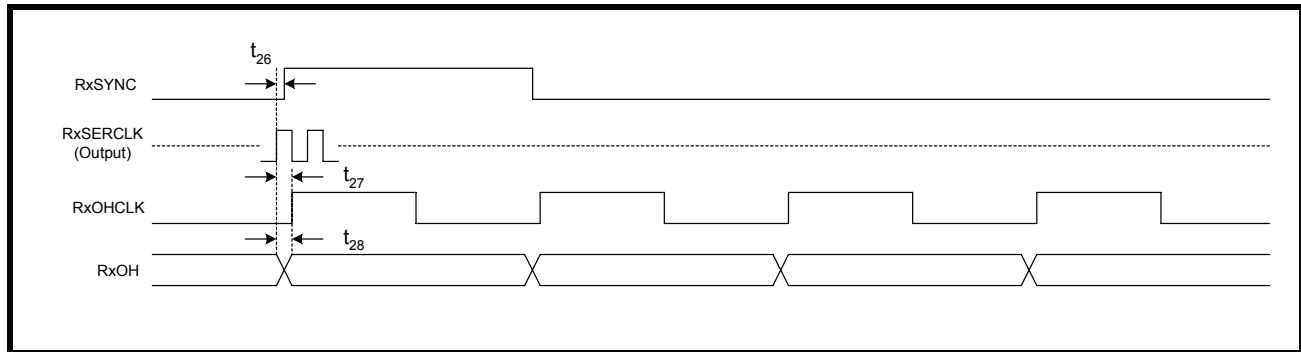
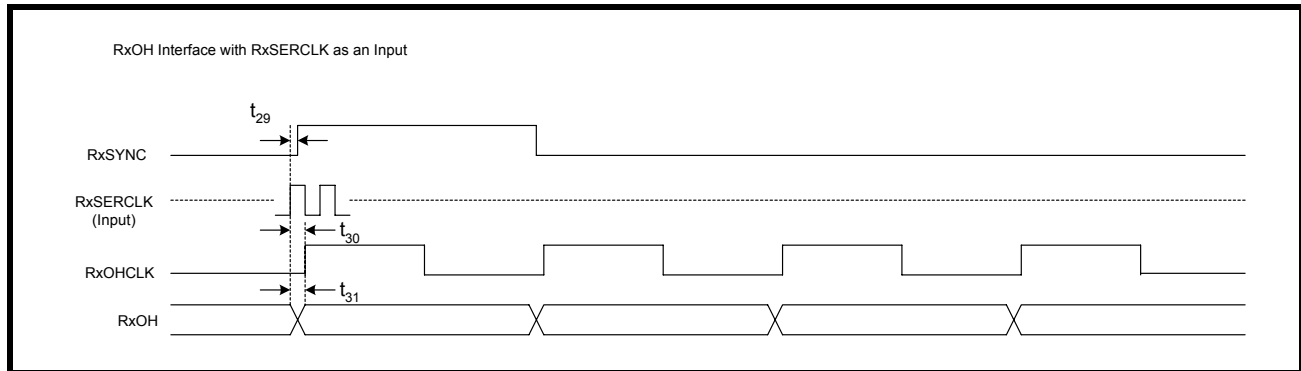

FIGURE 119. FRAMER SYSTEM RECEIVE OVERHEAD TIMING DIAGRAM (RxSERCLK AS AN INPUT)



ELECTRICAL CHARACTERISTICS
TABLE 183: E1 RECEIVER ELECTRICAL CHARACTERISTICS

VDD=3.3V±5%, T _A = -40° TO 85°C, UNLESS OTHERWISE SPECIFIED					
PARAMETER	MIN.	TYP.	MAX.	UNIT	TEST CONDITIONS
Receiver loss of signal: Number of consecutive zeros before RLOS is set		32			Cable attenuation @1024kHz
Input signal level at RLOS	15	20		dB	ITU-G.775, ETSI 300 233
RLOS De-asserted	12.5			% ones	
Receiver Sensitivity (Short Haul with cable loss)	11			dB	With nominal pulse amplitude of 3.0V for 120Ω and 2.37V for 75Ω application. With -18dB interference signal added.
Receiver Sensitivity (Long Haul with cable loss)	0		43	dB	With nominal pulse amplitude of 3.0V for 120Ω and 2.37V for 75Ω application. With -18dB interference signal added.
Input Impedance		13		kΩ	
Input Jitter Tolerance: 1 Hz 10kHz-100kHz	37 0.2			U _{lpp} U _{lpp}	ITU G.823
Recovered Clock Jitter Transfer Corner Frequency Peaking Amplitude	-	36	-0.5	kHz dB	ITU G.736
Jitter Attenuator Corner Frequency (-3dB curve) (JABW=0) (JABW=1)	-	10 1.5	-	Hz Hz	ITU G.736
Return Loss: 51kHz - 102kHz 102kHz - 2048kHz 2048kHz - 3072kHz	14 20 16	-	-	dB dB dB	ITU-G.703

TABLE 184: T1 RECEIVER ELECTRICAL CHARACTERISTICS

VDD=3.3V±5%, T _A =-40° TO 85°C, UNLESS OTHERWISE SPECIFIED					
PARAMETER	MIN.	TYP.	MAX.	UNIT	TEST CONDITIONS
Receiver loss of signal:					
Number of consecutive zeros before RLOS is set	160	175	190		
Input signal level at RLOS	15	20	-	dB	Cable attenuation @772kHz
RLOS Clear	12.5	-	-	% ones	ITU-G.775, ETSI 300 233
Receiver Sensitivity (Short Haul with cable loss)	12	-		dB	With nominal pulse amplitude of 3.0V for 100Ω termination
Receiver Sensitivity (Long Haul with cable loss)		-			With nominal pulse amplitude of 3.0V for 100Ω termination
Normal	0		36	dB	
Extended	0		45	dB	
Input Impedance		13	-	kΩ	
Jitter Tolerance:					
1Hz	138	-	-	UIpp	AT&T Pub 62411
10kHz - 100kHz	0.4	-	-		
Recovered Clock Jitter					
Transfer Corner Frequency	-	9.8	-	KHz	TR-TSY-000499
Peaking Amplitude	-		0.1	dB	
Jitter Attenuator Corner Frequency (-3dB curve)	-	6		-Hz	AT&T Pub 62411
Return Loss:					
51kHz - 102kHz	-	20	-	dB	
102kHz - 2048kHz	-	25	-	dB	
2048kHz - 3072kHz	-	25	-	dB	

TABLE 185: E1 TRANSMIT RETURN LOSS REQUIREMENT

FREQUENCY	RETURN LOSS	
	G.703/CH-PTT	ETS 300166
51-102kHz	8dB	6dB
102-2048kHz	14dB	8dB
2048-3072kHz	10dB	8dB

TABLE 186: E1 TRANSMITTER ELECTRICAL CHARACTERISTICS

VDD=3.3V±5%, T _A =-40° TO 85°C, UNLESS OTHERWISE SPECIFIED					
PARAMETER	MIN.	TYP.	MAX.	UNIT	TEST CONDITIONS
AMI Output Pulse Amplitude:					Transformer with 1:2 ratio and 9.1Ω resistor in series with each end of primary.
75Ω Application	2.13	2.37	2.60	V	
120Ω Application	2.70	3.00	3.30	V	
Output Pulse Width	224	244	264	ns	
Output Pulse Width Ratio	0.95	-	1.05	-	ITU-G.703
Output Pulse Amplitude Ratio	0.95	-	1.05	-	ITU-G.703
Jitter Added by the Transmitter Output	-	0.025	0.05	UIpp	Broad Band with jitter free TCLK applied to the input.
Output Return Loss:					ETSI 300 166, CHPTT
51kHz -102kHz	8	-	-	dB	
102kHz-2048kHz	14	-	-	dB	
2048kHz-3072kHz	10	-	-	dB	

TABLE 187: T1 TRANSMITTER ELECTRICAL CHARACTERISTICS

VDD=3.3V±5%, T _A =-40° TO 85°C, UNLESS OTHERWISE SPECIFIED					
PARAMETER	MIN.	TYP.	MAX.	UNIT	TEST CONDITIONS
AMI Output Pulse Amplitude:	2.4	3.0	3.60	V	Use transformer with 1:2.45 ratio and measured at DSX-1
Output Pulse Width	338	350	362	ns	ANSI T1.102
Output Pulse Width Imbalance	-	-	20	-	ANSI T1.102
Output Pulse Amplitude Imbalance	-	-	±200	mV	ANSI T1.102
Jitter Added by the Transmitter Output	-	0.025	0.05	UIpp	Broad Band with jitter free TCLK applied to the input.
Output Return Loss:					
51kHz -102kHz	-	15	-	dB	
102kHz-2048kHz	-	15	-	dB	
2048kHz-3072kHz	-	15	-	dB	

FIGURE 120. ITU G.703 PULSE TEMPLATE

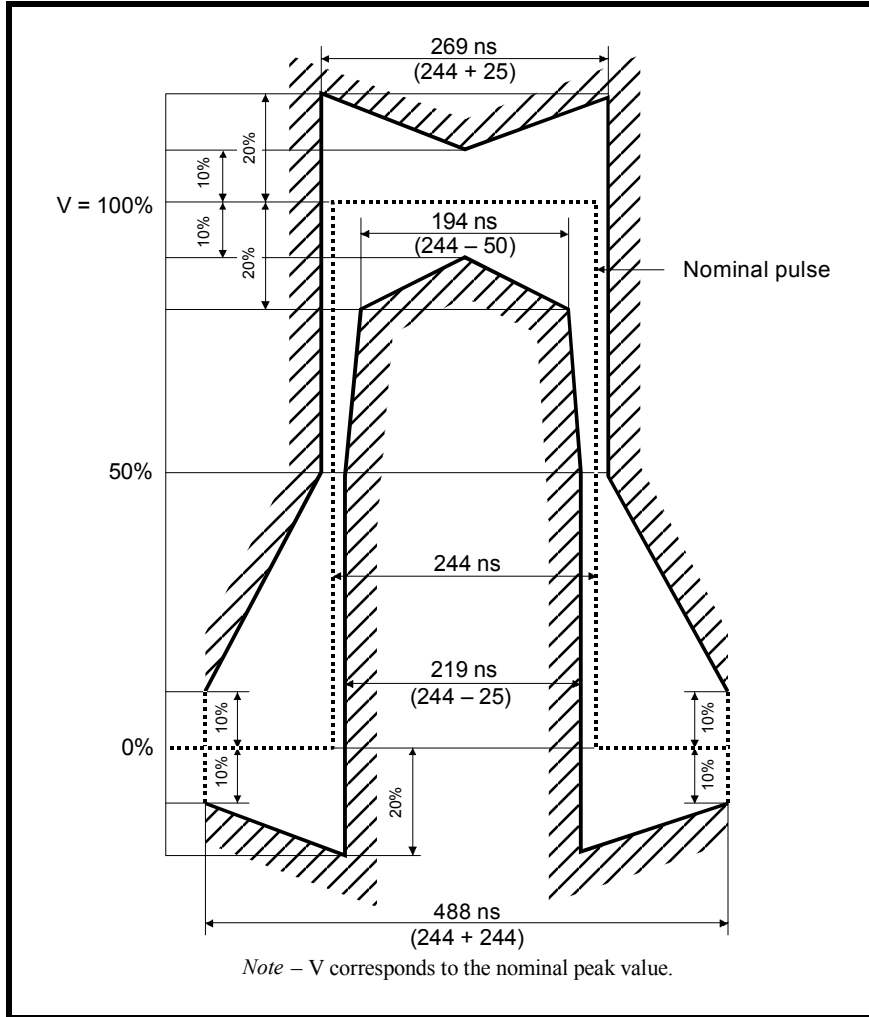

TABLE 188: TRANSMIT PULSE MASK SPECIFICATION

Test Load Impedance	75Ω Resistive (Coax)	120Ω Resistive (twisted Pair)
Nominal Peak Voltage of a Mark	2.37V	3.0V
Peak voltage of a Space (no Mark)	0 ± 0.237V	0 ± 0.3V
Nominal Pulse width	244ns	244ns
Ratio of Positive and Negative Pulses Imbalance	0.95 to 1.05	0.95 to 1.05

FIGURE 121. DSX-1 PULSE TEMPLATE (NORMALIZED AMPLITUDE)

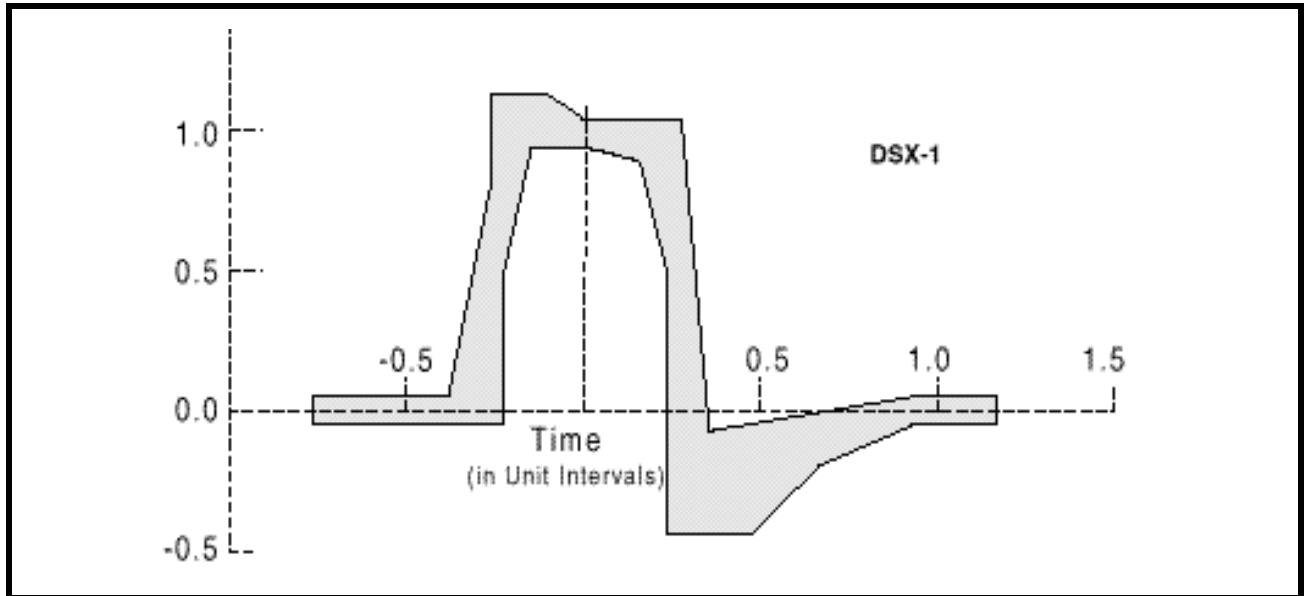

TABLE 189: DSX1 INTERFACE ISOLATED PULSE MASK AND CORNER POINTS

MINIMUM CURVE		MAXIMUM CURVE	
TIME (UI)	NORMALIZED AMPLITUDE	TIME (UI)	NORMALIZED AMPLITUDE
-0.77	-.05V	-0.77	.05V
-0.23	-.05V	-0.39	.05V
-0.23	0.5V	-0.27	.8V
-0.15	0.95V	-0.27	1.15V
0.0	0.95V	-0.12	1.15V
0.15	0.9V	0.0	1.05V
0.23	0.5V	0.27	1.05V
0.23	-0.45V	0.35	-0.07V
0.46	-0.45V	0.93	0.05V
0.66	-0.2V	1.16	0.05V
0.93	-0.05V		
1.16	-0.05V		

TABLE 190: AC ELECTRICAL CHARACTERISTICS

VDD=3.3V±5%, TA=25°C, UNLESS OTHERWISE SPECIFIED					
PARAMETER	SYMBOL	MIN.	TYP.	MAX.	UNITS
MCLKIN Clock Duty Cycle		40	-	60	%
MCLKIN Clock Tolerance		-	±50	-	ppm

XRT86L30

SINGLE T1/E1/J1 FRAMER/LIU COMBO



Experience *Our* Connectivity.

REV. 1.0.0

ORDERING INFORMATION

PART #	PACKAGE	OPERATING TEMPERATURE RANGE
XRT86L30IV	128 Pin TQFP(14x20x1.4mm)	-40 °C to +85 °C

PACKAGE DIMENSIONS

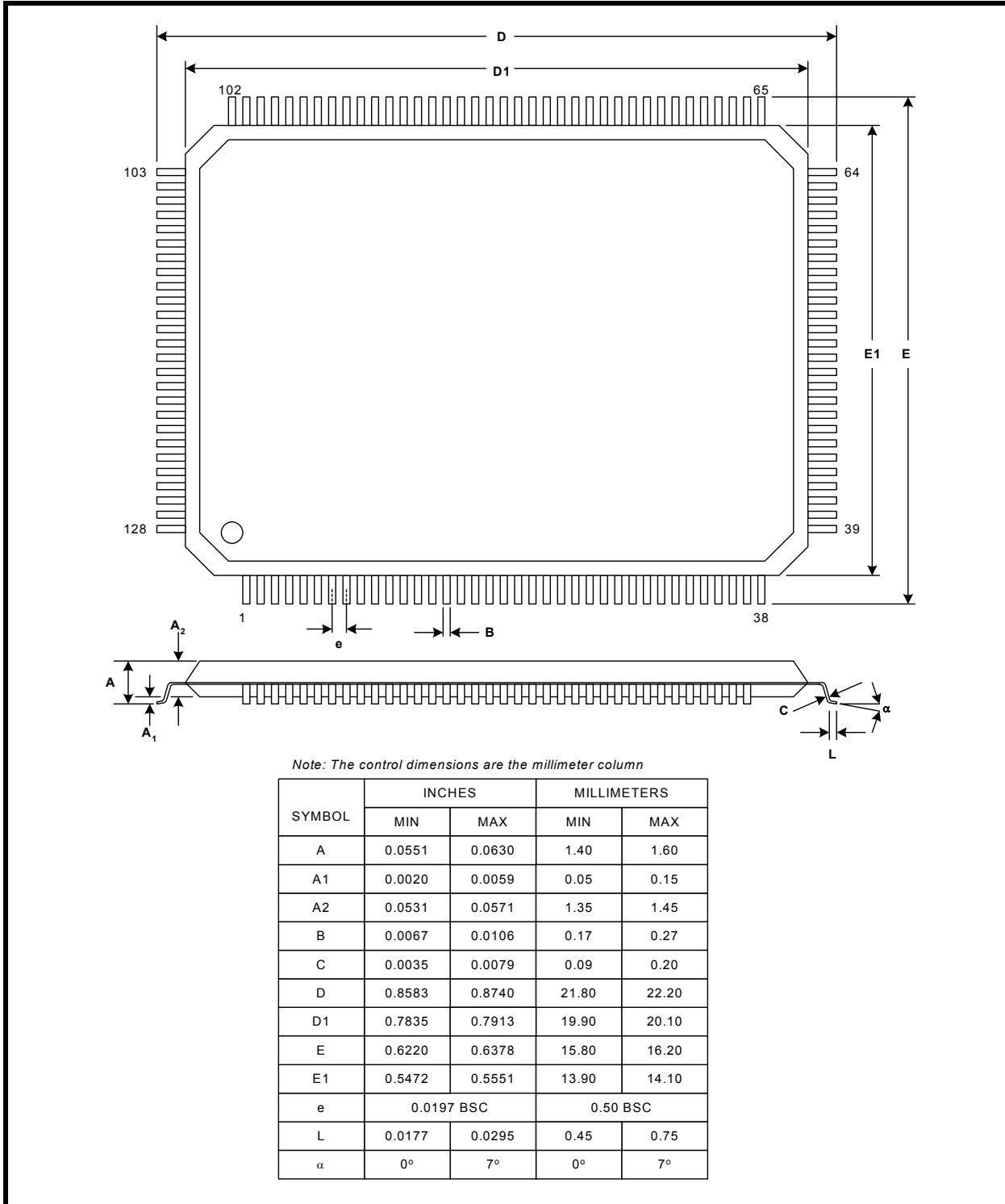

REVISION HISTORY

REVISION #	DATE	DESCRIPTION
P1.0.0	03/26/04	First release of the XRT86L30 preliminary datasheet.
P1.0.1	05/14/04	Added AC Electrical Characteristics. Added Payload Loopback Description.
P1.0.2	06/21/05	Added power consumption numbers.
1.0.0	03/06/07	New logo, removed preliminary for release to production. Changed Ti/E1.403-1955 to T1/E1.403. Changed table 170, signaling channel 4 from ABCB to ABAB and 2 from ABAA to AAAA Corrected RxLOS_n pin description. This pin will be Tri-Stated not pulled "Low" when the Framer or LIU is NOT declaring the LOS defect condition.

NOTICE

EXAR Corporation reserves the right to make changes to the products contained in this publication in order to improve design, performance or reliability. EXAR Corporation assumes no responsibility for the use of any circuits described herein, conveys no license under any patent or other right, and makes no representation that the circuits are free of patent infringement. Charts and schedules contained here in are only for illustration purposes and may vary depending upon a user's specific application. While the information in this publication has been carefully checked; no responsibility, however, is assumed for inaccuracies.

EXAR Corporation does not recommend the use of any of its products in life support applications where the failure or malfunction of the product can reasonably be expected to cause failure of the life support system or to significantly affect its safety or effectiveness. Products are not authorized for use in such applications unless EXAR Corporation receives, in writing, assurances to its satisfaction that: (a) the risk of injury or damage has been minimized; (b) the user assumes all such risks; (c) potential liability of EXAR Corporation is adequately protected under the circumstances.

Copyright 2007 EXAR Corporation

Datasheet March 2007.

Reproduction, in part or whole, without the prior written consent of EXAR Corporation is prohibited.