

Z86C21

8K ROM Z8[®] CMOS MICROCONTROLLER

FEATURES

- 8-Bit CMOS MCU with 8 Kbytes of ROM
- 256 Byte Register File
 - 236 Bytes of General-Purpose RAM
 - 16 Bytes Control/Status Registers
 - 4 Bytes for Ports
- 40-Pin DIP, 44-Pin PLCC or 44-Pin QFP Package
- 4.5V to 5.5V Operating Range
- Low Power Consumption: 220 mW (max) @ 16 MHz
- Fast instruction pointer: 1.0 μ s @ 12 MHz
- Two Standby Modes: STOP and HALT
- 32 Input/Output Lines
- Full-Duplex UART
- All Digital Inputs are TTL Levels
- Auto Latches
- RAM and ROM Protect
- Two Programmable 8-Bit Counter/Timers each with 6-Bit Programmable Prescaler.
- Six Vectored, Priority Interrupts from Eight Different Sources
- Clock Speeds: 12 and 16 MHz
- On-Chip Oscillator that Accepts a Crystal, Ceramic Resonator, LC, or External Clock Drive.

GENERAL DESCRIPTION

The Z86C21 microcontroller is a member of the Z8 single-chip microcontroller family with 8 Kbytes of ROM and 236 bytes of RAM. The device is packaged in a 40-pin DIP, 44-pin PLCC, or a 44-pin QFP with a ROMless pin option available on the 44-pin versions only. With the ROM/ROMless feature selectively, the Z86C21 offers both external memory and preprogrammed ROM, making it well-suited for high-volume applications or where code flexibility is required.

Zilog's CMOS microcontroller offers fast execution, efficient use of memory, sophisticated interrupts, input/output bit manipulation capabilities, and easy hardware/software system expansion along with low cost and low power consumption.

The Z86C21 architecture is characterized by Zilog's 8-bit microcontroller core. The device offers a flexible I/O scheme, an efficient register and address space structure, multiplexed capabilities between address/data, I/O, and a number of ancillary features that are useful in many industrial and advanced scientific applications.

For applications demanding powerful I/O capabilities, the Z86C21 provides 32 pins dedicated to input and output. These lines are grouped into four ports. Each port consists of eight lines, and is configurable under software control to provide timing, status signals, serial or parallel I/O with or without handshake, and an address/data bus for interfacing external memory. There are three basic address spaces available to support this configuration: Program Memory, Data Memory, and 236 general-purpose registers.

GENERAL DESCRIPTION (Continued)

To unburden the program from coping with the real-time tasks, such as counting/timing and serial data communication, the Z86C21 offers two on-chip counter/timers with a large number of user selectable modes, and an on-board UART.

Notes:

All Signals with a preceding front slash, "/", are active Low, e.g., B/W (WORD is active Low); /B/W (BYTE is active Low, only).

Power connections follow conventional descriptions below:

Connection	Circuit	Device
Power Ground	V_{CC} GND	V_{DD} V_{SS}

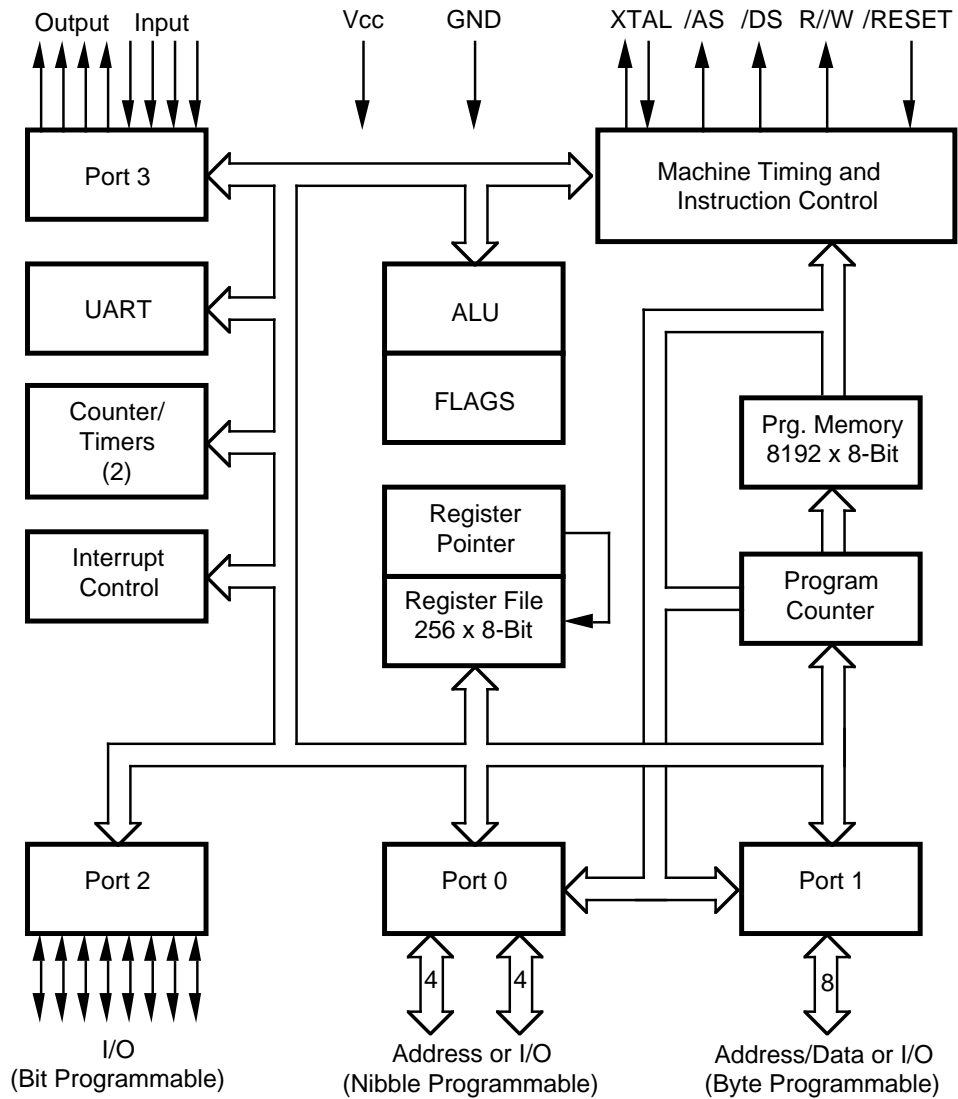
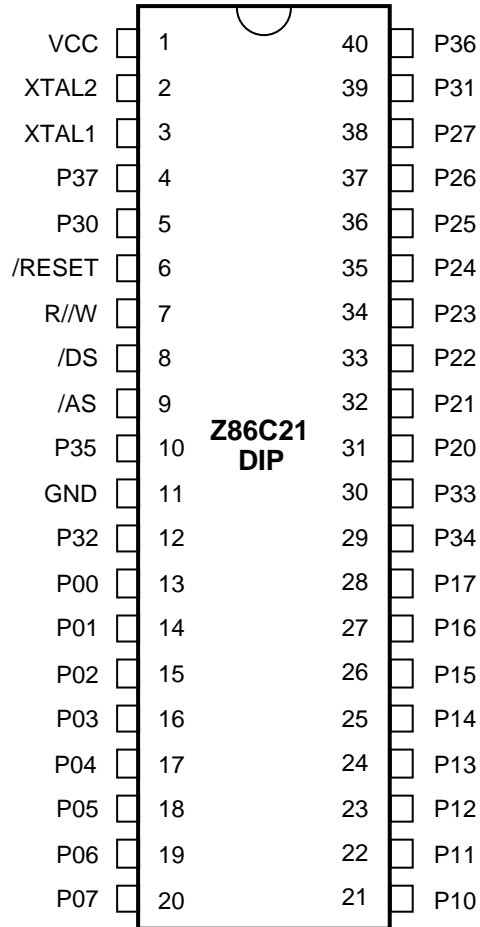
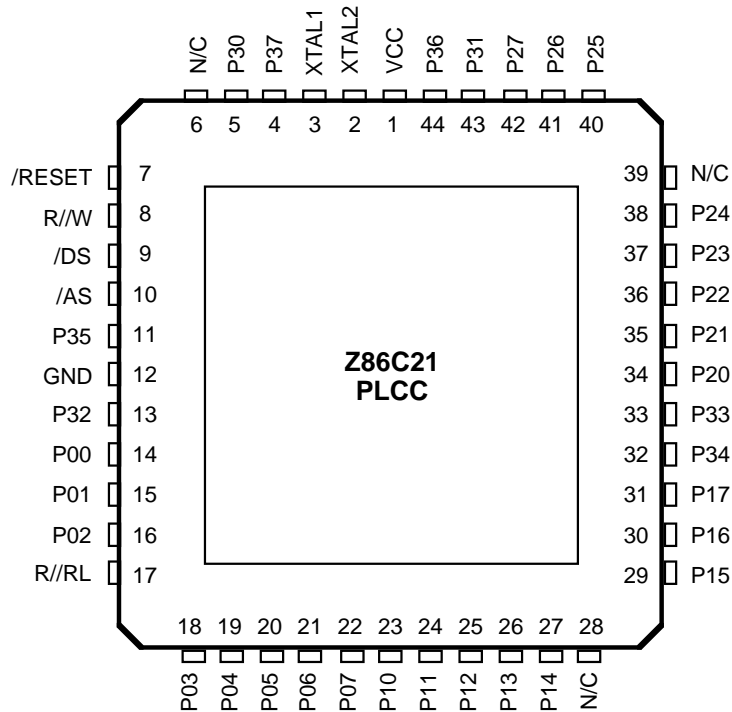

Figure 1. Z86C21 Functional Block Diagram

PIN DESCRIPTION

Figure 2. 40-Pin DIP Pin Assignments
Table 1. 40-Pin DIP Pin Identification

Pin #	Symbol	Function	Direction	Pin #	Symbol	Function	Direction
1	V _{CC}	Power Supply	Input	11	GND	Ground	Input
2	XTAL2	Crystal, Oscillator Clock	Output	12	P32	Port 3, Pin 2	Input
3	XTAL1	Crystal, Oscillator Clock	Input	13-20	P00-P07	Port 0, Pins 0,1,2,3,4,5,6,7	In/Output
4	P37	Port 3, Pin 7	Output	21-28	P10-P17	Port 1, Pins 0,1,2,3,4,5,6,7	In/Output
5	P30	Port 3, Pin 0	Input	29	P34	Port 3, Pin 4	Output
6	/RESET	Reset	Input	30	P33	Port 3, Pin 3	Input
7	R/W	Read/Write	Output	31-38	P20-P27	Port 2, Pins 0,1,2,3,4,5,6,7	In/Output
8	/DS	Data Strobe	Output	39	P31	Port 3, Pin 1	Input
9	/AS	Address Strobe	Output	40	P36	Port 3, Pin 6	Output
10	P35	Port 3, Pin 5	Output				

PIN DESCRIPTION (Continued)

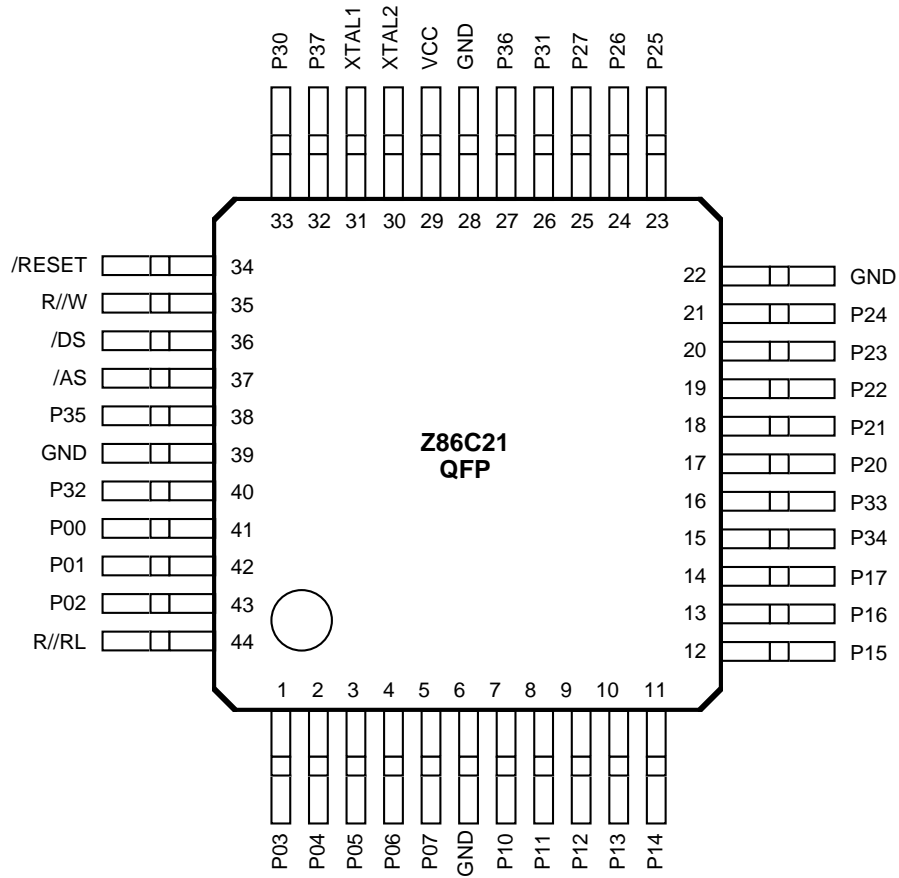
Figure 3. 44-Pin PLCC Pin Assignments
Table 2. 44-Pin PLCC Pin Identification

Pin #	Symbol	Function	Direction	Pin #	Symbol	Function	Direction
1	V _{CC}	Power Supply	Input	14-16	P00-P02	Port 0, Pins 0,1,2	In/Output
2	XTAL2	Crystal, Oscillator Clock	Output	17	R//RL	ROM/ROMless control	Input
3	XTAL1	Crystal, Oscillator Clock	Input	18-22	P03-P07	Port 0, Pins 3,4,5,6,7	In/Output
4	P37	Port 3, Pin 7	Output	23-27	P10-P14	Port 1, Pins 0,1,2,3,4	In/Output
5	P30	Port 3, Pin 0	Input	28	N/C	Not Connected	Input
6	N/C	Not Connected	Input	29-31	P15-P17	Port 1, Pins 5,6,7	In/Output
7	/RESET	Reset	Input	32	P34	Port 3, Pin 4	Output
8	R//W	Read/Write	Output	33	P33	Port 3, Pin 3	Input
9	/DS	Data Strobe	Output	34-38	P20-P24	Port 2, Pins 0,1,2,3,4	In/Output
10	/AS	Address Strobe	Output	39	N/C	Not Connected	Input
11	P35	Port 3, Pin 5	Output	40-42	P25-P27	Port 2, Pins 5,6,7	In/Output
12	GND	Ground	Input	43	P31	Port 3, Pin 1	Input
13	P32	Port 3, Pin 2	Input	44	P36	Port 3, Pin 6	Output

Figure 4. 44-Pin QFP Pin Assignments
Table 3. 44-Pin QFP Pin Identification

Pin #	Symbol	Function	Direction	Pin #	Symbol	Function	Direction
1-5	P03-P07	Port 0, Pins 3,4,5,6,7	In/Output	31	XTAL1	Crystal, Oscillator Clock	Input
6	GND	Ground	Input	32	P37	Port 3, Pin 7	Output
7-14	P10-P17	Port 1, Pins 0 through 7	In/Output	33	P30	Port 3, Pin 0	Input
15	P34	Port 3, Pin 4	Output	34	/RESET	Reset	Input
16	P33	Port 3, Pin 3	Input	35	R//W	Read/Write	Output
17-21	P20-P24	Port 2, Pins 0,1,2,3,4	In/Output	36	/DS	Data Strobe	Output
22	GND	Ground	Input	37	/AS	Address Strobe	Output
23-25	P25-P27	Port 2, Pins 5,6,7	In/Output	38	P35	Port 3, Pin 5	Output
26	P31	Port 3, Pin 1	Input	39	GND	Ground	Input
27	P36	Port 3, Pin 6	Output	40	P32	Port 3, Pin 2	Input
28	GND	Ground	Input	41-43	P00-P02	Port 0, Pins 0,1,2	In/Output
29	V _{CC}	Power Supply	Input	44	R//RL	ROM/ROMless control	Input
30	XTAL2	Crystal, Oscillator Clock	Output				

PIN FUNCTIONS

/ROMless (input, active Low). This pin, when connected to GND, disables the internal ROM and forces the device to function as a Z86C91 ROMless Z8. For more details on the ROMless version, refer to the Z86C91 product specification. (**Note:** When left unconnected or pulled high to V_{CC} , the part functions as a normal Z86C21 ROM version). This pin is only available on the 44-pin versions of the Z86C21.

/DS (output, active Low). Data Strobe is activated once for each external memory transfer. For a READ operation, data must be available prior to the trailing edge of /DS. For WRITE operations, the falling edge of /DS indicates that output data is valid.

/AS (output, active Low). Address Strobe is pulsed once at the beginning of each machine cycle. Address output is through Port 1 for all external programs. Memory address transfers are valid at the trailing edge of /AS. Under program control, /AS is placed in the high-impedance state along with Ports 0 and 1, Data Strobe, and Read/Write.

XTAL1, XTAL2 *Crystal 1, Crystal 2* (time-based input and output, respectively). These pins connect a parallel-resonant crystal, ceramic resonator, LC, or any external single-phase clock to the on-chip oscillator and buffer.

R/W (output, write Low). The Read/Write signal is Low when the MCU is writing to the external program or data memory.

/RESET (input, active Low). To avoid asynchronous and noisy reset problems, the Z86C21 is equipped with a reset filter of four external clocks (4TpC). If the external /RESET signal is less than 4TpC in duration, no reset occurs.

On the fifth clock after the /RESET is detected, an internal RST signal is latched and held for an internal register count of 18 external clocks, or for the duration of the external /RESET, whichever is longer. During the reset cycle, /DS is held active Low while /AS cycles at a rate of TpC2. When /RESET is deactivated, program execution begins at location 000C (HEX). Power-up reset time must be held Low for 50 ms, or until V_{CC} is stable, whichever is longer.

Port 0 (P07-P00). Port 0 is an 8-bit, nibble programmable, bidirectional, TTL compatible port. These eight I/O lines can be configured under software control as a nibble I/O port, or as an address port for interfacing external memory. When used as an I/O port, Port 0 may be placed under handshake control. In this configuration, Port 3, lines P32 and P35 are used as the handshake control /DAV0 and RDY0 (Data Available and Ready). Handshake signal assignment is dictated by the I/O direction of the upper nibble P07-P04. The lower nibble must have the same direction as the upper nibble to be under handshake control.

For external memory references, Port 0 can provide address bits A11-A8 (lower nibble) or A15-A8 (lower and upper nibble) depending on the required address space. If the address range requires 12 bits or less, the upper nibble of Port 0 is programmed independently as I/O while the lower nibble is used for addressing. If one or both nibbles are needed for I/O operation, they must be configured by writing to the Port 0 Mode register.

In ROMless mode, after a hardware reset, Port 0 lines are defined as address lines A15-A8, and extended timing is set to accommodate slow memory access. The initialization routine includes reconfiguration to eliminate this extended timing mode (Figure 5).

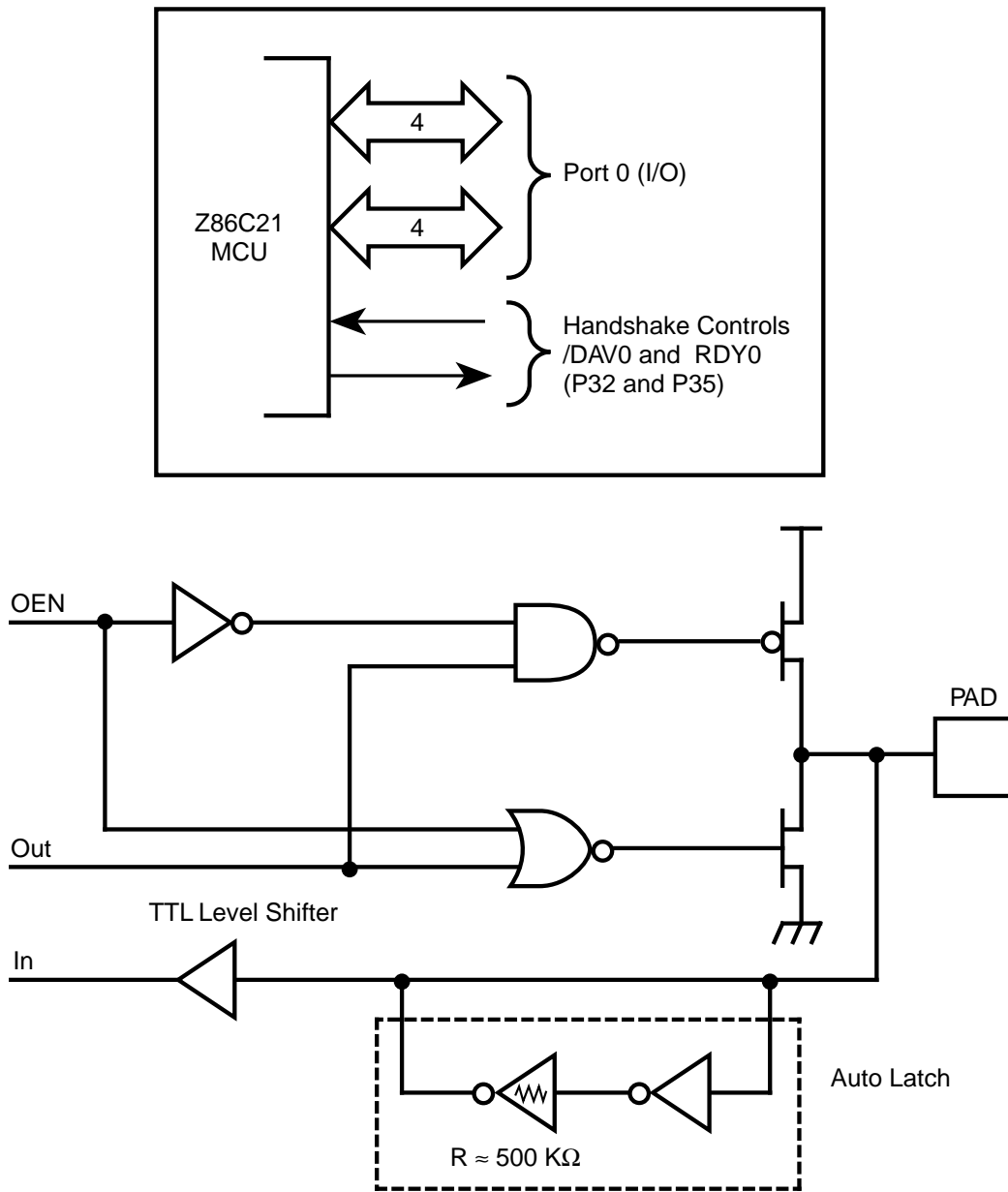

Figure 5. Port 0 Configuration

PIN FUNCTIONS (Continued)

Port 1 (P17-P10). Port 1 is an 8-bit, byte programmable, bidirectional, TTL compatible port. It has multiplexed Address (A7-A0) and Data (D7-D0) ports. For Z86C21, these eight I/O lines can be programmed as Input or Output lines or can be configured under software control as an address/data port for interfacing external memory. When used as an I/O port, Port 1 can be placed under handshake control. In this configuration, Port 3 line P33 and P34 are used as the handshake controls RDY1 and /DAV1.

Memory locations greater than 8192 are referenced through Port 1. To interface external memory, Port 1 is programmed

for the multiplexed Address/Data mode. If more than 256 external locations are required, Port 0 must output the additional lines.

Port 1 can be placed in a high-impedance state along with Port 0, /AS, /DS and R/W, allowing the MCU to share common resource in multiprocessor and DMA applications. Data transfers are controlled by assigning P33 as a Bus Acknowledge input, and P34 as a Bus request output (Figure 6).

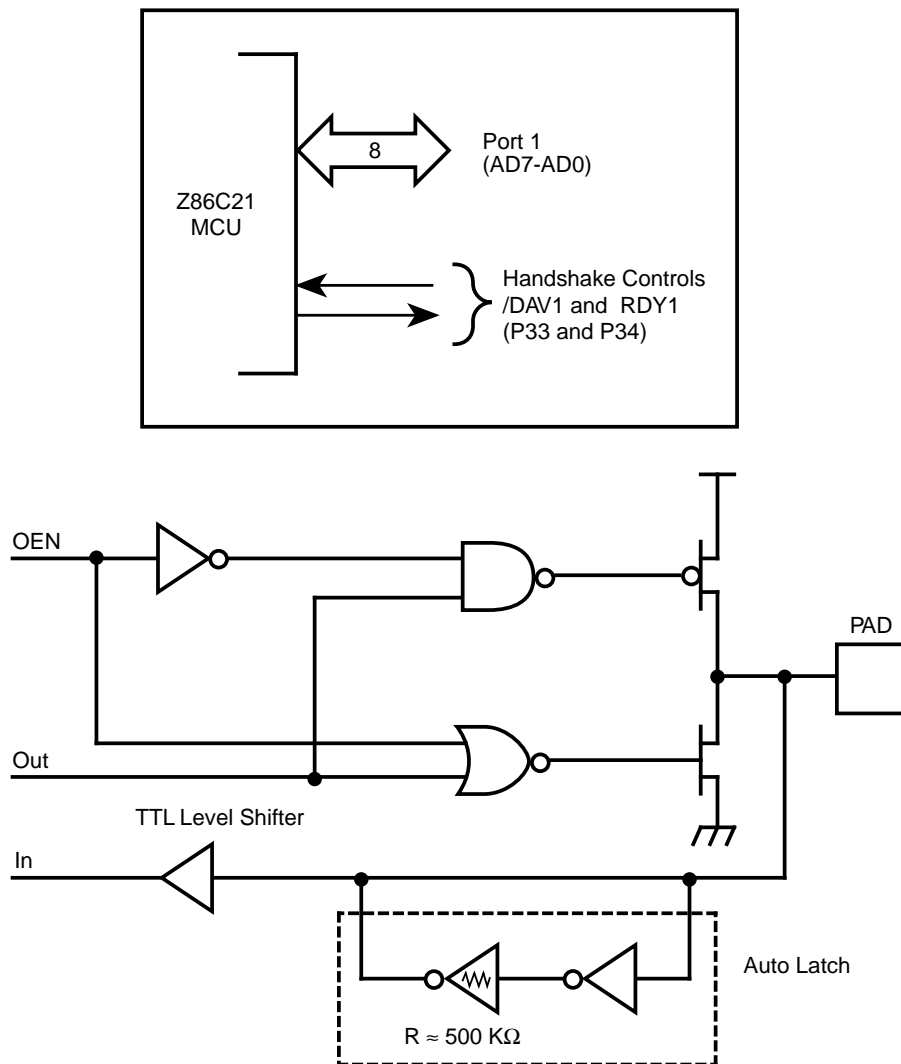

Figure 6. Port 1 Configuration

Port 2 (P27-P20). Port 2 is an 8-bit, bit programmable, bidirectional, CMOS compatible port. Each of these eight I/O lines can be independently programmed as an input or output or globally as an open-drain output. Port 2 is always available for I/O operation. When used as an I/O port, Port 2 may be placed under handshake control. In this

configuration, Port 3 lines P31 and P36 are used as the handshake control lines /DAV2 and RDY2. The handshake signal assignment for Port 3 lines P31 and P36 is dictated by the direction (input or output) assigned to P27 (Figure 7).

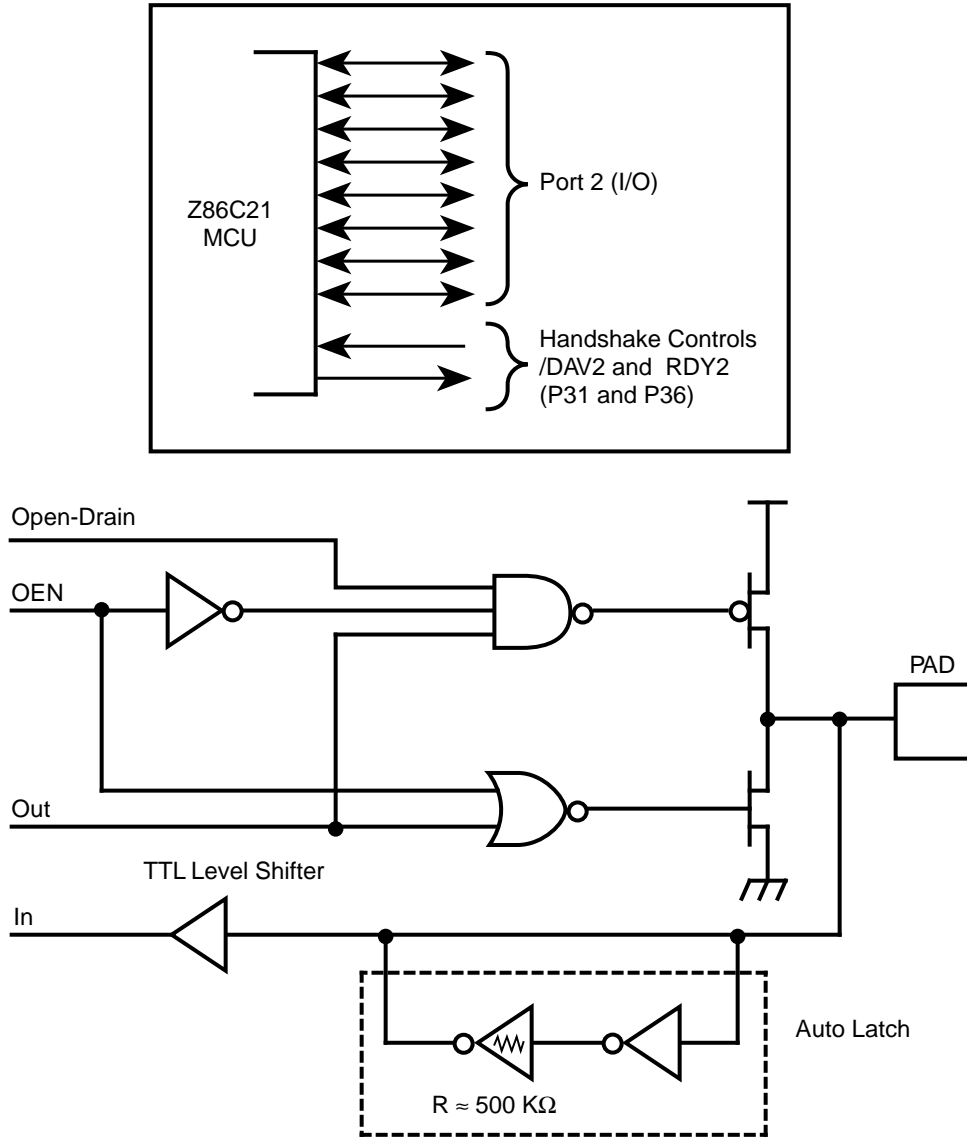

Figure 7. Port 2 Configuration

PIN FUNCTIONS (Continued)

Port 3 (P37-P30). Port 3 is an 8-bit, CMOS compatible four-fixed-input and four-fixed-output port. These eight I/O lines have four-fixed input (P33-P30) and four fixed output (P37-P34) ports. Port 3, when used as serial I/O, is programmed as serial in and serial out, respectively (Figure 8 and Table 4) Port 3 pins have Auto Latches only.

Port 3 is configured under software control to provide the following control functions: handshake for Ports 0 and 2 (/DAV and RDY); four external interrupt request signals (IRQ3-IRQ0); timer input and output signals (T_{IN} and T_{OUT}), and Data Memory Select (/DM).

UART Operation. Port 3 lines P30 and P37, are be programmed as serial I/O lines for full-duplex serial asynchro-

nous receiver/transmitter operation. The bit rate is controlled by the Counter/Timer0.

The Z86C21 automatically adds a start bit and two stop bits to transmitted data (Figure 9). Odd parity is also available as an option. Eight data bits are always transmitted, regardless of parity selection. If parity is enabled, the eighth bit is the odd parity bit. An interrupt request (IRQ4) is generated on all transmitted characters.

Received data must have a start bit, eight data bits and at least one stop bit. If parity is on, bit 7 of the received data is replaced by a parity error flag. Received characters generate the IRQ3 interrupt request.

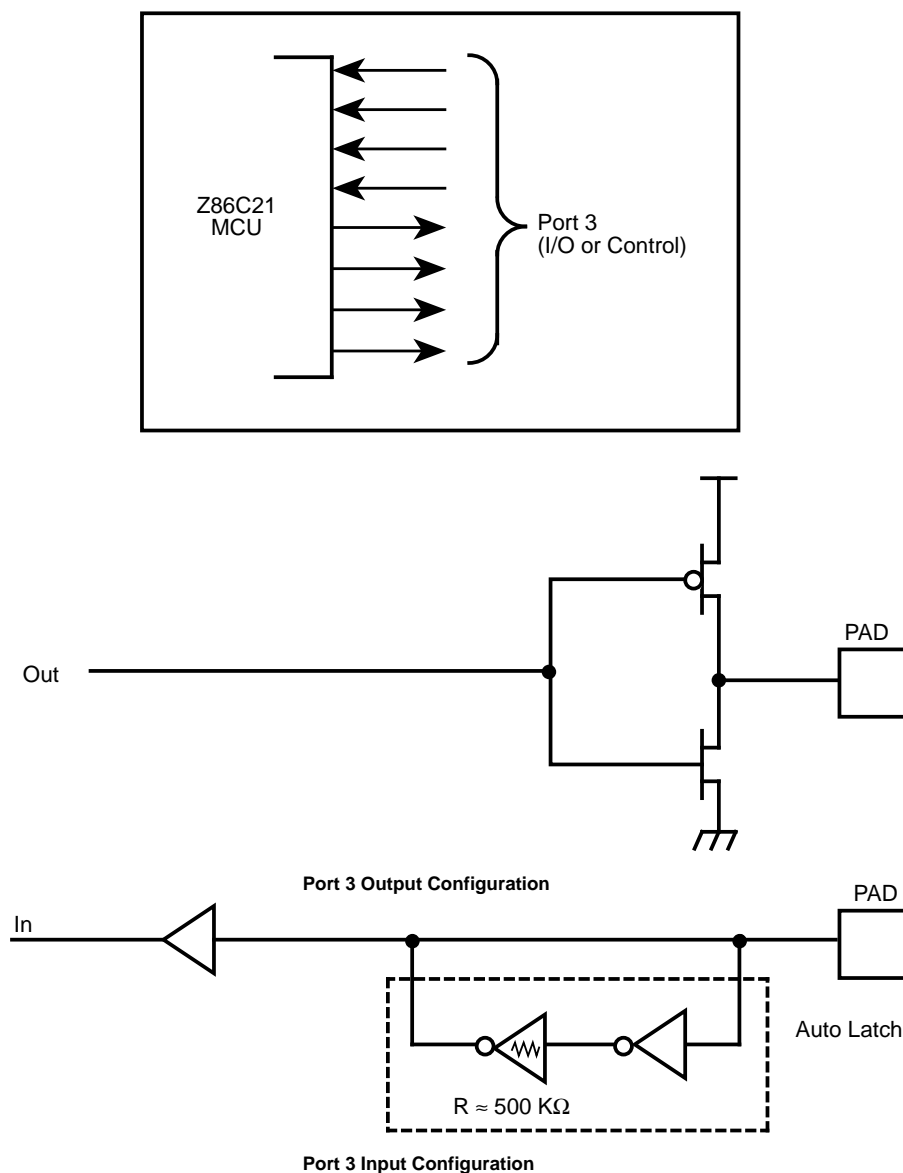

Figure 8. Port 3 Configuration

Table 4. Port 3 Pin Assignments

Pin	I/O	CTC1	Int.	P0 HS	P1 HS	P2 HS	UART	Ext
P30	IN		IRQ3				Serial In	
P31	IN	T _{IN}	IRQ2			D/R		
P32	IN		IRQ0	D/R				
P33	IN		IRQ1		D/R			
P34	OUT				R/D			DM
P35	OUT			R/D				
P36	OUT	T _{OUT}				R/D		
P37	OUT						Serial Out	
T0			IRQ4					
T1			IRQ5					

Notes:

HS = Handshake Signals; D = Data Available; R = Ready

Auto Latch. The Auto Latch puts valid CMOS levels on all CMOS inputs that are not externally driven. This reduces excessive supply current flow in the input buffer when it is not been driven by any source.

Low EMI Option. The Z86C21 is available in a Low EMI option. This option is mask-programmable, to be selected by the customer at the time when the ROM code is submitted. Use of this feature results in:

- The pre-drivers slew rate reduced to 10 ns typical.
- Low EMI output drivers have resistance of 200 Ohms typical.
- Oscillator divide-by-two circuitry is eliminated.
- Internal SCLK/TCLK operation is limited to a maximum of 4 MHz (250 ns cycle time)

Transmitted Data (No Parity)

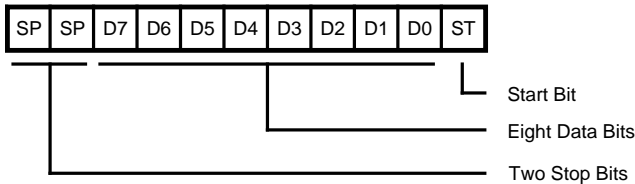

Received Data (No Parity)

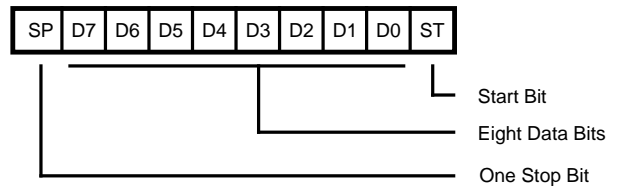

Transmitted Data (With Parity)

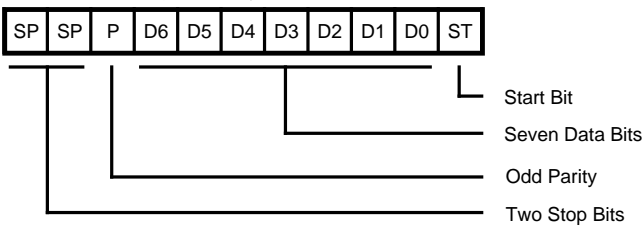

Received Data (With Parity)

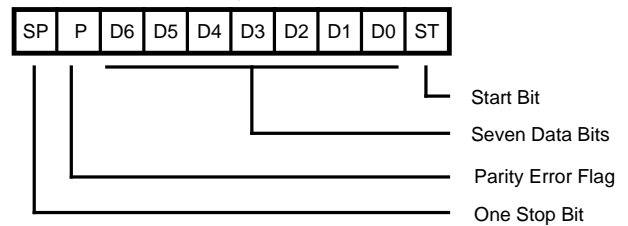
Figure 9. Serial Data Formats

FUNCTIONAL DESCRIPTION

Address Space

Program Memory. The Z86C21 can address up to 56K bytes of external program memory (Figure 10). The first 12 bytes of program memory are reserved for the interrupt vectors. These locations contain six 16-bit vectors that correspond to the six available interrupts. For ROM mode, byte 13 to byte 8191 consists of on-chip ROM. At addresses 8192 and greater, the Z86C21 executes external program memory fetches. In the ROMless mode, the Z86C21 can address up to 64K bytes of external program memory. Program execution begins at external location 000C (HEX) after a reset.

Data Memory (/DM). The ROM version can address up to 56K bytes of external data memory space beginning at location 8192. The ROMless version can address up to 64K bytes of external data memory. External data memory can be included with, or separated from, the external program memory space. /DM, an optional I/O function that can be programmed to appear on P34, is used to distinguish between data and program memory space (Figure 11). The state of the /DM signal is controlled by the type instruction being executed. An LDC opcode references PROGRAM (/DM inactive) memory, and an LDE instruction references DATA (/DM active Low) memory.

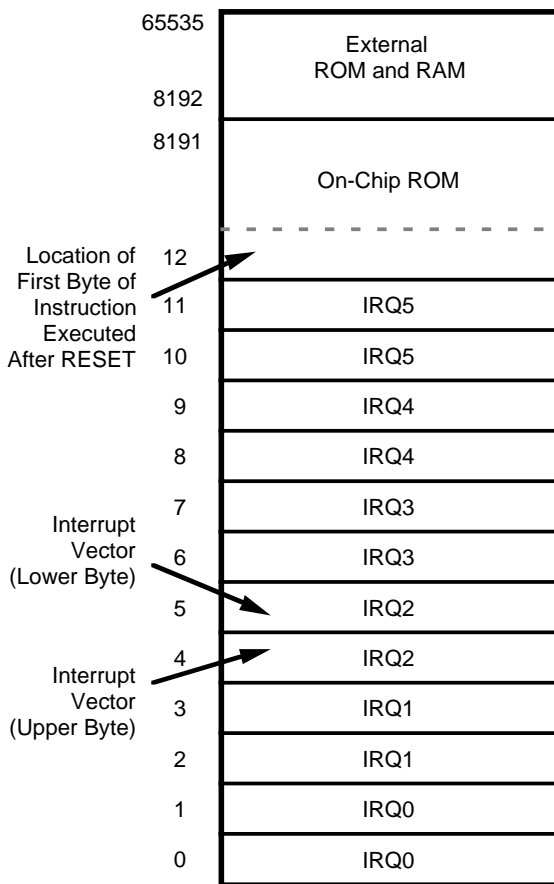

Figure 10. Program Memory Configuration

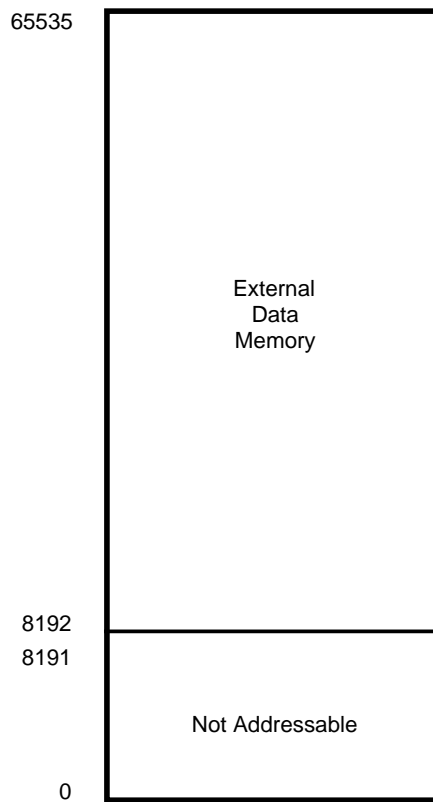

Figure 11. Data Memory Configuration

Register File. The Register File consists of four I/O port registers, 236 general-purpose registers and 16 control and status registers (Figure 12). The instructions can access registers directly or indirectly through an 8-bit address field. The Z86C21 also allows short 4-bit register addressing using the Register Pointer (Figure 13). In the 4-bit mode, the Register File is divided into 16 working

register groups, each occupying 16 continuous locations. The Register Pointer addresses the starting location of the active working-register group. For the reset and power-up conditions of the Register File, see Figure 14.

Note: Register Bank E0-EF can only be accessed through working registers and indirect addressing modes.

LOCATION		IDENTIFIERS	
R255	Stack Pointer (Bits 7-0)	SPL	
R254	Stack Pointer (Bits 15-8)	SPH	
R253	Register Pointer	RP	
R252	Program Control Flags	FLAGS	
R251	Interrupt Mask Register	IMR	
R250	Interrupt Request Register	IRQ	
R249	Interrupt Priority Register	IPR	
R248	Ports 0-1 Mode	P01M	
R247	Port 3 Mode	P3M	
R246	Port 2 Mode	P2M	
R245	T0 Prescaler	PRE0	
R244	Timer/Counter0	T0	
R243	T1 Prescaler	PRE1	
R242	Timer/Counter1	T1	
R241	Timer Mode	TMR	
R240	Serial I/O	SIO	
R239	General-Purpose Registers		
R4			
R3		Port 3	P3
R2		Port 2	P2
R1	Port 1	P1	
R0	Port 0	P0	

Figure 12. Register File

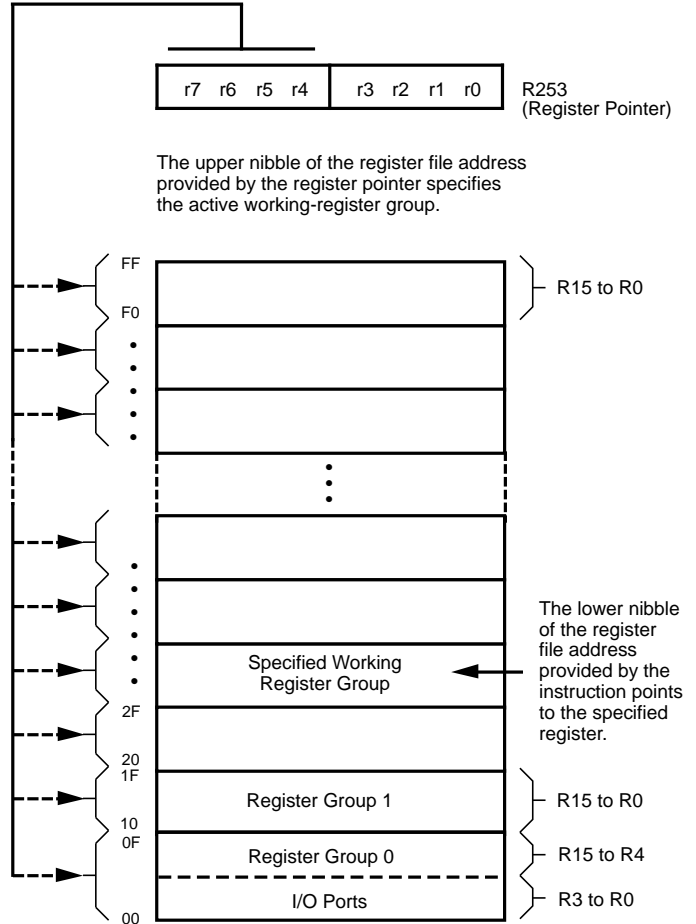

Figure 13. Register Pointer

FUNCTIONAL DESCRIPTION (Continued)

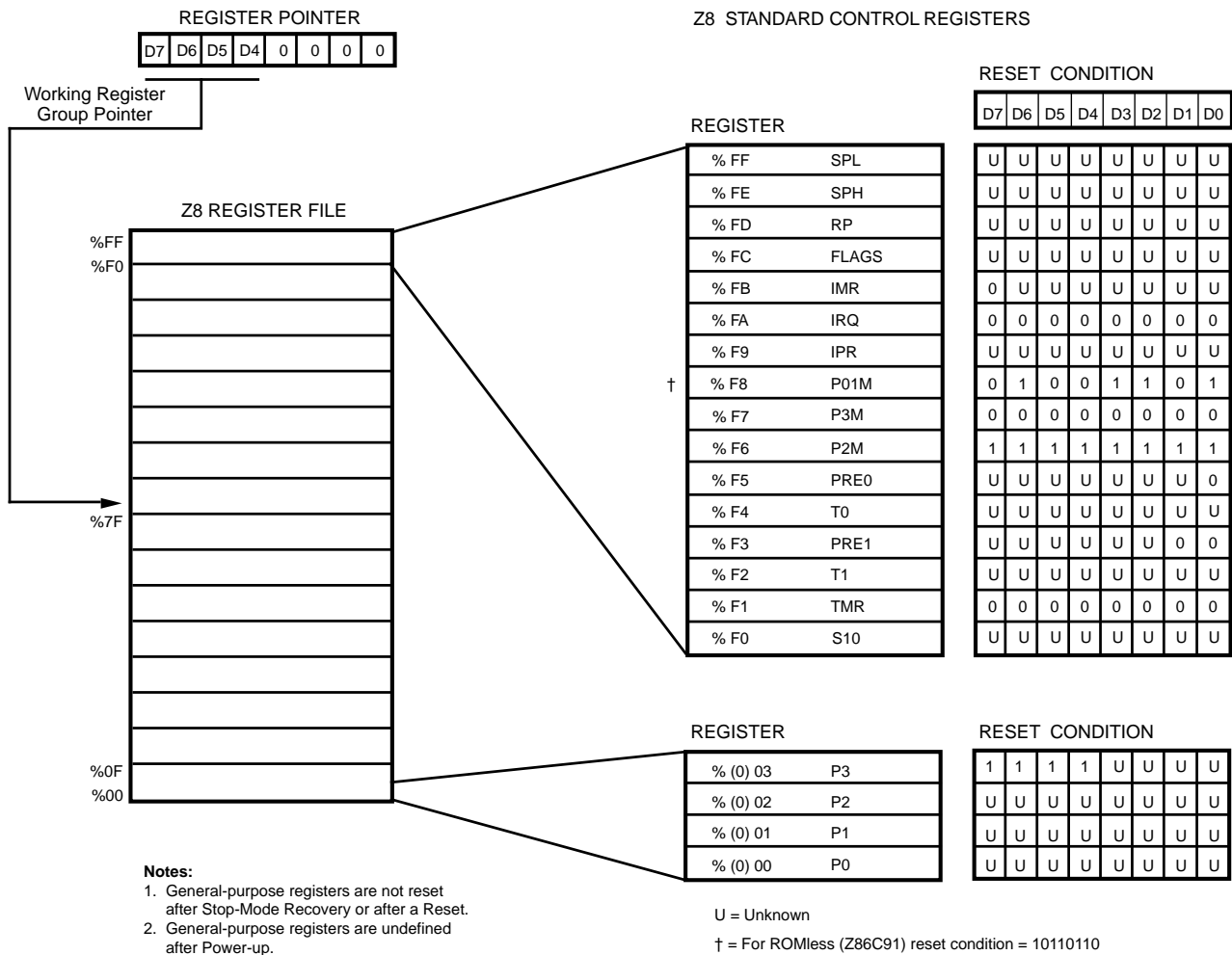

Figure 14. RAM Register File Reset Condition

RAM Protect. The upper portion of the RAM's address spaces 80FH to EFH (excluding the control registers) can be protected from reading and writing. The RAM Protect bit option is mask-programmable and is selected by the customer when the ROM code is submitted. After the mask option is selected, the user activates from the internal ROM code to turn off/on the RAM Protect by loading a bit D6 in the IMR register to either a 0 or a 1, respectively. A 1 in D6 indicates RAM Protect enabled.

ROM Protect. The first 8 Kbytes of program memory is mask programmable. A ROM protect feature prevents dumping of the ROM contents by inhibiting execution of LDC, LDCI, LDE, and LDEI instructions to Program Memory in all modes.

The ROM Protect option is mask-programmable, to be selected by the customer at the time when the ROM code is submitted.

Note: With RAM/ROM protect on, the Z86C21 cannot access the memory space.

Stack. The Z86C21 has a 16-bit Stack Pointer (R254-R255) used for external stack that resides anywhere in the data memory for the ROMless mode, but only from 8192 to 65535 in the ROM mode. An 8-bit Stack Pointer (R255) is used for the internal stack that resides within the 236 general-purpose registers (R4-R239). The high byte of the Stack Pointer (SPH-Bit 8-15) is used as a general-purpose register when using internal stack only.

Counter/Timers. There are two 8-bit programmable counter/timers (T0-T1), each driven by its own 6-bit programmable prescaler. The T1 prescaler is driven by internal or external clock sources; however, the T0 prescaler is driven by the internal clock only (Figure 15).

The 6-bit prescalers divides the input frequency of the clock source by any integer number from 1 to 64. Each prescaler drives its counter, which decrements the value (1 to 256) that has been loaded into the counter. When both the counter and prescaler reach the end of the count, a timer interrupt request, IRQ4 (T0) or IRQ5 (T1), is generated.

The counter can be programmed to start, stop, restart to continue, or restart from the initial value. The counters can

also be programmed to stop upon reaching zero (single pass mode) or to automatically reload the initial value and continue counting (modulo-n continuous mode).

The counter, but not the prescalers, can be read at any time without disturbing their value or count mode. The clock source for T1 is user-definable and can be either the internal microprocessor clock divided by four, or an external signal input through Port 3. The Timer Mode register configures the external timer input (P31) as an external clock, a trigger input that is retriggerable or non-retriggerable, or as a gate input for the internal clock. Port 3, line P36, also serves as a timer output (T_{OUT}) through which T0, T1 or the internal clock is output. The counter/timers are cascaded by connecting the T0 output to the input of T1.

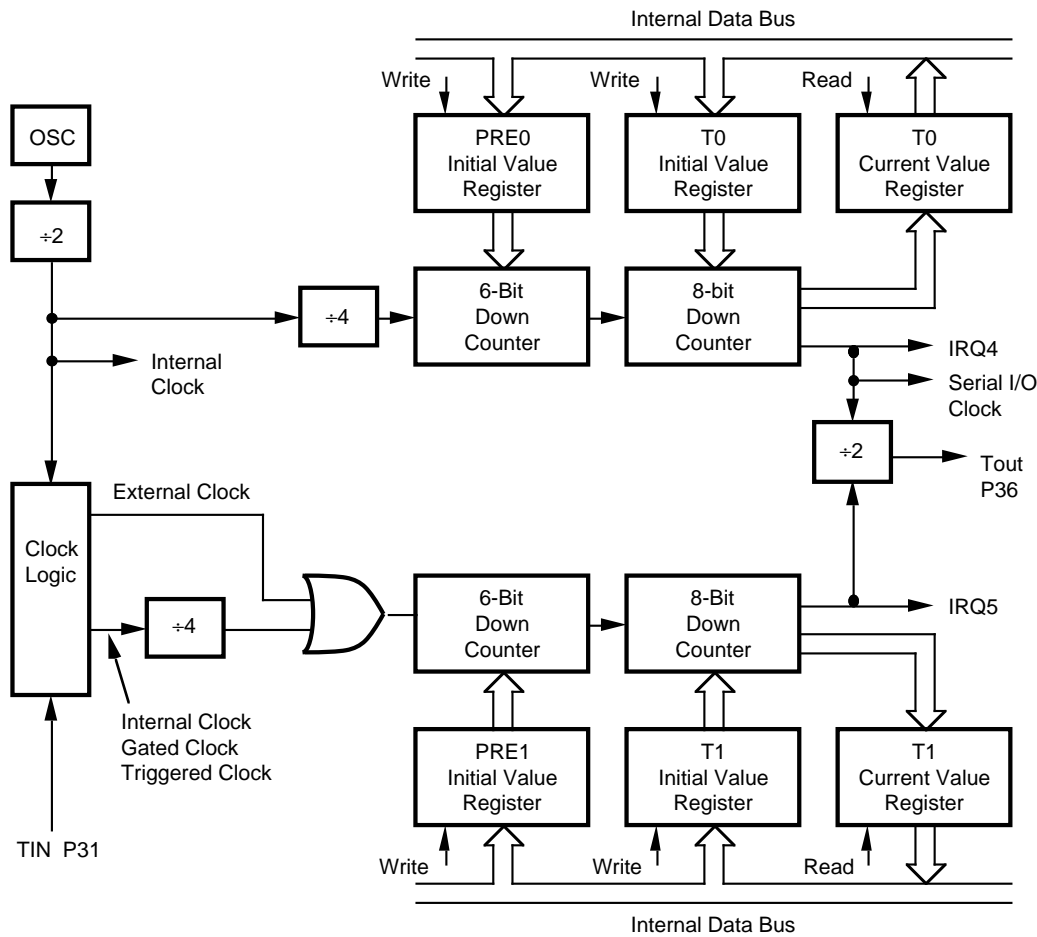

Figure 15. Counter/Timers Block Diagram

FUNCTIONAL DESCRIPTION (Continued)

Interrupts. The Z86C21 has six different interrupts from eight different sources. The interrupts are maskable and prioritized. The eight sources are divided as follow: four sources are claimed by Port 3, lines P33-P30; one in Serial Out, one in Serial In, and two in the counter/timers (Figure 16). The Interrupt Mask Register globally or individually enables or disables the six interrupt requests. When more than one interrupt is pending, priorities are resolved by a programmable priority encoder that is controlled by the Interrupt Priority register. (Refer to Table 4.)

All Z86C21 interrupts are vectored through locations in the program memory. When an interrupt machine cycle is activated, an interrupt request is granted. Thus, this disables all of the subsequent interrupts, save the Program Counter and Status Flags, and then branches to the program memory vector location reserved for that interrupt. This memory location and the next byte contain the 16-bit address of the interrupt service routine for that particular interrupt request.

To accommodate polled interrupt systems, interrupt inputs are masked and the Interrupt Request register is polled to determine which of the interrupt requests need service. Software initiated interrupts are supported by setting the appropriate bit in the Interrupt Request Register (IRQ).

Internal interrupt requests are sampled on the falling edge of the last cycle of every instruction, and the interrupt request must be valid 5TpC before the falling edge of the last clock cycle of the currently executing instruction.

For the ROMless mode, when the device samples a valid interrupt request, the next 48 (external) clock cycles are used to prioritize the interrupt, and push the two PC bytes and the FLAG register on the stack. The following nine cycles are used to fetch the interrupt vector from external memory. The first byte of the interrupt service routine is fetched beginning on the 58th TpC cycle following the internal sample point, which corresponds to the 63rd TpC cycle following the external interrupt sample point.

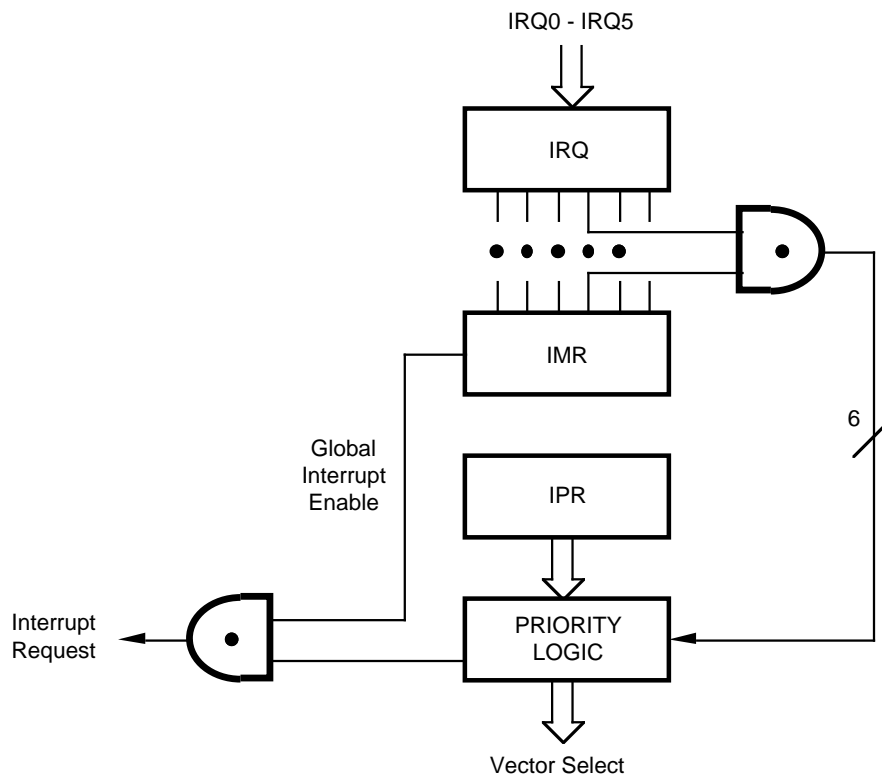

Figure 16. Interrupt Block Diagram

Clock. The Z86C21 on-chip oscillator has a high-gain, parallel-resonant amplifier for connection to a crystal, LC, ceramic resonator, or any suitable external clock source (XTAL1 = Input, XTAL2 = Output). The crystal should be AT cut, 1 MHz to 16 MHz max, and series resistance (RS) is less than or equal to 100 Ohms. The crystal should be connected across XTAL1 and XTAL2 using the recom-

mended capacitors ($10\text{ pF} < C_L < 300\text{ pF}$) from each pin 11, ground instead of just system ground. This prevents noise injection into the clock input (Figure 17).

Note: Actual capacitor value is specified by the crystal manufacturer.

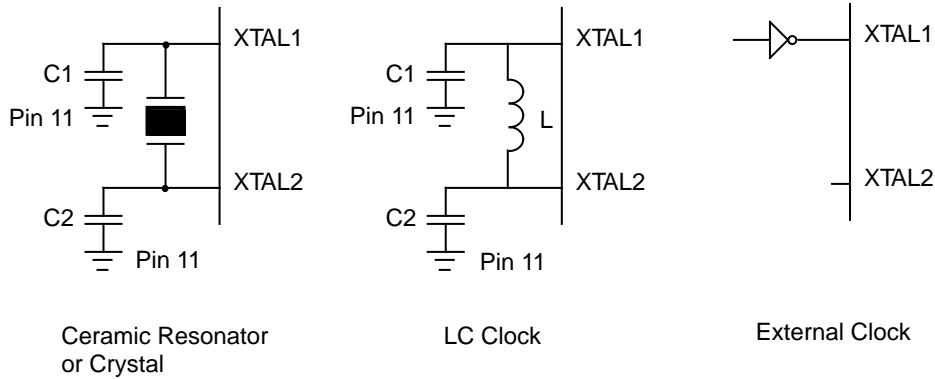

Figure 17. Oscillator Configuration

HALT. Turns off the internal CPU clock but not the XTAL oscillation. The counter/timers and the external interrupts IRQ0, IRQ1, IRQ2, and IRQ3 remain active. The device is recovered by interrupts, either externally or internally generated. An interrupt request must be executed (enabled) to exit HALT mode. After the interrupt service routine, the program continues from the instruction after the HALT.

STOP. This instruction turns off the internal clock and external crystal oscillation and reduces the standby current to $5\text{ }\mu\text{A}$ (typical) or less. The STOP mode is terminated by a reset which causes the processor to restart the application program at address 000C (HEX).

In order to enter STOP (or HALT) mode, it is necessary to first flush the instruction pipeline to avoid suspending execution in mid-instruction. To do this, the user must execute a NOP (opcode=0FFH) immediately before the appropriate sleep instruction. i.e.,

```
FF NOP ; clear the pipeline
6F STOP ; enter STOP mode
or
FF NOP ; clear the pipeline
7F HALT ; enter HALT mode
```

ABSOLUTE MAXIMUM RATINGS

Symbol	Description	Min	Max	Units
V_{CC}	Supply Voltage*	-0.3	+7.0	V
T_{STG}	Storage Temp	-65	+150	°C
T_A	Oper Ambient Temp		†	°C

Notes:

* Voltages on all pins with respect to GND.

† See Ordering Information

Stresses greater than those listed under Absolute Maximum Ratings may cause permanent damage to the device. This is a stress rating only; operation of the device at any condition above those indicated in the operational sections of these specifications is not implied. Exposure to absolute maximum rating conditions for an extended period may affect device reliability.

STANDARD TEST CONDITIONS

The characteristics listed below apply for standard test conditions as noted. All voltages are referenced to GND. Positive current flows into the referenced pin (Figure 18).

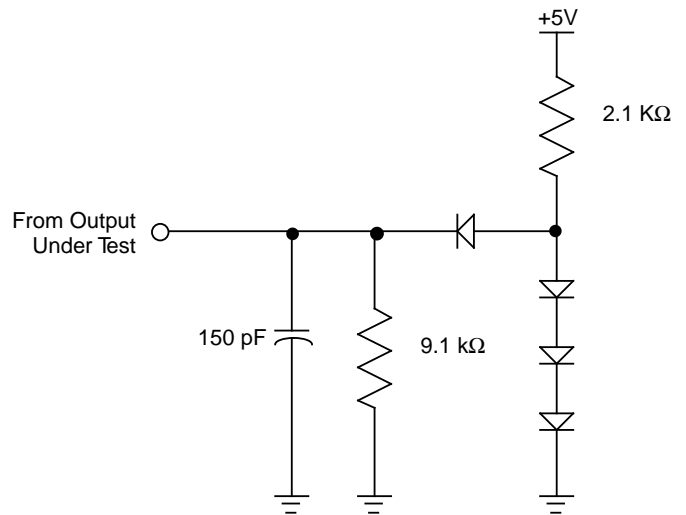

Figure 18. Test Load Diagram

DC CHARACTERISTICS

Sym	Parameter	$T_A = 0^\circ\text{C}$ to $+70^\circ\text{C}$		$T_A = -40^\circ\text{C}$ to $+105^\circ\text{C}$		Typical @ 25°C	Units	Conditions
		Min	Max	Min	Max			
	Max Input Voltage		7		7		V	$I_{IN} < 250 \mu\text{A}$
V_{CH}	Clock Input High Voltage	3.8	$V_{CC}+0.3$	3.8	$V_{CC}+0.3$		V	Driven by External Clock Generator
V_{CL}	Clock Input Low Voltage	-0.3	0.8	-0.3	0.8		V	Driven by External Clock Generator
V_{IH}	Input High Voltage	2	$V_{CC}+0.3$	2.0	$V_{CC}+0.3$		V	
V_{IL}	Input Low Voltage	-0.3	0.8	-0.3	0.8		V	
V_{OH}	Output High Voltage	2.4		2.4			V	$I_{OH} = -2.0 \text{ mA}$
V_{OH}	Output High Voltage	$V_{CC} - 100 \text{ mV}$		$V_{CC} - 100 \text{ mV}$			V	$I_{OH} = -100 \mu\text{A}$
V_{OL}	Output Low Voltage		0.4		0.4		V	$I_{OL} = +5.0 \text{ mA}$
V_{RH}	Reset Input High Voltage	3.8	$V_{CC}+0.3$	3.8	$V_{CC}+0.3$		V	
V_{RI}	Reset Input Low Voltage	-0.3	0.8	-0.3	0.8		V	
I_{IL}	Input Leakage	-2	2	-2	2		μA	$V_{IN} = 0\text{V}, V_{CC}$
I_{OL}	Output Leakage	-2	2	-2	2		μA	$V_{IN} = 0\text{V}, V_{CC}$
I_{IR}	Reset Input Current		-80		-80		μA	$V_{RL} = 0\text{V}$
I_{CC}	Supply Current		30		30	20	mA	[1] @ 12 MHz
			35		35	24	mA	[1] @ 16 MHz
I_{CC1}	Standby Current		6.5		6.5	4	mA	[1] HALT mode $V_{IN} = 0\text{V}, V_{CC}$ @ 12 MHz
			7		7	4.5	mA	[1] HALT mode $V_{IN} = 0\text{V}, V_{CC}$ @ 16 MHz
I_{CC2}	Standby Current		10		20	1	μA	[1] STOP mode $V_{IN} = 0\text{V}, V_{CC}$
I_{ALL}	Auto Latch Low Current	-10	10	-14	14	5	μA	

Note:

[1] All inputs driven to either 0V or V_{CC} , outputs floating.

AC CHARACTERISTICS

External I/O or Memory Read or Write Timing Diagram

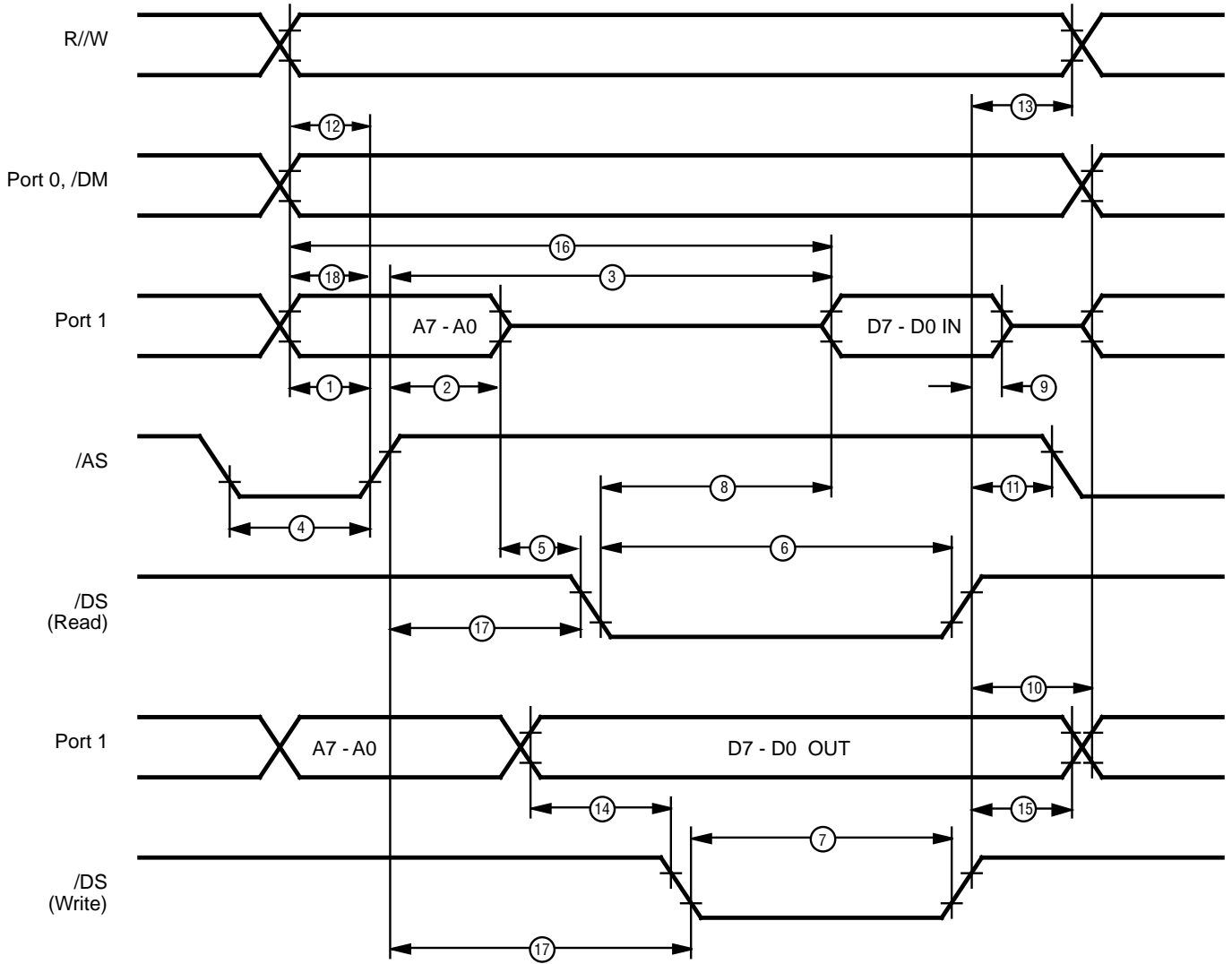

Figure 19. External I/O or Memory Read/Write Timing

AC CHARACTERISTICS

External I/O or Memory Read or Write Timing Table

No	Symbol	Parameter	$T_A = 0^\circ\text{C to } +70^\circ\text{C}$				$T_A = -40^\circ\text{C to } +105^\circ\text{C}$				Units	Notes
			12 MHz		16 MHz		12 MHz		16 MHz			
			Min	Max	Min	Max	Min	Max	Min	Max		
1	TdA(AS)	Address Valid to /AS Rise Delay	35		25		35		25		ns	[2,3]
2	TdAS(A)	/AS Rise to Address Float Delay	45		35		45		35		ns	[2,3]
3	TdAS(DR)	/AS Rise to Read Data Req'd Valid		250		180		250		180	ns	[1,2,3]
4	TwAS	/AS Low Width	55		40		55		40		ns	[2,3]
5	TdAZ(DS)	Address Float to /DS Fall	0		0		0		0		ns	
6	TwDSR	/DS (Read) Low Width	185		135		185		135		ns	[1,2,3]
7	TwDSW	/DS (Write) Low Width	110		80		110		80		ns	[1,2,3]
8	TdDSR(DR)	/DS Fall to Read Data Req'd Valid		130		75		130		75	ns	[1,2,3]
9	ThDR(DS)	Read Data to /DS Rise Hold Time	0		0		0		0		ns	[2,3]
10	TdDS(A)	/DS Rise to Address Active Delay	65		50		65		50		ns	[2,3]
11	TdDS(AS)	/DS Rise to /AS Fall Delay	45		35		45		35		ns	[2,3]
12	TdR/W(AS)	R/W Valid to /AS Rise Delay	30		20		33		25		ns	[2,3]
13	TdDS(R/W)	/DS Rise to R/W Not Valid	50		35		50		35		ns	[2,3]
14	TdDW(DSW)	Write Data Valid to /DS Fall (Write) Delay	35		25		35		25		ns	[2,3]
15	TdDS(DW)	/DS Rise to Write Data Not Valid Delay	55		35		55		35		ns	[2,3]
16	TdA(DR)	Address Valid to Read Data Req'd Valid		310		230		310		230	ns	[1,2,3]
17	TdAS(DS)	/AS Rise to /DS Fall Delay	65		45		65		45		ns	[2,3]
18	TdDM(AS)	/DM Valid to /AS Rise Delay	50		30		50		30		ns	[2,3]

Notes:

- [1] When using extended memory timing add 2 TpC.
 [2] Timing numbers given are for minimum TpC.
 [3] See clock cycle dependent characteristics table.

Standard Test Load

All timing references use 2.0V for a logic 1 and 0.8V for a logic 0.

Clock Dependent Formulas

Number	Symbol	Equation
1	TdA(AS)	$0.40\text{TpC} + 0.32$
2	TdAS(A)	$0.59\text{TpC} - 3.25$
3	TdAS(DR)	$2.83\text{TpC} + 6.14$
4	TwAS	$0.66\text{TpC} - 1.65$
6	TwDSR	$2.33\text{TpC} - 10.56$
7	TwDSW	$1.27\text{TpC} + 1.67$
8	TdDSR(DR)	$1.97\text{TpC} - 42.5$
10	TdDS(A)	0.8TpC
11	TdDS(AS)	$0.59\text{TpC} - 3.14$
12	TdR/W(AS)	0.4TpC
13	TdDS(R/W)	$0.8\text{TpC} - 15$
14	TdDW(DSW)	0.4TpC
15	TdDS(DW)	$0.88\text{TpC} - 19$
16	TdA(DR)	$4\text{TpC} - 20$
17	TdAS(DS)	$0.91\text{TpC} - 10.7$
18	TdDM(AS)	$0.9\text{TpC} - 26.3$

AC CHARACTERISTICS

Additional Timing Diagram

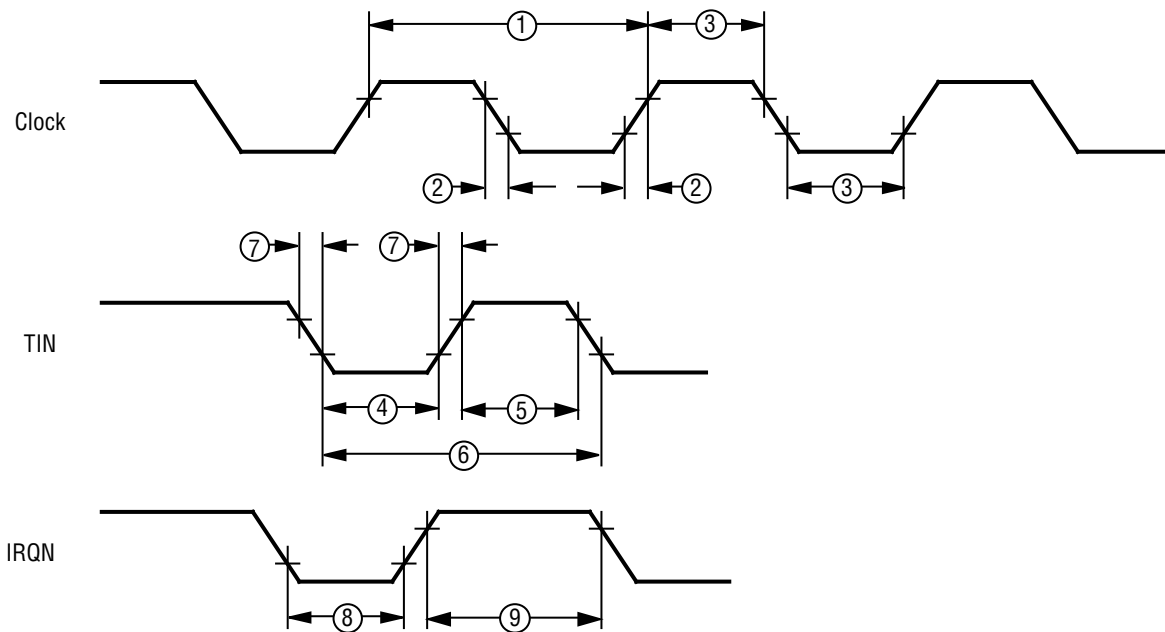

Figure 20. Additional Timing

AC CHARACTERISTICS

Additional Timing Table

No	Sym	Parameter	$T_A = 0^\circ\text{C to } +70^\circ\text{C}$		$T_A = -40^\circ\text{C to } +105^\circ\text{C}$		Units	Notes
			12 MHz	16 MHz	12 MHz	16 MHz		
1	TpC	Input Clock Period	83	1000	62.5	1000	ns	[1]
2	TrC,TfC	Clock Input Rise & Fall Times		15		10	ns	[1]
3	TwC	Input Clock Width	35		25		ns	[1]
4	TwTinL	Timer Input Low Width	75		75		ns	[2]
5	TwTinH	Timer Input High Width	3TpC		3TpC			[2]
6	TpTin	Timer Input Period	8TpC		8TpC			[2]
7	TrTin,TfTin	Timer Input Rise & Fall Times	100		100		ns	[2]
8A	TwIL	Interrupt Request Input Low Times	70		70		ns	[2,4]
8B	TwIL	Interrupt Request Input Low Times	3TpC		3TpC			[2,5]
9	TwIH	Interrupt Request Input High Times	3TpC		3TpC			[2,3]

Notes:

- [1] Clock timing references use 3.8V for a logic 1 and 0.8V for a logic 0.
- [2] Timing references use 2.0V for a logic 1 and 0.8V for a logic 0.
- [3] Interrupt references request through Port 3.
- [4] Interrupt request through Port 3 (P33-P31).
- [5] Interrupt request through Port 30.

AC CHARACTERISTICS

Handshake Timing Diagrams

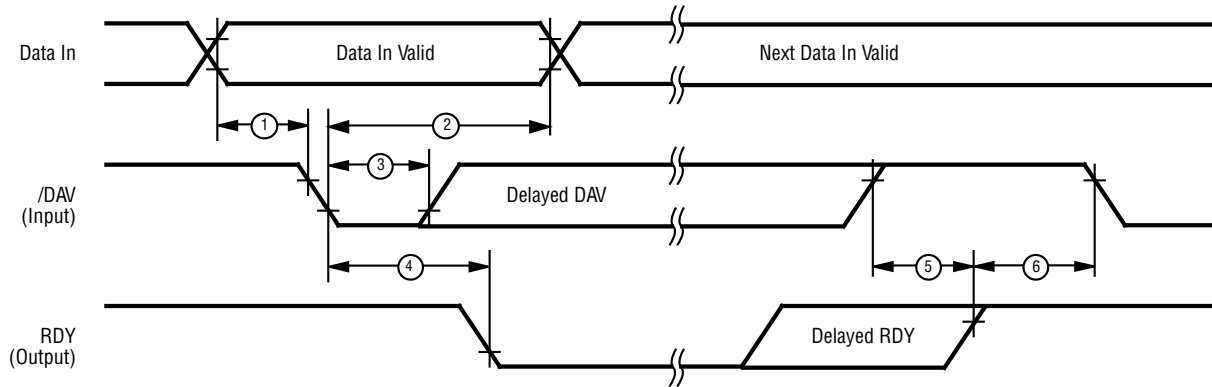

Figure 21. Input Handshake Timing

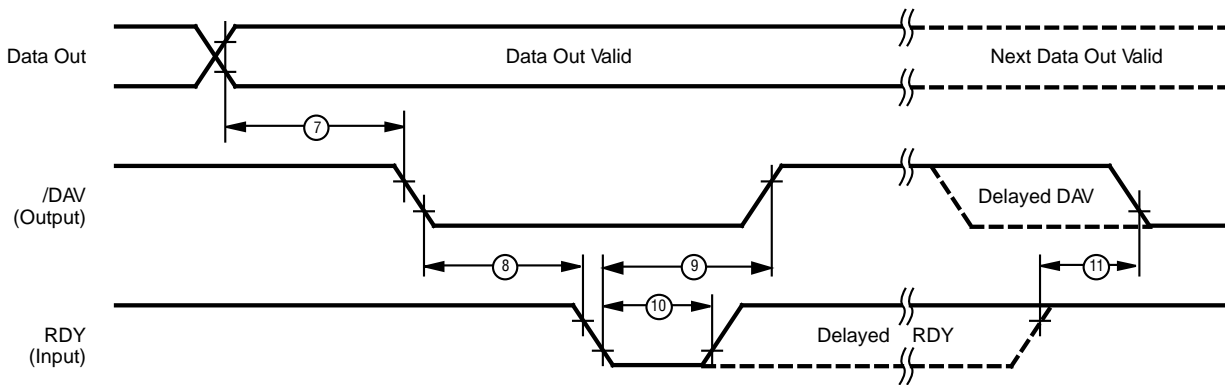

Figure 22. Output Handshake Timing

AC CHARACTERISTICS

Handshake Timing Table

No	Sym	Parameter	$T_A = 0^\circ\text{C to } +70^\circ\text{C}$		$T_A = -40^\circ\text{C to } +105^\circ\text{C}$				Data Direction
			12 MHz	16 MHz	12 MHz	16 MHz	Min	Max	
1	TsDI(DAV)	Data In Setup Time	0	0	0	0			IN
2	ThDI(DAV)	Data In Hold Time	145	145	145	145			IN
3	TwDAV	Data Available Width	110	110	110	110			IN
4	TdDAVI(RDY)	DAV Fall to RDY Fall Delay		115		115	115	115	IN
5	TdDAVIId(RDY)	DAV Rise to RDY Rise Delay		115		115	115	115	IN
6	TdRDYO(DAV)	RDY Rise to DAV Fall Delay	0	0	0	0	0	0	IN
7	TdDO(DAV)	Data Out to DAV Fall Delay		TpC		TpC	TpC	TpC	OUT
8	TdDAVO(RDY)	DAV Fall to RDY Fall Delay	0	0	0	0	0	0	OUT
9	TdRDYO(DAV)	RDY Fall to DAV Rise Delay		115		115	115	115	OUT
10	TwRDY	RDY Width	110	110	110	110	110	110	OUT
11	TdRDYOd(DAV)	RDY Rise to DAV Fall Delay		115		115	115	115	OUT

Z8 CONTROL REGISTER DIAGRAMS

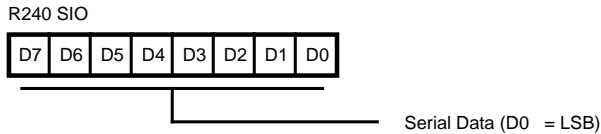

**Figure 23. Serial I/O Register
(F0_H: Read/Write)**

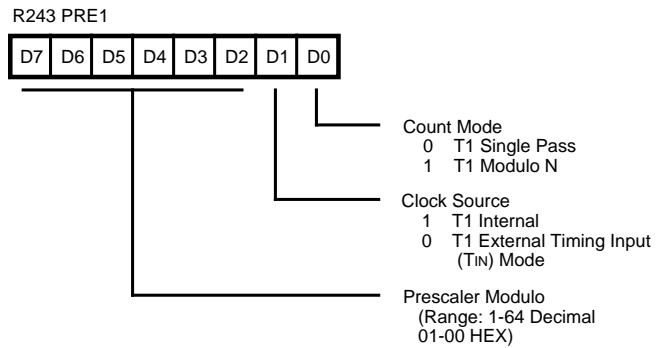

**Figure 26. Prescaler 1 Register
(F3_H: Write Only)**

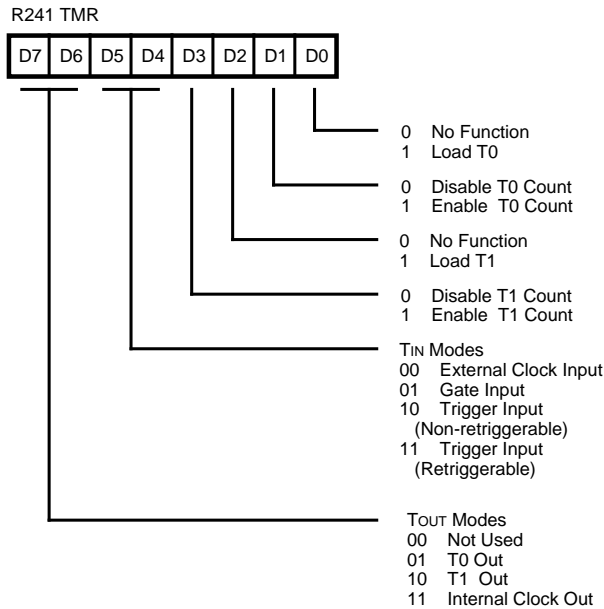

**Figure 24. Timer Mode Register
(F1_H: Read/Write)**

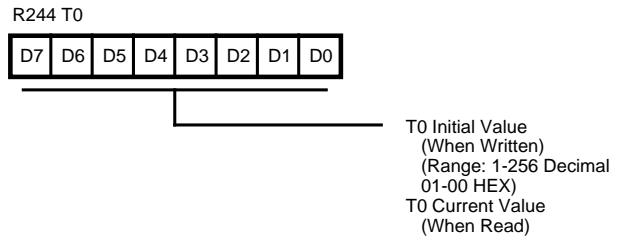

**Figure 27. Counter/Timer 0 Register
(F4_H: Read/Write)**

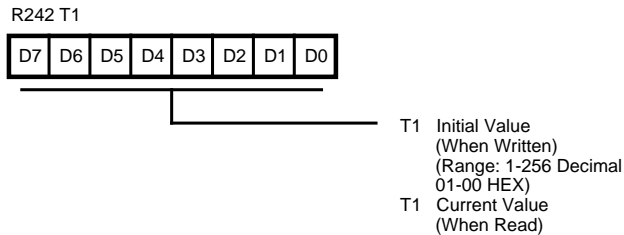

**Figure 25. Counter/Timer 1 Register
(F2_H: Read/Write)**

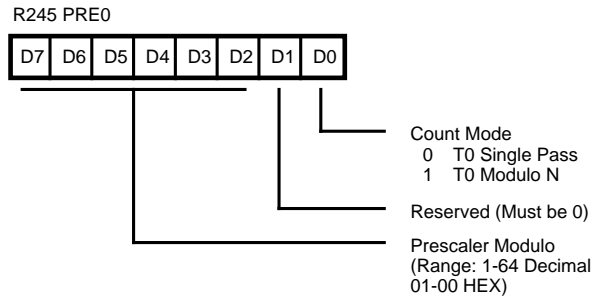

**Figure 28. Prescaler 0 Register
(F5_H: Write Only)**

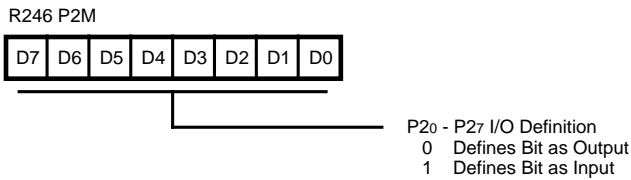

**Figure 29. Port 2 Mode Register
(F6_H: Write Only)**

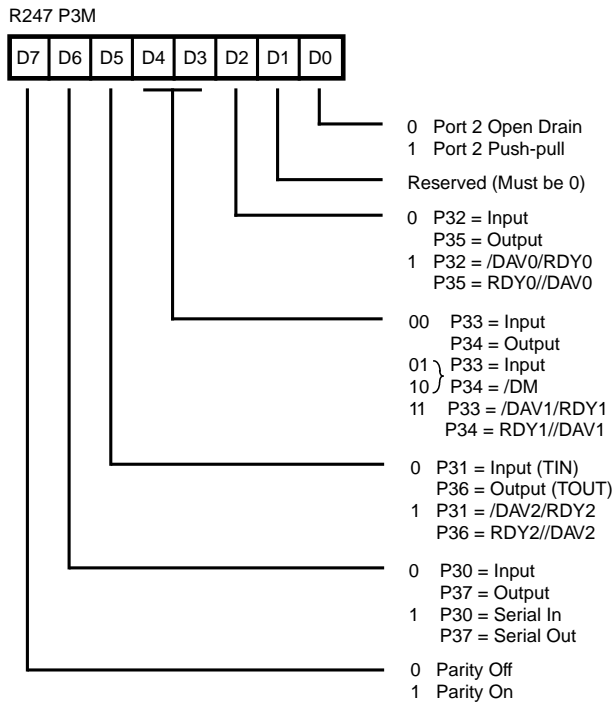

**Figure 30. Port 3 Mode Register
(F7_H: Write Only)**

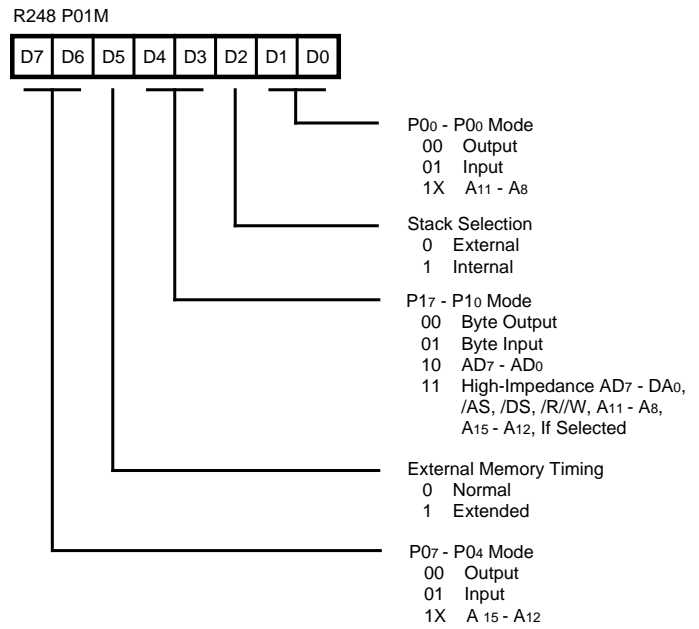

**Figure 31. Port 0 and 1 Mode Register
(F8_H: Write Only)**

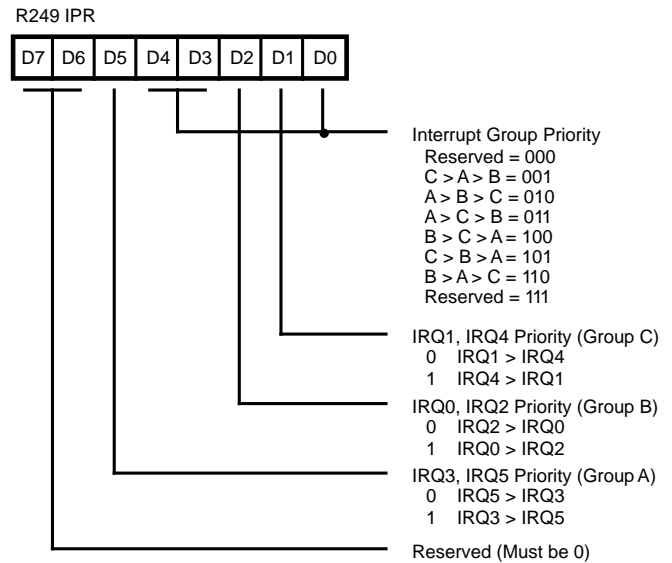

**Figure 32. Interrupt Priority Register
(F9_H: Write Only)**

Z8 CONTROL REGISTER DIAGRAMS (Continued)

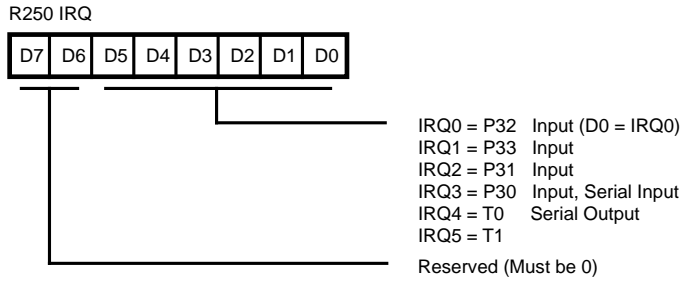

Figure 33. Interrupt Request Register
(FA_H: Read/Write)

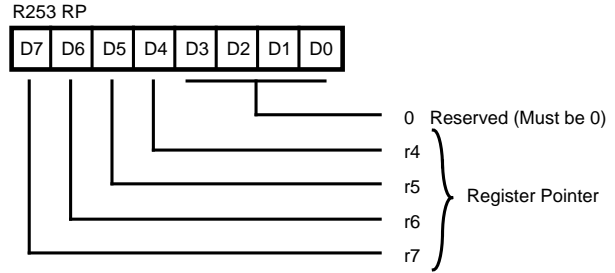

Figure 36. Register Pointer Register
(FD_H: Read/Write)

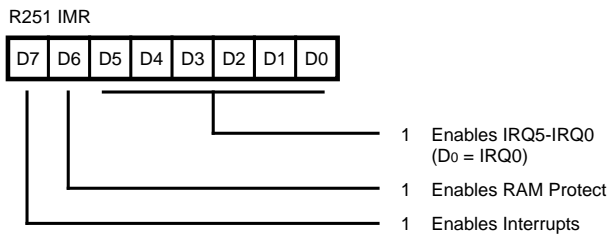

Figure 34. Interrupt Mask Register
(FB_H: Read/Write)

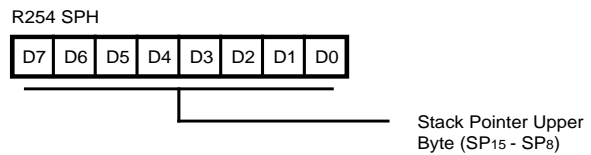

Figure 37. Stack Pointer Register
(FE_H: Read/Write)

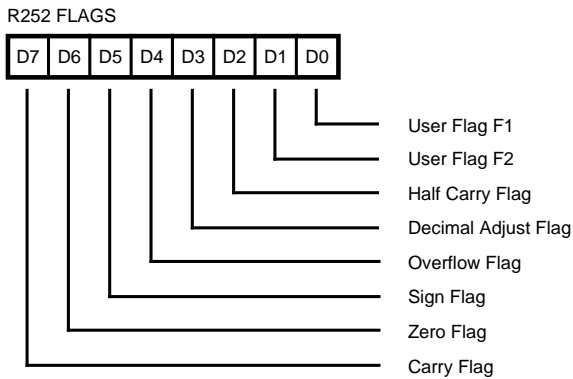

Figure 35. Flag Register
(FC_H: Read/Write)

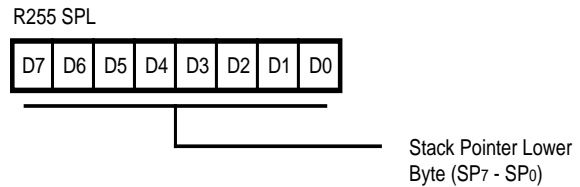

Figure 38. Stack Pointer Register
(FF_H: Read/Write)

INSTRUCTION SET NOTATION

Addressing Modes. The following notation is used to describe the addressing modes and instruction operations as shown in the instruction summary.

Symbol	Meaning
IRR	Indirect register pair or indirect working-register pair address
lrr	Indirect working-register pair only
X	Indexed address
DA	Direct address
RA	Relative address
IM	Immediate
R	Register or working-register address
r	Working-register address only
IR	Indirect-register or indirect working-register address
lr	Indirect working-register address only
RR	Register pair or working register pair address

Symbols. The following symbols are used in describing the instruction set.

Symbol	Meaning
dst	Destination location or contents
src	Source location or contents
cc	Condition code
@	Indirect address prefix
SP	Stack Pointer
PC	Program Counter
FLAGS	Flag register (Control Register 252)
RP	Register Pointer (R253)
IMR	Interrupt mask register (R251)

Flags. Control register (R252) contains the following six flags:

Symbol	Meaning
C	Carry flag
Z	Zero flag
S	Sign flag
V	Overflow flag
D	Decimal-adjust flag
H	Half-carry flag

Affected flags are indicated by:

0	Clear to zero
1	Set to one
*	Set to clear according to operation
-	Unaffected
x	Undefined

CONDITION CODES

Value	Mnemonic	Meaning	Flags Set
1000		Always True	
0111	C	Carry	C = 1
1111	NC	No Carry	C = 0
0110	Z	Zero	Z = 1
1110	NZ	Not Zero	Z = 0
1101	PL	Plus	S = 0
0101	MI	Minus	S = 1
0100	OV	Overflow	V = 1
1100	NOV	No Overflow	V = 0
0110	EQ	Equal	Z = 1
1110	NE	Not Equal	Z = 0
1001	GE	Greater Than or Equal	(S XOR V) = 0
0001	LT	Less than	(S XOR V) = 1
1010	GT	Greater Than	[Z OR (S XOR V)] = 0
0010	LE	Less Than or Equal	[Z OR (S XOR V)] = 1
1111	UGE	Unsigned Greater Than or Equal	C = 0
0111	ULT	Unsigned Less Than	C = 1
1011	UGT	Unsigned Greater Than	(C = 0 AND Z = 0) = 1
0011	ULE	Unsigned Less Than or Equal	(C OR Z) = 1
0000	F	Never True (Always False)	

INSTRUCTION FORMATS



One-Byte Instructions

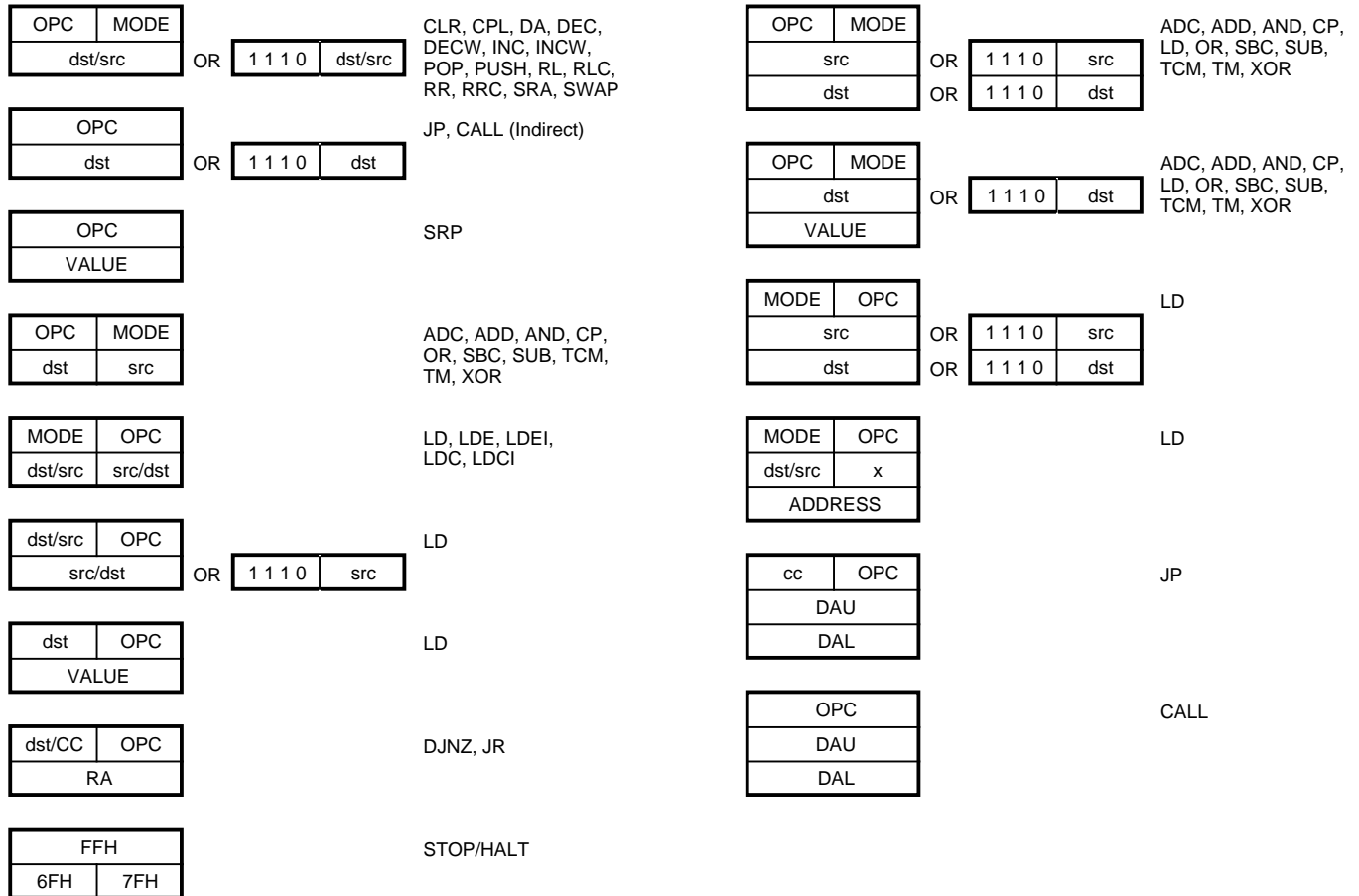

Two-Byte Instructions

Three-Byte Instructions

INSTRUCTION SUMMARY

Note: Assignment of a value is indicated by the symbol “←”. For example:

$$\text{dst} \leftarrow \text{dst} + \text{src}$$

indicates that the source data is added to the destination data and the result is stored in the destination location. The

notation “addr (n)” is used to refer to bit (n) of a given operand location. For example:

$$\text{dst} (7)$$

refers to bit 7 of the destination operand.

INSTRUCTION SUMMARY (Continued)

Instruction and Operation	Address		Opcode Byte (Hex)	Flags Affected						
	Mode	dst src		C	Z	S	V	D	H	
ADC dst, src dst←dst + src + C	†		1[]	*	*	*	*	0	*	
ADD dst, src dst←dst + src	†		0[]	*	*	*	*	0	*	
AND dst, src dst←dst AND src	†		5[]	-	*	*	0	-	-	
CALL dst SP←SP - 2 @SP←PC, PC←dst	DA IRR		D6 D4	-	-	-	-	-	-	
CCF C←NOT C			EF	*	-	-	-	-	-	
CLR dst dst←0	R IR		B0 B1	-	-	-	-	-	-	
COM dst dst←NOT dst	R IR		60 61	-	*	*	0	-	-	
CP dst, src dst - src	†		A[]	*	*	*	*	-	-	
DA dst dst←DA dst	R IR		40 41	*	*	*	X	-	-	
DEC dst dst←dst - 1	R IR		00 01	-	*	*	*	-	-	
DECW dst dst←dst - 1	RR IR		80 81	-	*	*	*	-	-	
DI IMR(7)←0			8F	-	-	-	-	-	-	
DJNZ r, dst r←r - 1 if r ≠ 0 PC←PC + dst Range: +127, -128	RA		rA r = 0 - F	-	-	-	-	-	-	
EI IMR(7)←1			9F	-	-	-	-	-	-	
HALT			7F	-	-	-	-	-	-	
INC dst dst←dst + 1	r R IR		rE r = 0 - F 20 21	-	*	*	*	-	-	
INCW dst dst←dst + 1	RR IR		A0 A1	-	*	*	*	-	-	
IRET FLAGS←@SP; SP←SP + 1 PC←@SP; SP←SP + 2; IMR(7)←1			BF	*	*	*	*	*	*	
JP cc, dst if cc is true PC←dst	DA IRR		cD c = 0 - F 30	-	-	-	-	-	-	
JR cc, dst if cc is true, PC←PC + dst Range: +127, -128	RA		cB c = 0 - F	-	-	-	-	-	-	
LD dst, src dst←src	r r R r X r r R R R R IR IR R	Im R r X r lr r R R R R IM IM R	rC r8 r9 r = 0 - F C7 D7 E3 F3 E4 E5 E6 E7 F5	-	-	-	-	-	-	
LDC dst, src	r	lrr	C2	-	-	-	-	-	-	
LDCI dst, src dst←src r←r + 1; rr←rr + 1	lr	lrr	C3	-	-	-	-	-	-	

INSTRUCTION SUMMARY (Continued)

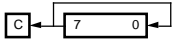
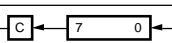
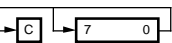
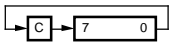
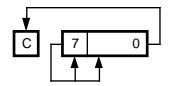
Instruction and Operation	Address Mode		Opcode Byte (Hex)	Flags Affected							
	dst	src		C	Z	S	V	D	H		
NOP			FF	-	-	-	-	-	-	-	-
OR dst, src dst←dst OR src	†		4[]	-	*	*	0	-	-	-	-
POP dst dst←@SP; SP←SP + 1	R		50	-	-	-	-	-	-	-	-
	IR		51								
PUSH src SP←SP - 1; @SP←src		R	70	-	-	-	-	-	-	-	-
		IR	71								
RCF C←0			CF	0	-	-	-	-	-	-	-
RET PC←@SP; SP←SP + 2			AF	-	-	-	-	-	-	-	-
RL dst	R		90	*	*	*	*	*	-	-	-
	IR		91								
RLC dst	R		10	*	*	*	*	*	-	-	-
	IR		11								
RR dst	R		E0	*	*	*	*	*	-	-	-
	IR		E1								
RRC dst	R		C0	*	*	*	*	*	-	-	-
	IR		C1								
SBC dst, src dst←dst←src←C	†		3[]	*	*	*	*	*	1	*	*
SCF C←1			DF	1	-	-	-	-	-	-	-
SRA dst	R		D0	*	*	*	0	-	-	-	-
	IR		D1								
SRP src RP←src		Im	31	-	-	-	-	-	-	-	-

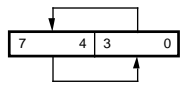
Instruction and Operation	Address Mode		Opcode Byte (Hex)	Flags Affected							
	dst	src		C	Z	S	V	D	H		
STOP			6F	-	-	-	-	-	-	-	-
SUB dst, src dst←dst←src	†		2[]	*	*	*	*	*	1	*	*
SWAP dst	R		F0	X	*	*	X	-	-	-	-
	IR		F1								
TCM dst, src (NOT dst) AND src	†		6[]	-	*	*	0	-	-	-	-
TM dst, src dst AND src	†		7[]	-	*	*	0	-	-	-	-
XOR dst, src dst←dst XOR src	†		B[]	-	*	*	0	-	-	-	-

† These instructions have an identical set of addressing modes, which are encoded for brevity. The first opcode nibble is found in the instruction set table above. The second nibble is expressed symbolically by a '[]' in this table, and its value is found in the following table to the left of the applicable addressing mode pair.

For example, the opcode of an ADC instruction using the addressing modes r (destination) and Ir (source) is 13.

Address Mode		Lower Opcode Nibble
dst	src	
r	r	[2]
r	Ir	[3]
R	R	[4]
R	IR	[5]
R	IM	[6]
IR	IM	[7]

OPCODE MAP

		Lower Nibble (Hex)															
		0	1	2	3	4	5	6	7	8	9	A	B	C	D	E	F
Upper Nibble (Hex)	0	6.5 DEC R1	6.5 DEC IR1	6.5 ADD r1, r2	6.5 ADD r1, lr2	10.5 ADD R2, R1	10.5 ADD IR2, R1	10.5 ADD R1, IM	10.5 ADD IR1, IM	6.5 LD r1, R2	6.5 LD r2, R1	12/10.5 DJNZ r1, RA	12/10.0 JR cc, RA	6.5 LD r1, IM	12.10.0 JP cc, DA	6.5 INC r1	
	1	6.5 RLC R1	6.5 RLC IR1	6.5 ADC r1, r2	6.5 ADC r1, lr2	10.5 ADC R2, R1	10.5 ADC IR2, R1	10.5 ADC R1, IM	10.5 ADC IR1, IM								
	2	6.5 INC R1	6.5 INC IR1	6.5 SUB r1, r2	6.5 SUB r1, lr2	10.5 SUB R2, R1	10.5 SUB IR2, R1	10.5 SUB R1, IM	10.5 SUB IR1, IM								
	3	8.0 JP IRR1	6.1 SRP IM	6.5 SBC r1, r2	6.5 SBC r1, lr2	10.5 SBC R2, R1	10.5 SBC IR2, R1	10.5 SBC R1, IM	10.5 SBC IR1, IM								
	4	8.5 DA R1	8.5 DA IR1	6.5 OR r1, r2	6.5 OR r1, lr2	10.5 OR R2, R1	10.5 OR IR2, R1	10.5 OR R1, IM	10.5 OR IR1, IM								
	5	10.5 POP R1	10.5 POP IR1	6.5 AND r1, r2	6.5 AND r1, lr2	10.5 AND R2, R1	10.5 AND IR2, R1	10.5 AND R1, IM	10.5 AND IR1, IM								
	6	6.5 COM R1	6.5 COM IR1	6.5 TCM r1, r2	6.5 TCM r1, lr2	10.5 TCM R2, R1	10.5 TCM IR2, R1	10.5 TCM R1, IM	10.5 TCM IR1, IM								6.0 STOP
	7	10/12.1 PUSH R2	12/14.1 PUSH IR2	6.5 TM r1, r2	6.5 TM r1, lr2	10.5 TM R2, R1	10.5 TM IR2, R1	10.5 TM R1, IM	10.5 TM IR1, IM								7.0 HALT
	8	10.5 DECW RR1	10.5 DECW IR1	12.0 LDE r1, lrr2	18.0 LDEI lr1, lrr2												6.1 DI
	9	6.5 RL R1	6.5 RL IR1	12.0 LDE r2, lrr1	18.0 LDEI lr2, lrr1												6.1 EI
	A	10.5 INCW RR1	10.5 INCW IR1	6.5 CP r1, r2	6.5 CP r1, lr2	10.5 CP R2, R1	10.5 CP IR2, R1	10.5 CP R1, IM	10.5 CP IR1, IM								14.0 RET
	B	6.5 CLR R1	6.5 CLR IR1	6.5 XOR r1, r2	6.5 XOR r1, lr2	10.5 XOR R2, R1	10.5 XOR IR2, R1	10.5 XOR R1, IM	10.5 XOR IR1, IM								16.0 IRET
	C	6.5 RRC R1	6.5 RRC IR1	12.0 LDC r1, lrr2	18.0 LDCI lr1, lrr2				10.5 LD r1,x,R2								6.5 RCF
	D	6.5 SRA R1	6.5 SRA IR1	12.0 LDC r1, lrr2	18.0 LDCI lr1, lrr2	20.0 CALL* IRR1		20.0 CALL DA	10.5 LD r2,x,R1								6.5 SCF
	E	6.5 RR R1	6.5 RR IR1		6.5 LD r1, IR2	10.5 LD R2, R1	10.5 LD IR2, R1	10.5 LD R1, IM	10.5 LD IR1, IM								6.5 CCF
	F	8.5 SWAP R1	8.5 SWAP IR1		6.5 LD lr1, r2		10.5 LD R2, IR1										6.0 NOP

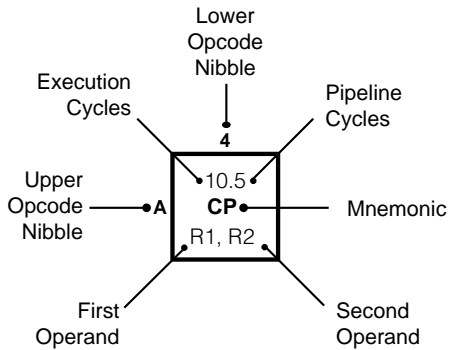
Legend:

- R = 8-bit Address
- r = 4-bit Address
- R1 or r1 = Dst Address
- R2 or r2 = Src Address

Sequence:

Opcode, First Operand, Second Operand

Note: Blank areas not defined.

*2-byte instruction appears as a 3-byte instruction

PACKAGE INFORMATION

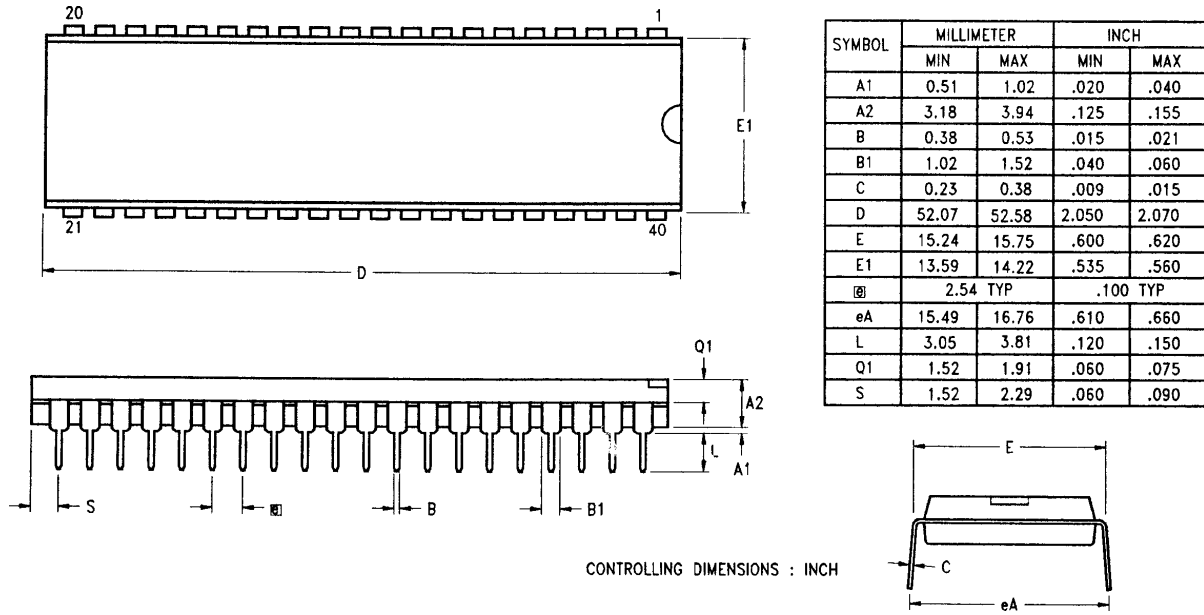

40-Pin PDIP Package Diagram

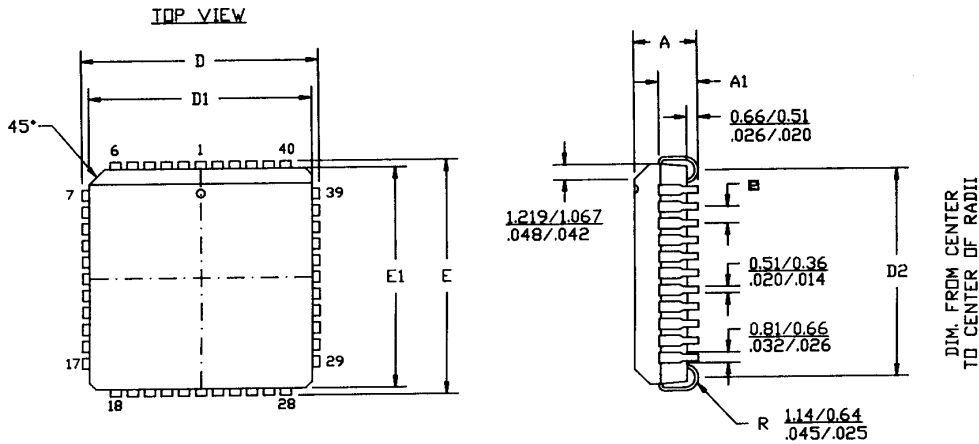

- NOTES:
1. CONTROLLING DIMENSIONS : INCH
 2. LEADS ARE COPLANAR WITHIN .004 IN.
 3. DIMENSION : $\frac{MM}{INCH}$

44-Pin PLCC Package Diagram

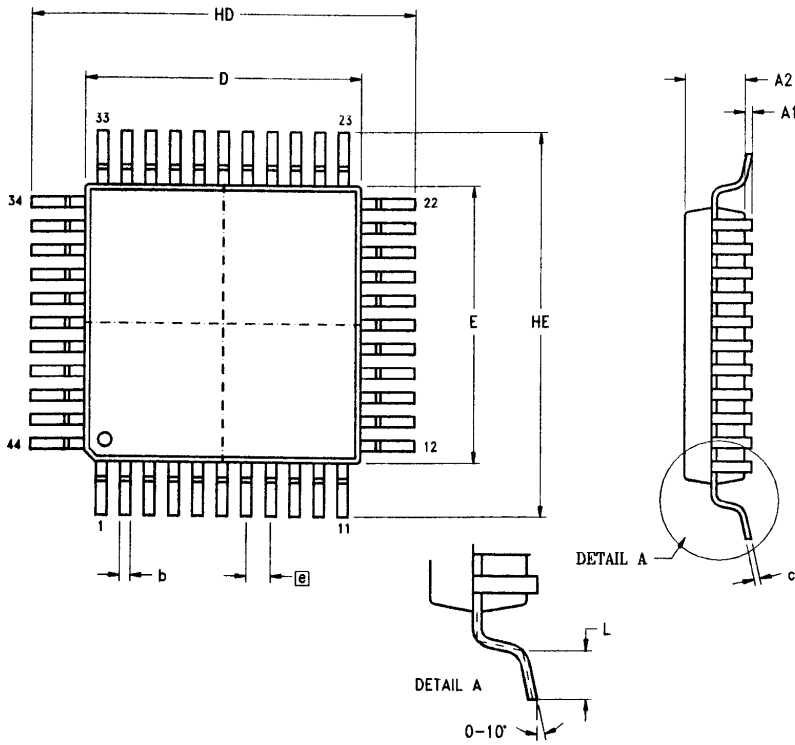
PACKAGE INFORMATION (Continued)

SYMBOL	MILLIMETER		INCH	
	MIN	MAX	MIN	MAX
A1	0.05	0.25	.002	.010
A2	2.00	2.25	.078	.089
b	0.25	0.45	.010	.018
c	0.13	0.20	.005	.008
HD	13.70	14.15	.539	.557
D	9.90	10.10	.390	.398
HE	13.70	14.15	.539	.557
E	9.90	10.10	.390	.398
Ⓜ	0.80 TYP		.0315 TYP	
L	0.60	1.20	.024	.047

NOTES:
 1. CONTROLLING DIMENSIONS : MILLIMETER
 2. LEAD COPLANARITY : MAX $\frac{.10}{.004}$ "

44-Pin QFP Package Diagram

ORDERING INFORMATION

Z86C21

12 MHz

40-pin DIP

Z86C2112PSC

Z86C2112PEC

44-pin PLCC

Z86C2112VSC

Z86C2112VEC

44-pin QFP

Z86C2112FSC

Z86C2112FEC

16 MHz

40-pin DIP

Z86C2116PSC

44-pin PLCC

Z86C2116VSC

44-pin QFP

Z86C2116FSC

For fast results, contact your local Zilog Sales Office for assistance in ordering the part desired.

CODES

Preferred Package

P = Plastic DIP

V = Plastic Chip Carrier

Longer Lead Time

F = Plastic Quad Flat Pack

Preferred Temperature

S = 0°C to +70°C

Longer Lead Time

E = -40°C to +105°C

Speeds

12 = 12 MHz

16 = 16 MHz

Environmental

C = Plastic Standard

Example:

Z 89C21 12 P S C is a Z89C21, 12 MHz, DIP, 0°C to +70°C, Plastic Standard Flow

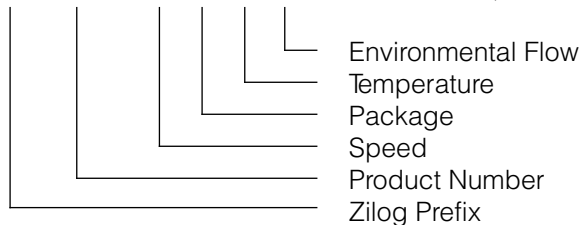

© 1995 by Zilog, Inc. All rights reserved. No part of this document may be copied or reproduced in any form or by any means without the prior written consent of Zilog, Inc. The information in this document is subject to change without notice. Devices sold by Zilog, Inc. are covered by warranty and patent indemnification provisions appearing in Zilog, Inc. Terms and Conditions of Sale only. Zilog, Inc. makes no warranty, express, statutory, implied or by description, regarding the information set forth herein or regarding the freedom of the described devices from intellectual property infringement. Zilog, Inc. makes no warranty of merchantability or fitness for any purpose. Zilog, Inc. shall not be responsible for any errors that may appear in this document. Zilog, Inc. makes no commitment to update or keep current the information contained in this document.

Zilog's products are not authorized for use as critical components in life support devices or systems unless a specific written agreement pertaining to such intended use is executed between the customer and Zilog prior to use. Life support devices or systems are those which are intended for surgical implantation into the body, or which sustains life whose failure to perform, when properly used in accordance with instructions for use provided in the labeling, can be reasonably expected to result in significant injury to the user.

Zilog, Inc. 210 East Hacienda Ave.
Campbell, CA 95008-6600
Telephone (408) 370-8000
Telex 910-338-7621
FAX 408 370-8056
Internet: <http://www.zilog.com>