

Introduction

Key Features

- IEEE 802.15.4 compliant
- ISM band transceiver with RF and baseband
- Direct Sequence Spread Spectrum (DSSS)
- Burst data rate 20kbit/s (EU), 40kbit/s (US)
- Transmit range up to 100 meter (LoS)
- Low power for battery operated devices
- SPI and Parallel interfaces
- Compliant PHY and Thin MAC
- Available in 48-lead QFN (7mm X 7mm) package

Description

The ZMD44101 is a fully integrated system-on-chip CMOS transceiver, providing license free multi-channel operation in the 868.3MHz (EU) and 902MHz to 928MHz (US) ISM bands. The low power baseband transceiver is optimized for data rates up to 40kbp/s and incorporates direct sequence spread spectrum technology to assure reliable data transfer in hostile RF environments. The high level of integration, shown below, includes a thin Media Access Controller, resulting in a minimum of external components and lower application costs.

Operating Reference Data

Temperature Range.....-40°C to +85°C
 Supply Voltage, V_{DD}.....+2.4 V
 Typical Supply Current (Tx active).....32mA
 Typical Supply Current (Rx active).....28mA
 Typical Supply Current (sleep mode).....2µA
 Frequency Range.....868MHz to 928MHz

Applications

- Energy Management
- Remote Metering and Control
- Home and Building Control
- Industrial Networks
- Remote Keyless Entry (two-way)
- Health Monitor Networking

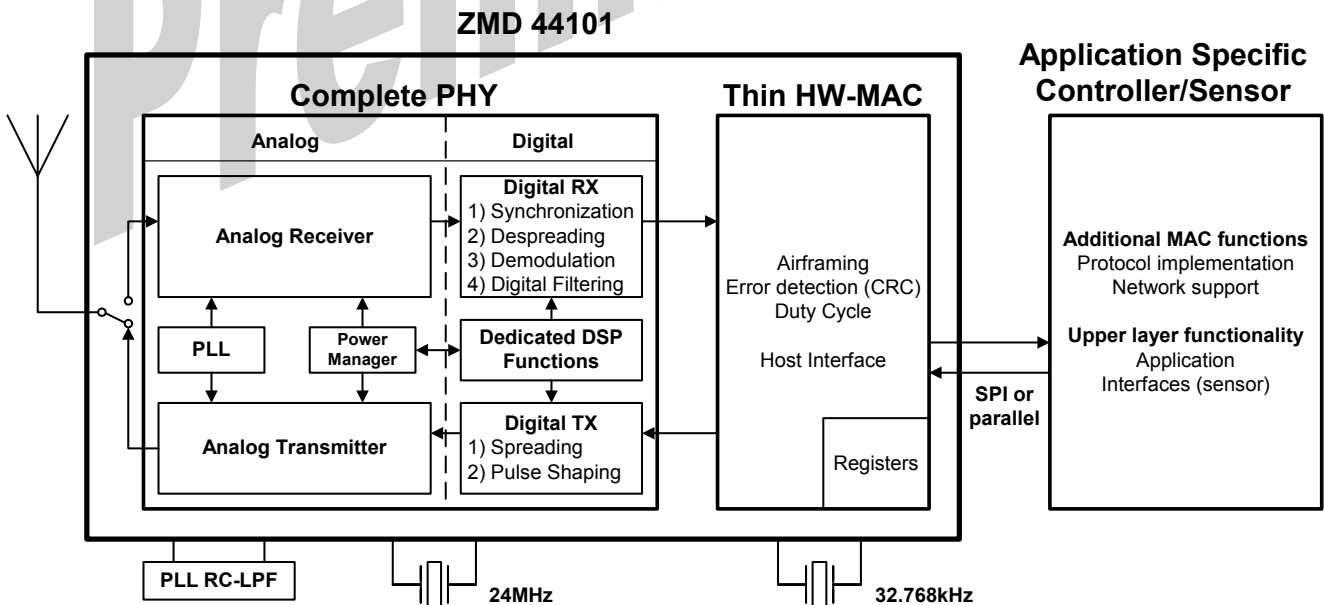

Table of Contents

1	Pin Diagram	3
2	General Device Specifications	4
2.1	Absolute Maximum Ratings	4
2.2	Recommended Operating Conditions	4
2.3	D.C. Electrical Characteristics	4
2.4	Digital I/O	5
3	A.C. Electrical Characteristics	5
3.1	General	5
3.2	Startup time	5
4	Interfaces	6
4.1	Overview	6
4.2	Serial Peripheral Interface (SPI)	7
4.2.1	SPI Configuration	7
4.3	Parallel Interface	9
5	Registers	10
5.1	MAC control + status register	10
5.2	MAC timing registers	11
5.3	Other MAC registers	12
5.4	MAC header registers	13
5.5	PHY registers	13
6	Application circuit – external components	14
7	ZMD44101 System Performance Summary	15
8	System Description	16
8.1	General Block Diagram	16
8.2	Receiver Chain	17
8.2.1	RAGCL - AGC Level Register	18
8.3	Transmitter Chain	18
8.3.1	RTXM - Transmitter Mode Register	18
8.4	RF Phase Locked Loop	19
8.5	Reference Crystal Oscillator (24MHz)	20
8.6	Low Power Crystal Oscillator (32.768kHz)	21
8.7	CLKO - Clock Output Configuration	21
8.8	Power Management	22
9	Mechanical Specifications	23
9.1	Package	23
10	List of abbreviations	25
11	References	25

1 Pin Diagram

Figure 1.1 provides the pin layout for the ZMD44101 and Table 1.1 the description of the respective pins.

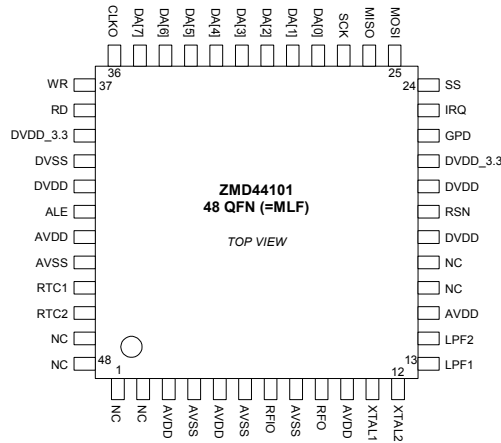

Figure 1.1 - Pin Layout

Pin No.	Pin Name	Pin Type	Description
1	NC	-	No connection
2	NC	-	No connection
3	AVDD	AVDD	Analog power supply
4	AVSS	Ground	Analog ground
5	AVDD	AVDD	RF power supply
6	AVSS	Ground	RF ground
7	RFIO	RF IO	RF receiver input and transmitter output
8	AVSS	Ground	RF ground
9	RFO	RF Output	RF transmitter output
10	AVDD	AVDD	Analog PLL power supply
11	XTAL1	Analog Input	24MHz crystal oscillator input
12	XTAL2	Analog Output	24MHz crystal oscillator output
13	LPF1	Analog Output	Loop filter, charge-pump node
14	LPF2	Analog Input	Loop filter, VCO tune node
15	AVDD	AVDD	Analog PLL VCO power supply
16	NC	-	No connection
17	NC	-	No connection
18	DVDD	DVDD	Digital PLL power supply
19	RSN	CMOS Input	Asynchronous chip reset (low - active)
20	DVDD	DVDD	Digital core 2.4V power supply (core and pre-driver)
21	DVDD_3.3	DVDD_3.3	Digital IO 3.3V power supply (post-driver)
22	GPD	CMOS IO	Global Power Down (from external device)(h-active)
23	IRQ	CMOS Output	Interrupt (to external device)(low active)
24	SS	CMOS IO	SPI interface - slave select

Pin No.	Pin Name	Pin Type	Description
25	MOSI	CMOS IO	SPI interface - master out, slave in
26	MISO	CMOS IO	SPI interface - master in, slave out
27	SCK	CMOS IO	SPI interface - serial clock
28	DA0	CMOS IO	Data address
29	DA1	CMOS IO	Data address
30	DA2	CMOS IO	Data address
31	DA3	CMOS IO	Data address
32	DA4	CMOS IO	Data address
33	DA5	CMOS IO	Data address
34	DA6	CMOS IO	Data address
35	DA7	CMOS IO	Data address
36	CLKO	CMOS Output	Clock (to external device)
37	WR	CMOS IO	Write data address
38	RD	CMOS IO	Read data address
39	DVDD_3.3	DVDD_3.3	Digital IO 3.3V power supply (post-driver)
40	DVSS	Ground	Digital ground
41	DVDD	DVDD	Digital core 2.4V power supply (core and pre-driver)
42	ALE	CMOS IO	Address latch enable
43	AVDD	AVDD	Analog power supply
44	AVSS	Ground	Analog ground
45	RTC1	Analog Input	32.768kHz crystal oscillator input
46	RTC2	Analog Output	32.768kHz crystal oscillator output
47	NC	-	No Connection
48	NC	-	No Connection

Table 1.1 - Pin Descriptions

2 General Device Specifications

Electrical characteristics over full range of operating conditions, typical values are AVDD, DVDD = 2.4V, DVDD_3.3 = 3.3 V, T_a = 25°C, unless otherwise noted.

2.1 Absolute Maximum Ratings

Caution: Operation beyond these values may cause permanent damage to the device or decrease in reliability. Note: Values are over free-air temperature unless otherwise noted.

Parameter	Symbol	Min	Typ	Max	Unit	Notes
Analog Supply Voltage	AVDD	-	-	3.5	V	
Digital Supply Voltage	DVDD	-	-	3.5	V	
Digital IO Supply Voltage	DVDD_3.3	-	-	4.6	V	
Input Voltage	V _i	-	-	6	V	at CMOS IO
Output Voltage	V _o	-	-	4.6	V	at CMOS IO
Analog Input Voltage	V _{ana}	-	-	3.5	V	at analog IO
Input RF Level	P _{in}	-	-	20	dBm	
Storage Temperature	T _{strg}	-65	-	150	°C	
ESD Protection	V _{esd}	-	-	2	kV	HBM (100pF, 1.5kΩ)

2.2 Recommended Operating Conditions

Parameter	Symbol	Min	Typ	Max	Unit	Notes
Analog Supply Voltage	AVDD	2.2	2.4	2.7	V	
Digital Supply Voltage	DVDD	2.2	2.4	2.7	V	
Digital IO Supply Voltage	DVDD_3.3	3.0	3.3	3.6	V	
Ambient Temperature	T _a	-40	+27	+85	°C	Industrial range
Frequency of Operation	f _{op}	860		930	MHz	868.3MHz (EU), 902MHz to 928MHz (US)

2.3 D.C. Electrical Characteristics

Note: Values are for supply current.

Parameter	Symbol	Min	Typ	Max	Unit
Sleep mode (32kHz crystal and timer on)	I _{dd}	-	2	-	μA
Idle mode (24MHz crystal on)	I _{dd}	-	1	-	mA
Transmit mode	I _{dd}	-	32	-	mA
Receive mode, synchronization	I _{dd}	-	31	-	mA
Receive mode, normal	I _{dd}	-	28	-	mA

2.4 Digital I/O

Module	Symbol	Min	Typ	Max	Unit	Notes
CMOS Input	V_{IL}	-0.3		0.8	V	
	V_{IH}	2		5.5	V	
CMOS Output	V_{OL}			0.4	V	
	V_{OH}	2.4			V	

3 A.C. Electrical Characteristics

Electrical characteristics over full range of operating conditions, typical values are AVDD, DVDD = 2.4V, DVDD_3.3 = 3.3 V, TA = 25°C, unless otherwise noted.

3.1 General

Symbol	Min	Typ	Max	Unit	Note
Transmitter					
P_{out}	-3	0	3	dBm	output power at 50Ω
P_{low1}		-7		dBm	low output power mode 1
P_{low2}		-14		dBm	low output power mode 2
P_{low3}		-21		dBm	low output power mode 3
P_{SL}			-30	dBm	max. spurious emission=1 st side lobe
Harmonics			-35	dBm	
P_N			-57	dBm	Standby radiation
r_{EU}		300		kBit/s	Chip rate (EU) @ channel 0
r_{US}		600		kBit/s	Chip rate (US) @ channel 1 to 10
Receiver					
P_{min}	-100			dBm	at packet error rate (PER) <1%
NF		10		dB	
$P_{in,max}$		-20		dBm	maximum usable input power
IIP3		-20		dBm	
IIP2		25		dBm	
LO leakage			-57	dBm	
PLL					
bandwidth	860		930	MHz	
f_{ref}		24		MHz	crystal with 32pF C_{load} =32pF
BW_{LPF}		300		kHz	LPF bandwidth
f_{res}		732		Hz	frequency resolution
f_{cs}		2		MHz	channel spacing for IEEE 802.15.4
Φ_N			-85	dBc	(10... 100) kHz offset

3.2 Startup time

Parameter	Time	Unit
Power on to idle mode	1.0 (typical)	ms
Idle mode to Transmitter ready	0.18	ms
Idle mode to Receiver ready	0.2	ms
Receiver to Transmitter turnaround	0.2	ms
Transmitter to Receiver turnaround	0.2	ms

4 Interfaces

4.1 Overview

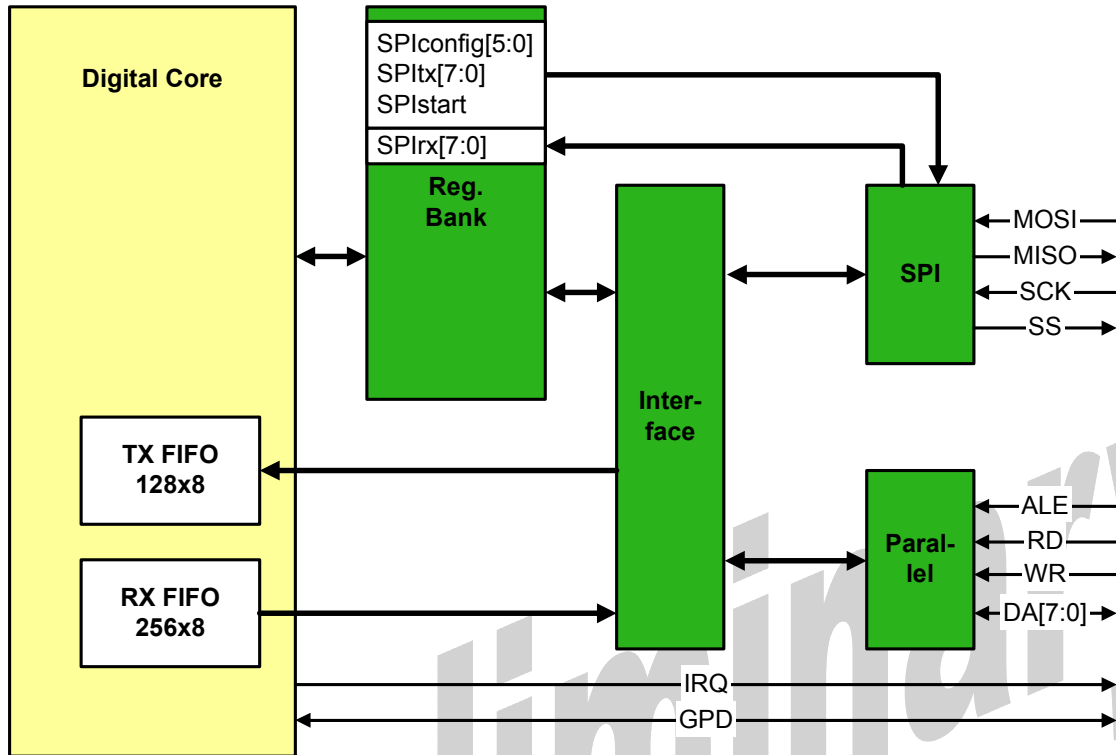

Figure 4-1: Interface Block Diagram

The ZMD44101 provides a parallel interface and an SPI to access the internal register bank, the TX and the RX FIFO. Additionally it has an IRQ output and a dedicated global power down (GPD) input. By default both interfaces the parallel and the SPI as slave are available. For proper operation the unused interface shall be disabled. The parallel interface is disabled by setting RD,WR, and ALE to high, putting the DataAddress[7:0] bus into High-Z state. The SPI is disabled by setting SS to high.

The SPI can also be configured as master. In the master setup it behaves like a remote interface which can be controlled by the external microcontroller via the ZMD44101 parallel interface and some SPI control register in the register bank.

4.2 Serial Peripheral Interface (SPI)

4.2.1 SPI Configuration

The SPI is configured via the SPIconfig (R/W) register.

A standard based SPI is used by default in slave mode. Certain registers can switch the interface to master mode to work with another slave. In that case the parallel microcontroller interface is used to control the ZMD44101. The interface provides the standard lines MISO, MOSI, SCK and SS. For Write Access the first bit of the first byte on MOSI has to be '0'. For Read Access the first bit of the first byte written to MOSI has to be '1'. SS (Slave Select) has to be '0' when accessing the ZMD44101 through the SPI.

The ZMD44101 uses a data transfer protocol allowing single and multiple byte read/write access. All bytes are transmitted with the MSB first and the LSB last.

The protocol always starts by writing 2 bytes to the SPI slave via the MOSI line. The MSB of the first byte is the read/write indicator. A high bit stands for read access and a low bit for write access. The read/write bit is followed by the length[6:0] descriptor N. It controls the length of the data frame $D_0[7:0]$ to $D_{N-1}[7:0]$. N has to be in a range 1 to 127. The second byte is the address[7:0]. For TX/RX FIFO access the address are 0x80 and 0x81 respectively. Note that the TX FIFO only allows write access and the RX FIFO read access. In the case of register bank access a number of N bytes is read starting from address[7:0] up to address[7:0]+(N-1). In the case the FIFO locations 0x80 or 0x81 are within this range they are skipped and the read/write access is continued at location 0x82.

For write access the address[7:0] byte is followed by the data frame $D_0[7:0]$ to $D_{N-1}[7:0]$. In figure 4-2 the slave select signal SS is low during the complete write transfer. However it is also allowed to insert SS high gaps between each byte.

In the read access protocol the data frame is shifted out by the slave on the MISO line. Before each data byte a SS high gap is required. Similar to the write access a SS high gap can be inserted before the address[7:0] byte.

Timing parameters are listed in the following table.

Parameter	Description	US mode		EU mode	
		min	max	min	max
tcp	SCK clock period	0.50 μ s		1.00 μ s	
tsc	SS low to SCK active edge	0.25 μ s		0.50 μ s	
tss	SS high pulse with	1.00 μ s		2.00 μ s	

write access:

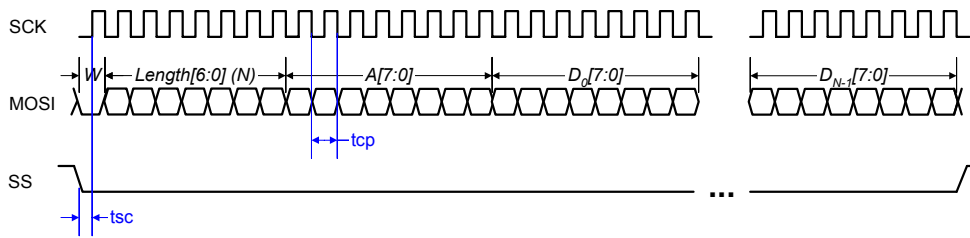

read access:

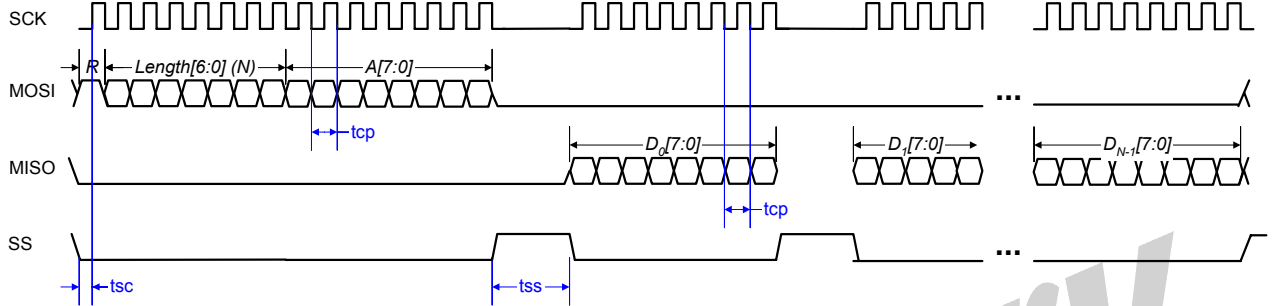

Figure 4-2: Transfer Protocol (SPI Slave Mode), CPHA=0 CPOL=0

Preliminary

4.3 Parallel Interface

The parallel interface consists of the bi-directional DataAddress[7:0] bus and the control inputs read (RD), write (WR) and address latch enable (ALE). The direction of the DA[7:0] bus is controlled by the RD input. If RD is high DA[7:0] are in input mode. Setting RD low turns DA[7:0] into output direction. The timing diagram for read and write access is shown below.

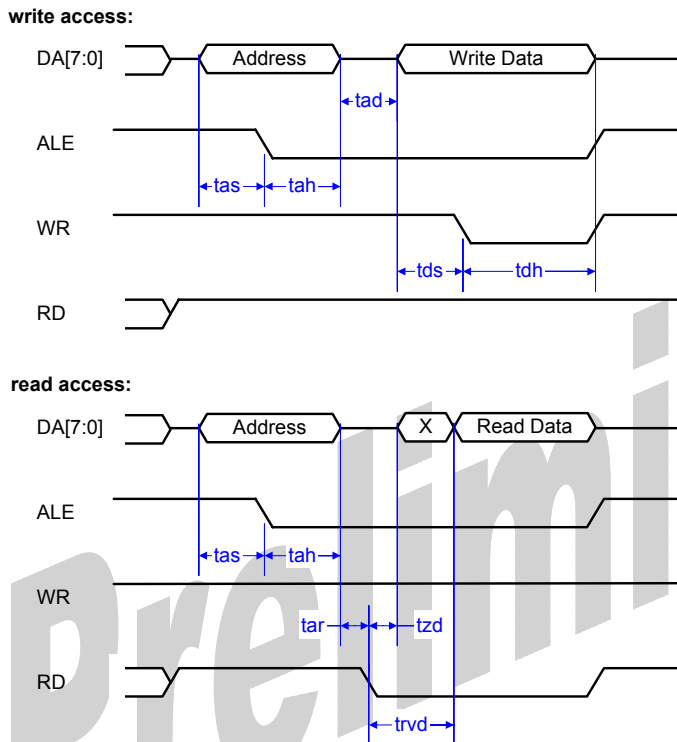

Figure 4-2: Parallel Interface Read/Write Access

Timing parameters are listed in the following table.

Parameter	Description	US mode		EU mode	
		min	max	min	max
tas	address setup time	0		0	
tah	address hold time	200 ns		200 ns	
tad	address to data time	0		0	
tds	data setup time	0		0	
tdh	data hold time	300 us		600 us	
tar	address to RD low time	0		0	
tzd	high-z to data time	0	10 ns	0	10 ns
trvd	read low to valid data		400 us		800 us

5 Registers

The ZMD44101 has several registers for MAC and PHY functional support. The register description shall give a brief overview only. A more detailed description can be found in the users manual. The registers are accessible through the two interface ports. The Hardware-MAC registers provide a great advantage for system implementation in comparison to a MAC implementation in a microcontroller only. Especially many system timing critical functions are implemented in the ZMD44101. Most registers can be referred to in the IEEE802.15.4 standard.

5.1 MAC control + status register

Addr	Register name	bits	type	default	description
8'hE0	IRQreason	8	RW	0	interrupt reason
8'hE1	IRQmask1	8	RW	8'h00	interrupt mask[7:0]
8'hE2	IRQmask2	8	RW	8'h00	interrupt mask[15:8]
8'hE3	IRQmask3	7	RW	7'h00	interrupt mask[22:16]
8'hE4	SPIconfig	6	RWI	6'h20	SPI configuration register
8'hE5	SPIstart	1	RWS	0	SPI start (master mode)
8'hE6	SPItx	8	RW	0	SPI transmit byte (master mode)
8'hE7	SPIrx	8	R	0	SPI receive byte (master mode)
8'hE8	ClkOutConfig	8	RW	8'h29	CLKO pad configuration (def: normal mode = 24Mhz/4, sleep mode = 32.768kHz)
8'hF0	macControl	5	RW	5'h1F	MAC control command used by firmware to control the HW-MAC fsm transitions this control word is cleared by the internal logic after it was fetched 8'hF3
8'hF1	macTxConfig	4	RW	4'h2	MAC transmit mode configuration
8'hF2	macRxConfig	6	RW	6'h1A	MAC rx mode configuration
8'hF3	macBcTrConfig	4	RW	4'h1	MAC beacon track mode configuration
8'hF4	macScanMode	2	RW	0	MAC scan mode (ed, passive, active, orphan)
8'hF5	macOpMode	4	R	0	MAC operating mode status register
8'hF6	macTxStatus	7	R	0	MAC transmit status register
8'hF7	macRxStatus	8	R	0	MAC rx status register
8'hF8	macScanStatus	8	R	0	MAC scan status register
8'hF9	macBcTrStatus	4	R	0	MAC beacon track status register
8'hFA	macAutoBcTxStatus	3	R	0	MAC auto beacon tx status register
8'hFB	macFifoStatus	4	R	0	MAC tx/rx fifo status register

5.2 MAC timing registers

Addr	Register Name	bits	type	default	description
8'hC0	T_RxDefer1	8	RW	8'h00	rx defer time [7:0]
8'hC1	T_RxDefer2	8	RW	8'h00	rx defer time [15:8]
8'hC2	T_RxDefer3	8	RW	8'h00	rx defer time [23:16]
8'hC9	T_ScanDuration1	8	RW	8'h00	scan duration (960*2 ⁵) [7:0]
8'hDA	T_ScanDuration2	8	RW	8'h78	scan duration (960*2 ⁵) [15:8]
8'hCB	T_ScanDuration3	8	RW	8'h00	scan duration (960*2 ⁵) [23:16]
8'hCC	T_BeaconInterval1	8	RW	8'h00	beacon interval (960*2 ⁵) [7:0]
8'hCD	T_BeaconInterval2	8	RW	8'h78	beacon interval (960*2 ⁵) [15:8]
8'hCE	T_BeaconInterval3	8	RW	8'h00	beacon interval (960*2 ⁵) [23:16]
8'hCF	Td_BeaconInterval	4	RW	4'h4	T_delta beacon interval generate IRQ 2 ^{Td_BeaconInterval} before next beacon
8'hD0	T_BeaconScanDuration1	8	RW	8'h00	beacon scan duration (960*2 ⁶) [7:0]
8'hD1	T_BeaconScanDuration2	8	RW	8'hF0	beacon scan duration (960*2 ⁶) [15:8]
8'hD2	T_BeaconScanDuration3	8	RW	8'h00	beacon scan duration (960*2 ⁶) [23:16]
8'hD3	T_BeaconScanStart1	8	RW	8'h0A	beacon scan start (symbols before beacon interval end) (10) [7:0]
8'hD4	T_BeaconScanStart2	3	RW	3'h0	beacon scan start (symbols before beacon interval end) (10) [10:8]
8'hD5	T_Sleep1	8	RW	8'h00	sleep time [7:0]
8'hD6	T_Sleep2	8	RW	8'h00	sleep time [15:8]
8'hD7	T_Sleep3	8	RW	8'h00	sleep time [23:16]
8'hD8	Tdelta1	8	RW	0	superframe timing deviation between RFD and FFD [7:0]
8'hD9	Tdelta2	3	RW	0	superframe timing deviation between RFD and FFD [10:8] used as additional guard time in CAP/GTS check
8'hDA	SFalignOrder	4	RW	4'h0C	superframe timing alignment order the RFD superframe timer is aligned to the estimated FFD timing every 60*2 ^{SFalignOrder} symbols (12)

5.3 Other MAC registers

Addr	Register name	bits	type	default	description
8'h9D	msduLengthTx	7	RW	0	MAC payload (msdu) length (Tx)
8'hA0	mhrFc1Rx	8	R	0	MAC header frame control byte 1 (Rx - last received frame)
8'hA1	mhrFc2Rx	8	R	0	MAC header frame control byte 2 (Rx - last received frame)
8'hA2	mhrSquNbRx	8	R	0	MAC header sequence number (Rx - last received frame)
8'hA3	mpduLengthRx	7	R	0	mpdu length (Rx - last received frame)
8'hA6	macFramePend	6	RW	0	number of frames pending in Rx FIFO queue, reset by software
8'hA7	macSuperframeOrder	4	RW	5	MAC superframe order (SO)
8'hA8	macCAPend	4	RW	15	last slot in CAP
8'hA9	macGTSstart	4	RW	10	1st slot of the GTS
8'hAA	macGTSlength	4	RW	0	GTS length in slots (zero no GTS)
8'hAB	macTotalTimeFFD1	8	R	0	current totaltime [7:0] (FFD mode) in multiple of 32kHz clock
8'hAC	macTotalTimeFFD2	8	R	0	current totaltime [15:8] (FFD mode)
8'hAD	macTotalTimeFFD3	8	R	0	current totaltime [23:16] (FFD mode)
8'hAE	macTotalTimeRFD1	8	R	0	current totaltime [7:0] (RFD mode)
8'hAF	macTotalTimeRFD2	8	R	0	current totaltime [15:8] (RFD mode)
8'hB0	macTotalTimeRFD3	8	R	0	current totaltime [23:16] (RFD mode)
8'hB1	macCurrentSymbolTime1	8	R	0	current superframe time [7:0]
8'hB2	macCurrentSymbolTime2	8	R	0	current superframe time [15:8]
8'hB3	macCurrentSymbolTime3	8	R	0	current superframe time [23:16]
8'hB4	MacCurrent Slot	4	R	0	current slot
8'hB5	macBeaconRxTime1	8	R	0	timestamp[7:0] of the last received beacon
8'hB6	macBeaconRxTime2	5	R	0	timestamp[12:8] of the last received beacon
8'hB7	macScanED	8	R	0	maximum ED value from the ED scan
8'hBE	macMaxLostBeacons	4	RW	4	number of max lost beacons before a SyncLoss is indicated
8'hBF	macSyncLoss	4	R	4	number of lost beacons
8'h75	CRCfail1	8	R	0	number of CRC failures [7:0]
8'h76	CRCfail2	6	R	0	number of CRC failures [13:8]
8'h77	FrameRxCount1	8	R	0	number of received frames [7:0]
8'h78	FrameRxCount2	6	R	0	number of received frames [13:8]

5.4 MAC header registers

Addr.	Register name	bits	type	default	description
8'h82	mhrFc1Tx	8	RW	0	MAC header frame control byte1(low byte) (Tx)
8'h83	mhrFc2Tx	8	RW	0	MAC header frame control byte2(high byte) (Tx)
8'h84	mhrSquNbTx	8	RW	0	MAC header sequence number (Tx)
8'h85	mhrDstPanId1Tx	8	RW	0	MAC header dest. pan identifier byte1(low byte) (Tx)
8'h86	mhrDstPanId2Tx	8	RW	0	MAC header dest. pan identifier byte2(high byte)(Tx)
8'h87	mhrDstAddr16_1Tx	8	RW	0	MAC header dest. 16bit address byte1(low byte) (Tx)
8'h88	mhrDstAddr16_2Tx	8	RW	0	MAC header dest. 16bit address byte2(high byte) (Tx)
8'h89	mhrDstAddr64_1Tx	8	RW	0	MAC header dest. 64bit address byte1(low byte) (Tx)
8'h8A	mhrDstAddr64_2Tx	8	RW	0	MAC header dest. 64bit address byte2 (Tx)
8'h8B	mhrDstAddr64_3Tx	8	RW	0	MAC header dest. 64bit address byte3 (Tx)
8'h8C	mhrDstAddr64_4Tx	8	RW	0	MAC header dest. 64bit address byte4 (Tx)
8'h8D	mhrDstAddr64_5Tx	8	RW	0	MAC header dest. 64bit address byte5 (Tx)
8'h8E	mhrDstAddr64_6Tx	8	RW	0	MAC header dest. 64bit address byte6 (Tx)
8'h8F	mhrDstAddr64_7Tx	8	RW	0	MAC header dest. 64bit address byte7 (Tx)
8'h90	mhrDstAddr64_8Tx	8	RW	0	MAC header dest. 64bit address byte8(high byte) (Tx)
8'h91	mhrSrcPanId1Tx	8	RW	0	MAC header source pan identifier byte 1(low byte) (Tx)
8'h92	mhrSrcPanId2Tx	8	RW	0	MAC header source pan identifier byte 2(high byte) (Tx)
8'h93	mhrSrcAddr16_1Tx	8	RW	0	MAC header source 16bit address byte 1(low byte) (Tx)
8'h94	mhrSrcAddr16_2Tx	8	RW	0	MAC header source 16bit address byte 2 (Tx)
8'h95	mhrSrcAddr64_1Tx	8	RW	0	MAC header source 64bit address byte 1 (Tx)
8'h96	mhrSrcAddr64_2Tx	8	RW	0	MAC header source 64bit address byte 2 (Tx)
8'h97	mhrSrcAddr64_3Tx	8	RW	0	MAC header source 64bit address byte 3 (Tx)
8'h98	mhrSrcAddr64_4Tx	8	RW	0	MAC header source 64bit address byte 4 (Tx)
8'h99	mhrSrcAddr64_5Tx	8	RW	0	MAC header source 64bit address byte 5 (Tx)
8'h9A	mhrSrcAddr64_6Tx	8	RW	0	MAC header source 64bit address byte 6 (Tx)
8'h9B	mhrSrcAddr64_7Tx	8	RW	0	MAC header source 64bit address byte 7 (Tx)
8'h9C	mhrSrcAddr64_8Tx	8	RW	0	MAC header source 64bit address byte 8(high byte) (Tx)

5.5 PHY registers

Addr	register name	bits	Name	Remarks
8'h00	RPCC	8	phyCurrentChannel Register	RF channel selection
8'h05	RTXM	6	Transmitter Mode Register	Transmitter baseband filtering, output port select, and PA output level controls
8'h0E	RAGCL	8	AGC Level Register	Indicates AGC level in closed loop mode and sets AGC gain in open loop mode

The system description in paragraph 8 gives information about the registers in the PHY. Many more registers *can* be accessed and programmed/read but are not essential for typical applications. All PHY registers are written through MAC commands as defined in the IEEE802.15.4 standard. They can be overridden. All PHY registers are read and write capable. Every register can be written to and read from at any time during operation by the microcontroller through either the parallel or SP Interface. A detailed description of all register will be available as an application note.

6 Application circuit – external components

The ZMD44101 requires very few external components allowing for a small module form factor and low Bill of Material costs. Figure 6.3 depicts which components are required in a typical application. Aside from these components only a microcontroller, with it's external components, is needed. This microcontroller has to maintain and control the application specific software dependent functions as defined by the Zigbee™ standard. The standard microcontroller interfaces are described in paragraph 4.3.

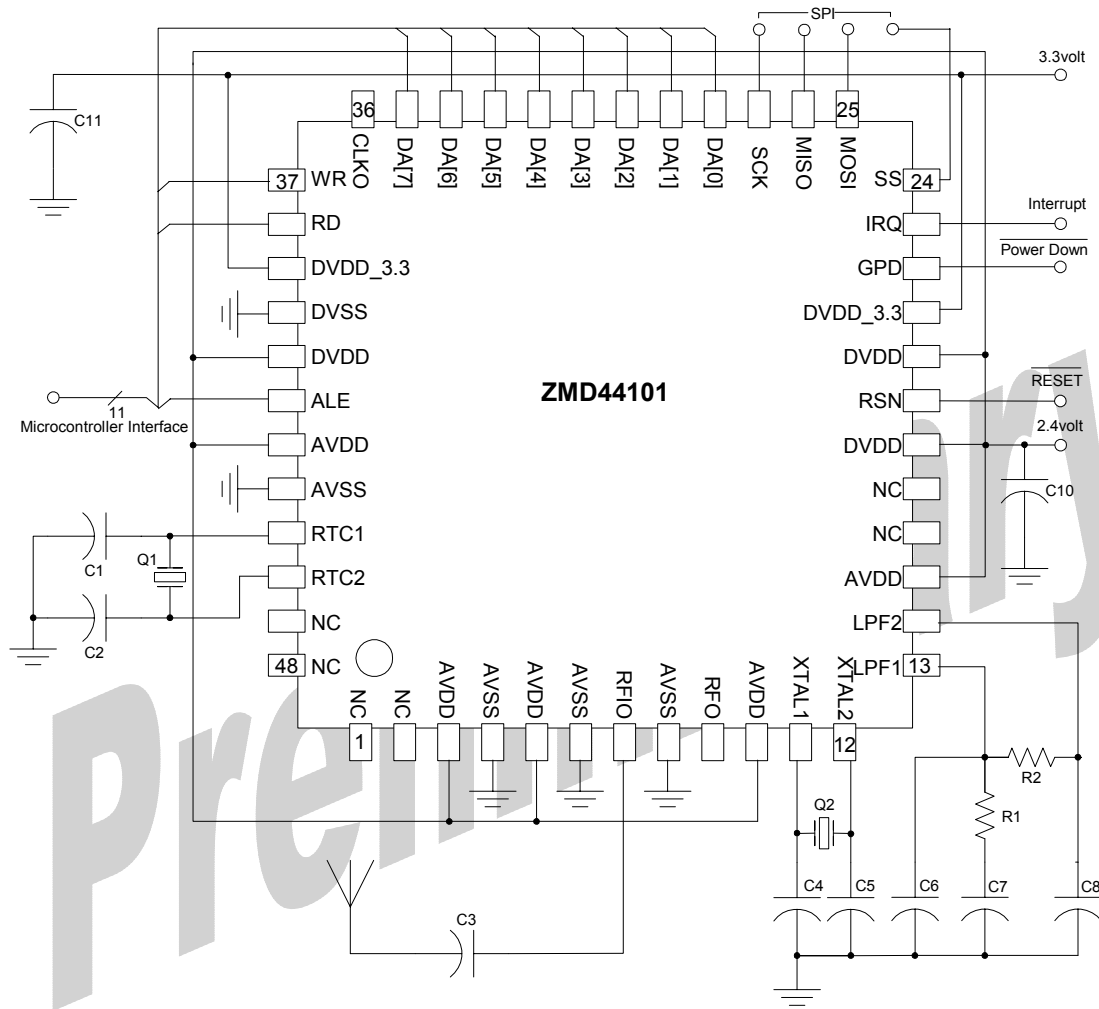

Figure 6.1 - external components in a typical ZMD44101 application

component	value	component	value
C1	15pF, 5%, SMD	C8	15pF, 5%, SMD
C2	15pF, 5%, SMD	C10	>100uF 100nF, 6.3v, decoupling
C3	22pF, 5%, SMD	C11	>100uF 100nF, 6.3v, decoupling
C4	43pF, 5%, SMD	R1	12kOhm, 5%, SMD
C5	43pF, 5%, SMD	R2	3.9kOhm, 5%, SMD
C6	5.6pF, 5%, SMD	Q1	32.768kHz, watch crystal type
C7	220pF, 5%, SMD	Q2	24MHz, ±40ppm

7 ZMD44101 System Performance Summary

Note: Simulated system performance based on IEEE 802.15.4 standard.

Parameter	Value
Operational Specifications	
Supply Voltage	+2.2V to +2.7V (typical +2.4V)
Digital IO Voltage	+3.0V to +3.6V (typical +3.3V)
Temperature Range	-40°C to +85°C
Frequency of Operation	868MHz to 870MHz (EU) and 902MHz to 928MHz (US)
Typical Supply Current (TX)	32mA
Typical Supply Current (RX-synchronization)	31mA
Typical Supply Current (RX-normal)	28mA
Typical Supply Current (sleep mode)	2µA
System Specifications	
Standard Basis	IEEE 802.15.4/D18 Compliant
Spreading Technique	Direct Sequence Spread Spectrum (DSSS)
Modulation Type	Binary Phase Shift Keying (BPSK)
Data Rate Burst	20kBits/s (EU) and 40kBits/s (US)
PN Code	15-chip m-sequence
Processing Gain	12dB
Chip Rate	300kBit/s (EU) and 600kBit/s (US)
RF Bandwidth	600kHz (EU) and 1200kHz (US)
RF Channel Spacing	2MHz (IEEE 802.15.4 compliant)
Overall Crystal Accuracy	±40ppm
Architecture	
Receiver (RX)	Direct Down-Conversion
Transmitter (TX)	Direct Up-Conversion
Phase Locked Loop (PLL)	Sigma-Delta Fractional-N
Block Specifications	
RF_PLL Frequency Resolution	732Hz
TX Output Power	0dBm (to 50Ω)
TX Spurious Emissions	ETSI (EN 300 220) and FCC (Part 15) compliant
RX Sensitivity	-100dBm@PER<1%
RX Maximum Usable Input Level	-20dBm
RX Selectivity/Blocking Performance	IEEE 802.15.4 Compliant + ETSI RX Class 2
General Parameters	
Package	48-pin QFN (=MLF™ MicroLeadFrame)
ESD Protection	>2kV (Human Body Model – HBM)
Interface	SPI and Parallel
External Components	24MHz & 32.768kHz XTAL, PLL loop filter (RC), Antenna, Microcontroller
Process Technology	0.25µm CMOS

8 System Description

8.1 General Block Diagram

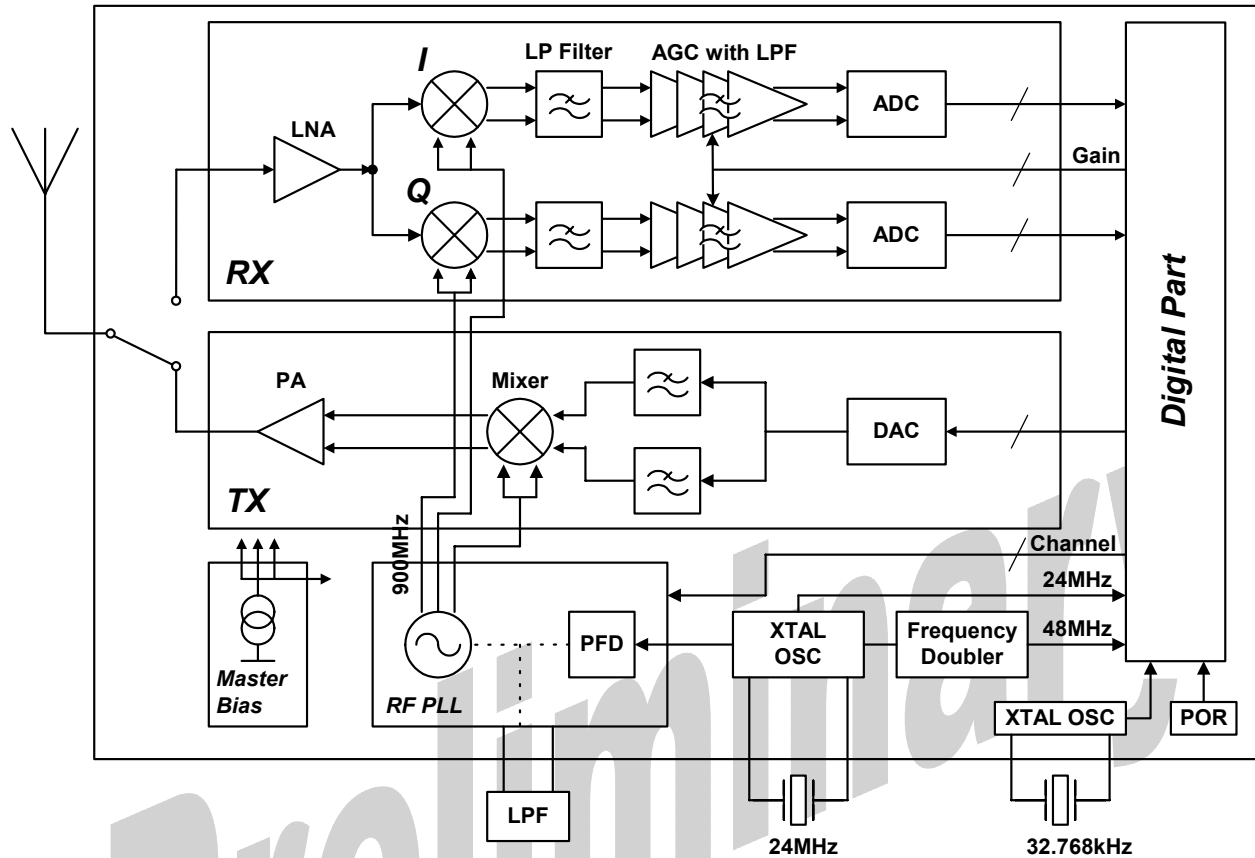

Figure 8.1 - Integrated Analog PHY Layer block diagram

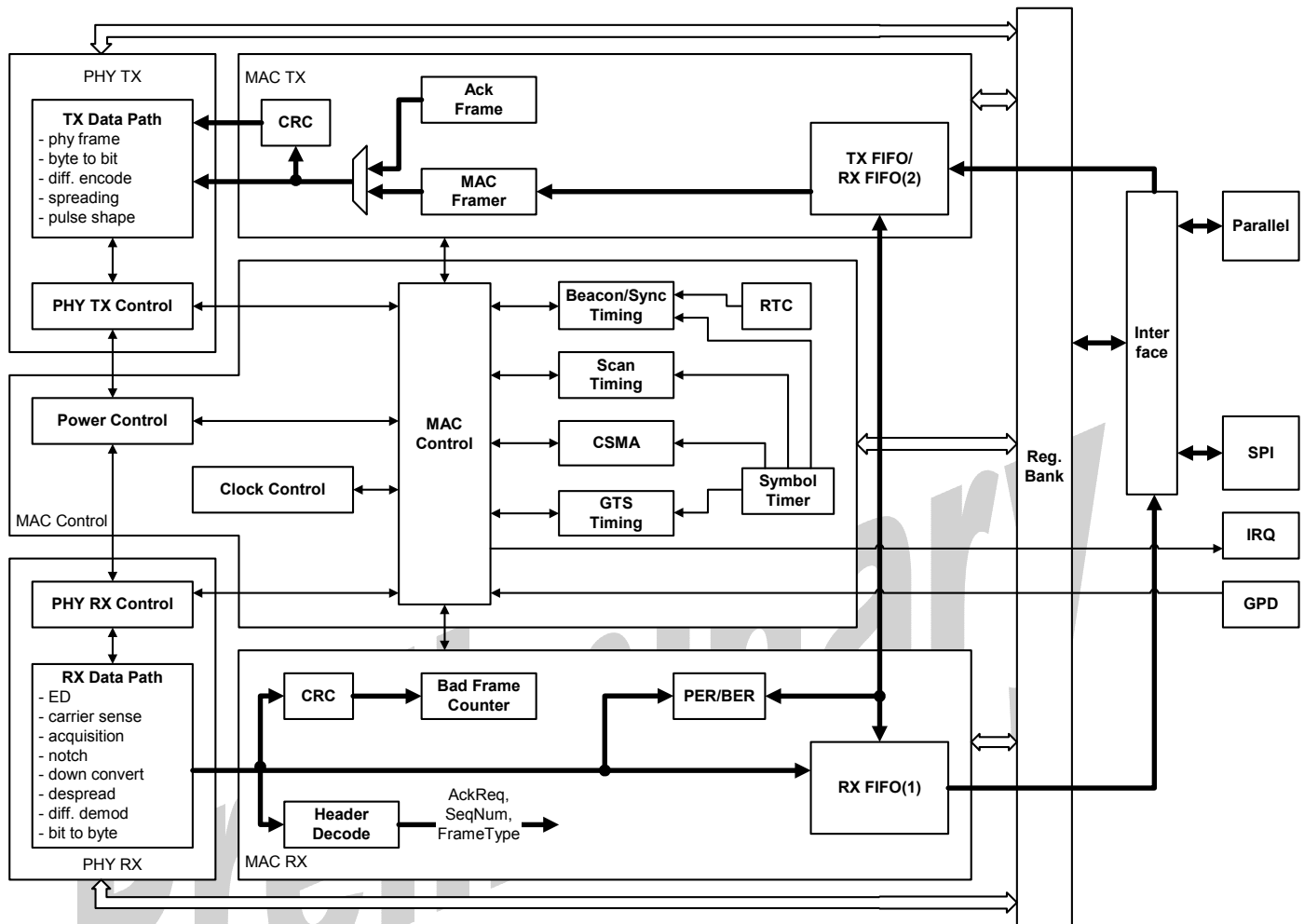

Figure 8.2 - Integrated digital PHY and MAC Layer block diagram

8.2 Receiver Chain

The receiver of the ZMD44101 uses a direct-conversion architecture (Zero-IF architecture).

The receiver path consists of a 900MHz low-noise amplifier (LNA) and a mixer, followed by the analog baseband. It contains multi-stage programmable gain amplifiers, low-pass filter sections and Analog-to-digital converters (ADC). All remaining functions are carried out in the digital domain including synchronization, de-spreading and demodulation as well as the AGC loop control. To extend the dynamic range further, the LNA and mixer gain can be adjusted in the AGC loop.

In normal operation mode, the user or the MAC starts the reception using the default register values. All control signals (timing, power-down) are set automatically.

One receiver register setting can be important for receiver operation (RAGCL). This is described in paragraph 8.2.1. Besides this register there are registers which are used in both, transmit and receive mode.

8.2.1 RAGCL - AGC Level Register

Bit7	Bit6	Bit5	Bit4	Bit3	Bit2	Bit1	Bit0
0	1	1	1	1	1	1	1

1=gain high, 0=gain low

The register *can* be used to read the AGC level back to the microcontroller at any time during receiver operation. This way information about the signal strength *can* be derived by the microcontroller. The high gain default value (hex7F) together with the digital peak detection function ensures fast settling time by reducing the gain in steps to a usable signal level for the digital signal processing inside the ZMD44101.

8.3 Transmitter Chain

A direct-conversion architecture is used for the transmitter of the ZMD44101. The design is fully differential. Only the Power Amplifier (PA) output is single-ended. No external balun is required.

In normal operation mode, the user or the MAC starts the transmission using the default register values. All control signals (timing, power-down) are set automatically.

Optionally two default register settings of the transmitter can be changed by writing to the *Transmitter Mode Register (RTXM)*. By default, the PA drives 0dBm (1mW) to a 50 Ohm off-chip load. This output power can be changed between 0dBm and -21dBm.

8.3.1 RTXM - Transmitter Mode Register

	Bit7	Bit6	Bit5	Bit4	Bit3	Bit2	Bit1	Bit0
default	0	0	0	0	0	0	0	0
0 dBm output power	0	0	0	0	X	X	X	X
-7 dBm output power	0	0	0	1	X	X	X	X
-14 dBm output power	0	0	1	0	X	X	X	X
-21 dBm output power	0	0	1	1	X	X	X	X
Normal operation	0	0	X	X	X	0	0	0
Carrier only modulation	0	0	X	X	X	0	1	0
Constant '0' data transmit	0	0	X	X	X	1	0	0
RFIO is output	0	0	X	X	0	X	X	X
RFO is output	0	0	X	X	1	X	X	X

TX-RX-Switch Configuration

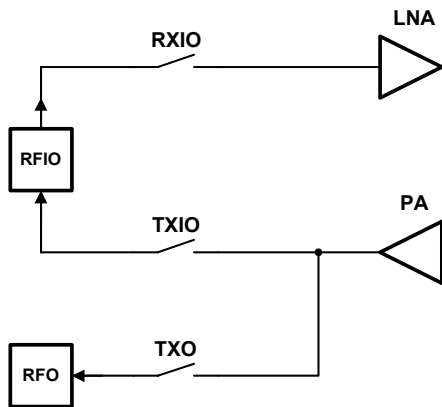

Furthermore, by default the receiver input and the transmitter output use the same pin (*RFIO*). The integrated antenna switch disconnects the respective components in transmit and receive mode.

By changing bit3 in the *RTXM* register, the transmitter uses *RFO* as the output pin. This allows to use an external Power Amplifier for higher output power and extended range (see left figure).

The antenna has to be connected via an external 22pF capacitor.

8.4 RF Phase Locked Loop

A fractional-N Phase Locked Loop (PLL) architecture is used. All functions are integrated on chip except for the loop filter. The external loop filter circuitry is depicted in Figure 8.3. The 24MHz crystal (see paragraph 8.5) provides the reference frequency for both the EU- and US-bands.

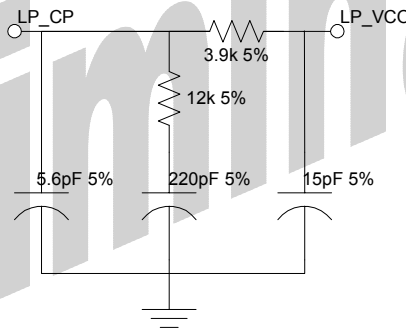

Figure 8.3 - PLL-Loop filter

In normal operation mode, the user sets the frequency channel of the RF PLL prior to transmission or reception. All control signals (timing, power-down) are set automatically by writing to the phyCurrentChannel register (RPCC), but can be overwritten for non-standard applications. The data rate (EU: 20kBit/s and US: 40kBit/s) is adjusted automatically according to the selected channel. The channel numbers are defined by the IEEE 802.15.4 standard. Figure 8.4 illustrates the channel allocation in the 900MHz band. Table 8.1 depicts the RPCC programming in the ZMD44101.

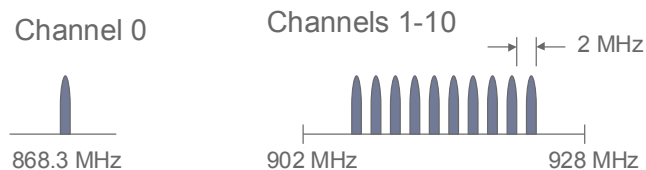

Figure 8.4 - Channel allocation in the 900MHz band

Band	Channel select (RPCC Reg.) as per IEEE802.15.4	Channel (MHz)	Channel (bin) (RPLC1/2 Reg.)	Channel (dec)	SEL_SUBBAND (RPLM Reg.)
European	0	868.3	0010110111011101	11741	01
USA	1	906	1100000000000001	49153	10
USA	2	908	1101010101010101	54613	10
USA	3	910	1110101010101011	60075	10
USA	4	912	0000000000000000	0	11
USA	5	914	0001010101010101	5461	11
USA	6	916	0010101010101011	10923	11
USA	7	918	0100000000000001	16385	11
USA	8	920	0101010101010101	21845	11
USA	9	922	0110101010101011	27307	11
USA	10	924	1000000000000001	32769	11

Table 8.1 – Channel select register programming according to the IEEE 802.15.4 standard

8.5 Reference Crystal Oscillator (24MHz)

A two (2) pin Pierce oscillator with on-chip biasing resistor is designed to provide the necessary reference frequency at 24MHz. This frequency is used for digital clock supply, timing calculations as well as for the PLL that generates the RF carrier frequency. For the receive modes the internal circuitry doubles the reference frequency in order to achieve the digital processing speed during code acquisition. This oscillator is only active in Idle, Transmit and Receive power modes.

The user can also provide an external 24MHz clock reference on XTAL1. This external clock has to have 24MHz at a duty cycle of 1:1 and an accuracy of ± 40 ppm. Provided this case no 24MHz crystal is required between XTAL1 and XTAL2 and XTAL2 is not connected.

When the internal oscillator is used C4 and C5 are required as load capacitors for the parallel resonance crystal. The values C4 and C5 are different for any specific environment. The overall load capacitance is composed of the actual values of C4 and C5 as well as the parasitic values of the PCB layout and the internal parasitic capacitance of the ZMD44101, which is 0.65pF on each pin. The total load capacitance has to match the recommended typical load capacitance provided by the crystal manufacturer. For a recommended 97SMX240 22B crystal (SMI) the load capacitance is 22pF \pm 0.5%. Any deviation on this system part will result in large deviation on the carrier frequency and output spectrum.

This clock is available for external use on Pin 36, CLKO. It can be used to support a microcontroller. During power-down and sleep mode the microcontroller clock is switched to 32.768kHz or to selectable fractions of 32.768kHz for reduced current consumption. This ensures the microcontroller has a clock signal during power-down and therefore can correctly wake up from the power-down state. During all other states the 24Mhz clock or selectable fractions of 24MHz can be used on CLKO.

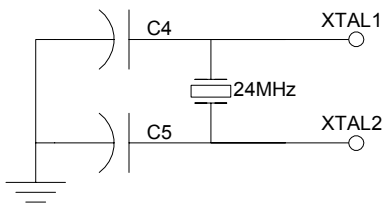

Figure 8.5 - 24Mhz crystal oscillator – external components

8.6 Low Power Crystal Oscillator (32.768kHz)

The 32.768kHz crystal oscillator is designed for extreme low power operation as it always runs when power is applied to the device. The oscillator provides the time reference for the on-chip real time clock. The oscillator utilizes an amplitude controlled two (2) pin Pierce oscillator with on-chip biasing resistor. The same as described for the 24MHz oscillator in paragraph 8.5 is valid for the load capacitance.

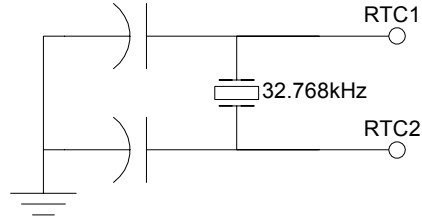

Figure 8.6 - 32.768khz crystal oscillator – external components

This clock is available for external use on Pin 36, CLKO. It can be used to support a microcontroller. During power-down and sleep mode the microcontroller clock is switched to 32.768kHz or to selectable fractions of 32.768kHz for reduced current consumption. This ensures the microcontroller has a clock signal during power-down and therefore can correctly wake up from the power-down state.

8.7 CLKO - Clock Output Configuration

This register is part of the MAC control and status registers. The clock on the CLKO pin can be configured according to the following table for external microcontroller clock support. Pin36 can directly drive a clock input up to 4mA.

value	ClkOutConfig[7:6]	ClkOutConfig[5:4]	ClkOutConfig[3:2]	ClkOutConfig[1:0]
	RtcDiv(M)	Clk24Div(N)	NormalModeClk	SleepModeClk
0	1	1	OFF	OFF
1	2	2	32k/M	32k/M
2	4	4	24M/N	24M/N
3	8	8		

The table is to be read as follows. Example default: The ClkOutConfig(@default)=8'b00101001, compares to "0,2,2,1". That means: M=1, N=4, during normal mode (everything but not sleep or GPD) CLKO is 24MHz/4=6MHz, and during sleep mode CLKO is 32.768kHz.

8.8 Power Management

The ZMD44101 has five different modes of power management. These modes are user configurable and controlled by the external microcontroller. The power modes are as follows:

- **Tx/Rx:** Tx or Rx is active.
- **IDLE:** Tx/Rx are powered down but the 24MHz crystal oscillator remains on.
- **SLEEP:** All circuits are switched off except the 32.768kHz RTC for accurate time reference. Power consumption is reduced to 2 μ A (typical).
- **POWER DOWN:** The ZMD44101 enters into power down by setting the Global Power Down (GPD) function.
- **POWER OFF:** The supply voltage is switched off externally. The ZMD44101 has a Power On Reset (POR) function.

NOTE: The ZMD44101 contains internal master bias circuitry. No adjustments or external circuitry are required for accurate operation.

Preliminary

9 Mechanical Specifications

9.1 Package

48pin QFN Package

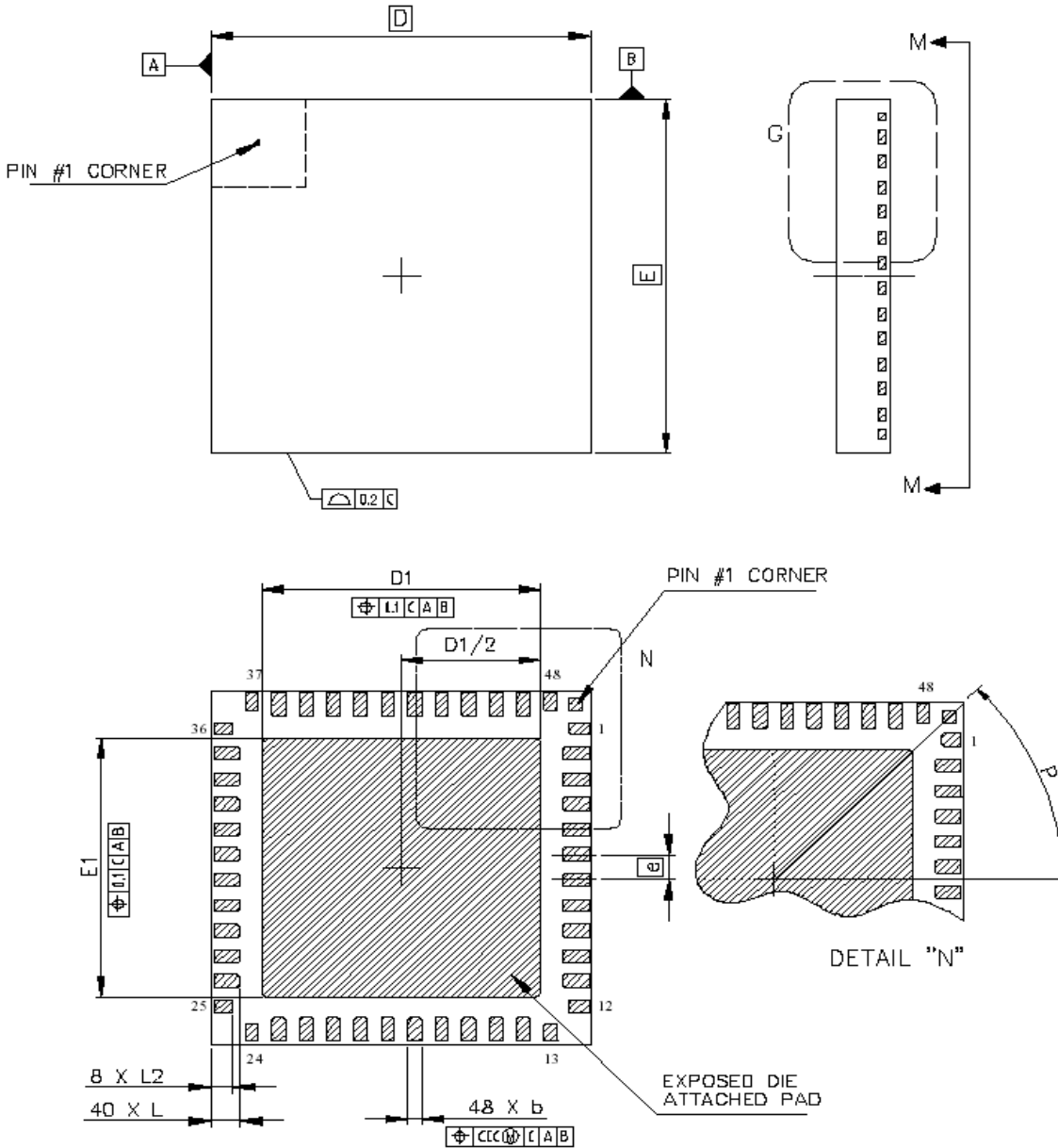

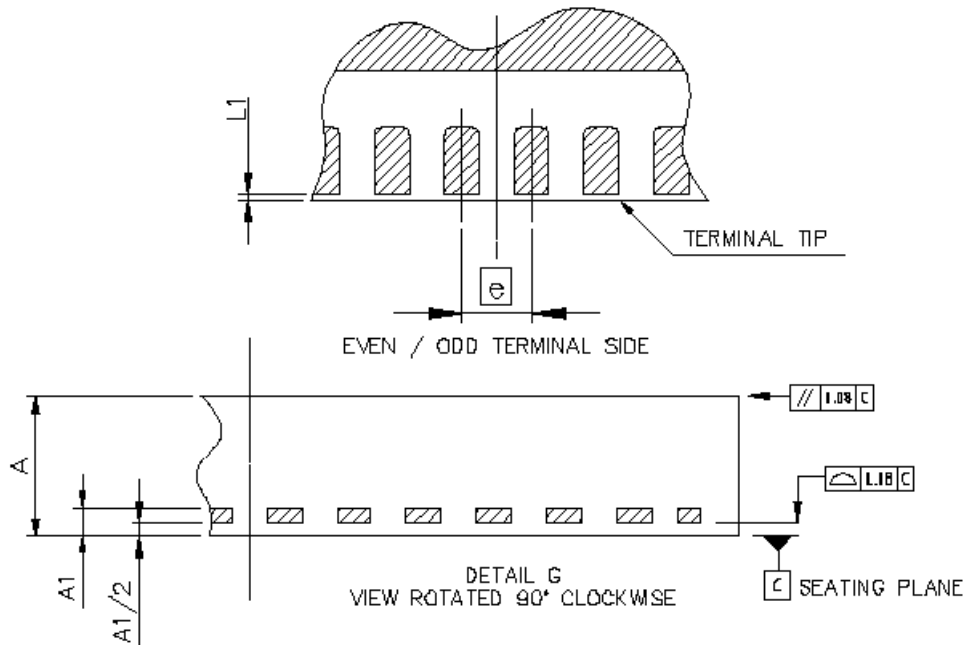

Dim	Min	Typ	Max	Notes
A	0.80		1.00	
A1		0.203 Ref		
b	0.18	0.25	0.30	Applies to metallized terminal and is measured between 0.25mm and 0.30mm from terminal tip.
D	7.00 BSC			
E	7.00 BSC			
D1	5.04		5.24	
E1	5.04		5.24	
e	0.50 BSC			
L	0.43	0.53	0.63	
L1			0.10	Represents terminal full back from package edge up to 0.1mm is acceptable.
L2	0.30	0.40	0.50	
P	45° BSC			
aaa	0.15			
ccc	0.10			

Notes:

1. Dimensions and tolerances conform to ASME Y14.5M-1994
2. All dimensions are in millimeters. Angles are in degrees.
3. Co-planarity applies to the exposed head slug as well as the terminal.
4. Radius in terminal is optional.

10 List of abbreviations

ADC	Analog-to-Digital Converter	IRQ	Interrupt request
AES	Advanced Encryption Standard	ISM	Industrial- Scientific Medical
AGC	Automatic Gain Control	kbit/s	Kilobit per second
BER	Bit Error Rate	kHz	Kilohertz
BPSK	Binary Phase Shift Keying	LNA	Low Noise Amplifier
CMOS	Complementary Metal Oxide Silicon	LoS	Line of sight
		LP Filter	Low Pass Filter
CRC	Code Redundancy Check	MAC	Medium Access Controller
CSMA	Carrier Sense Multiple Access	MISO	Master-In-Slave-Out,
DAC	Digital-to-Analog Converter	MOSI	Master-Out-Slave-In
dB	Decibel	MHz	Megahertz
DSSS	Direct Sequence Spread Spectrum	MLF	Micro Lead Frame
		PER	Packet Error Rate
ED	Energy Detection	PHY	Physical (Layer)
ESD	Electrostatic Discharge	PLL	Phase Locked Loop
ETSI	European Telecommunications Standards Institute	QFN	Quad Flat Pack
		RF	Radio Frequency
EU	Europe	RTC	Real Time Clock
FCC	Federal Communications Commission	RX	Receiver
		SPI	Serial Peripheral Interface
FIFO	First In First Out	SS	Slave-Select (refers to CS=Chip Select)
GPD	General Power Down		
GTS	Guaranteed Time Slot	TX	Transmitter
IEEE	Institute of Electrical and Electronics Engineers	US	United States
		XTAL	Crystal
IF	Intermediate Frequency		

11 References

- IEEE 802.15.4-2003 Standard: "IEEE Standard for Part 15.4: Wireless Medium Access Control (MAC) and Physical Layer (PHY) Specifications for Low Rate Wireless Personal Area Networks (LR-WPANs)". Download: <http://standards.ieee.org/getieee802/download/802.15.4-2003.pdf>
- ETSI EN 300 220-1 V1.3.1 (2000-09)
- FCC Part 15, December 18 2001

The information furnished here by ZMD is believed to be correct and accurate as of the publication date. However, ZMD shall not be liable to any third party for any damages, including but not limited to personal injury, property damage, loss of profits, loss of use, interruption of business or indirect, special, incidental, or consequential damages of any kind in connection with or arising out of the furnishing, performance, or use of the technical data. No obligation or liability to any third party shall arise or flow out of ZMD's rendering technical or other services.

**For
Further
Information****ZMD**

Phone: 858-674-8433
Fax: 858-674-8071
e-mail: wireless@zmda.com

ZMD

15373 Innovation Drive
Suite 115
San Diego, CA 92128
<http://www.zmd.biz>

ZMD AG

Grenzstrasse 28
D-01109 Dresden
Tel.: +49 351 8822 928
Fax: +49 351 8822 666

Products sold by ZMD are covered exclusively by the ZMD standard warranty, patent indemnification, and other provisions appearing in ZMD standard "Terms of Sale". Testing and other quality control techniques are used to the extent ZMD deems necessary to support this warranty. Except where mandated by government requirements, testing of all parameters of each product is not necessarily performed. ZMD makes no warranty (express, statutory, implied and/or by description), including without limitation any warranties of merchantability and/or fitness for a particular purpose, regarding the information set forth in the Materials pertaining to ZMD products, or regarding the freedom of any products described in the Materials from patent and/or other infringement.

ZMD reserves the right to discontinue production and change specifications and prices, make corrections, modifications, enhancements, improvements and other changes of its products and services at any time without notice. ZMD products are intended for use in commercial applications. Applications requiring extended temperature range, unusual environmental requirements, or high reliability applications, such as military, medical life-support or life-sustaining equipment, are specifically not recommended without additional mutually agreed upon processing by ZMD for such applications. ZMD assumes no liability for application assistance or customer product design. Customers are responsible for their products and applications using ZMD components.

Print date: 30.03.2005 11:29

Preliminary