

MS-213-3



MS-213-3

Miniature Reed Sensor

Electrical Characteristics @ 25 °C

Contact form		A
Contact rating max.	W / VA	10
Switching voltage max.	VDC	180
	VAC	130
Switching current max.	A	0.7
Carry current max.	A	1
Breakdown voltage min.	VDC	200
Total resistance max. (initial)	mΩ	300
Insulation resistance min.	Ω	10 ⁹

Features

- > Compact size
- > Mechanically protected
- > Replaces various competitors types
- > Various sensitivity ranges available

Magnetical Characteristics (of unmodified Reed Switch) @ 25 °C

Pull in range available	AT	10 - 25
Drop out min.	AT	4
Test coil	TC	010
Test equipment tolerance	± AT	2

Approvals



Operating Characteristics (of unmodified Reed Switch) @ 25 °C

Switching frequency max.	Hz	500
Resonant frequency typ.	Hz	5000
Operate time max. (incl. bounce)	ms	0.5
Release time max.	ms	0.3

Environmental Characteristics

Operating temperature	°C	-20 to +85
Vibration (50-2000 Hz)	g	20
Shock (1/2 sin 11 ms)	g	100

Dimensions in mm

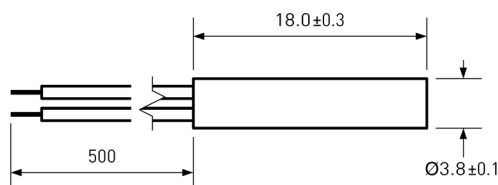

Ordering Information

Packing Unit	50 pcs
Weight per piece	2.3 g
Weight per package	127 g
Standard AT Ranges	
	1 = 10 to 15 AT
	2 = 15 to 20 AT
	3 = 20 to 25 AT

Ordering Example

MS-213-3-2 describes MS-213-3 with 15 to 20 AT.

MS-213-3



MS-213-3
Miniature Reed Sensor

Material Information

	Material	Colour
Housing	ABS	black
Cable	UL 1061, AWG 26, 4 mm stripped and tinned	black
Potting compound	Epoxy	black

Test Procedure of final Reed Sensor

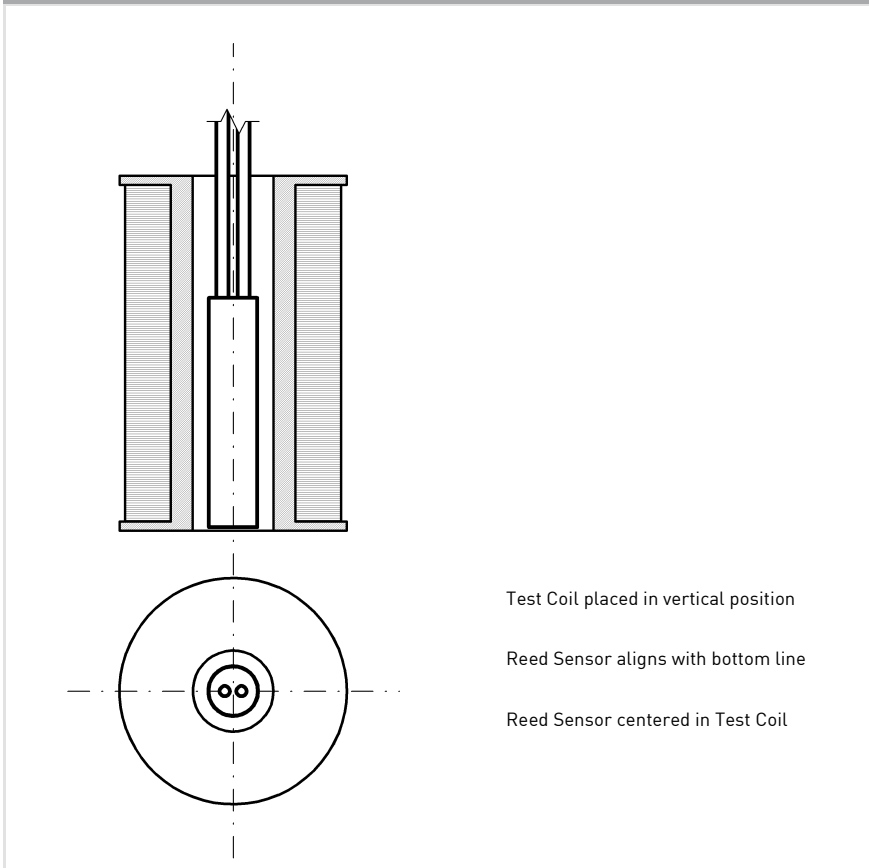

Test Parameters

Test coil	TC-093
Test programs	
AT range	Test program
1 =	MS-213-3-1
2 =	MS-213-3-2
3 =	MS-213-3-3

Remarks

When mounted onto ferromagnetic parts switching distance of MS-213-3 may reduce.
Electromagnetical influences and magnetic fields may change the switching behaviour of the sensor.